

Constellation  
Heritage  
4700 Models  
4800 Models

4900 Models  
> 5700 Models  
5900 Models  
6900 Models

Western Star  
Service Bulletin

**Description of Revisions:** *This bulletin replaces the version dated 09/18/2019. The part number for the oil control valve has been updated in the parts table.*

## General Information

An air-to-oil transmission oil cooler is available for vehicles equipped with a DT12 transmission.

It can be added to the vehicle even if it was not originally equipped with a transmission oil cooler or it can replace a water-to-oil transmission oil cooler located in the bottom tank of the radiator.

The retrofit process involves adding the new cooler to the radiator support frame, updating/adding a new oil cooler control valve in the transmission, and updating/adding cooler plumbing lines.

Parts that are required for the retrofit include:

- Air-to-oil transmission oil cooler
- Transmission oil cooler plumbing
- 90-degree JIC line fittings
- Transmission oil cooler ports (in transmission)
- Transmission oil control valve (in transmission)
- Hardware
- Transmission Oil-to-Air Cooler Update Kit DSN012T18001

Refer to the Parts Tables at the end of this bulletin to determine which parts are required to retrofit the transmission cooler. See the detailed BOM information in [Table 4](#) to determine which part list is compatible with the vehicle.

## Work Instructions

### Transmission Oil to Air Cooler Installation

1. Park the vehicle on a level surface, shut down the engine, and set the parking brake. Chock the tires.
2. Remove the bumper.
3. Inspect the radiator frame for cooler mounting holes. See [Fig. 1](#). If the radiator frame has cooler mounting holes and there are no obstructions on your vehicle, it may not be necessary to remove the hood to install the cooler.

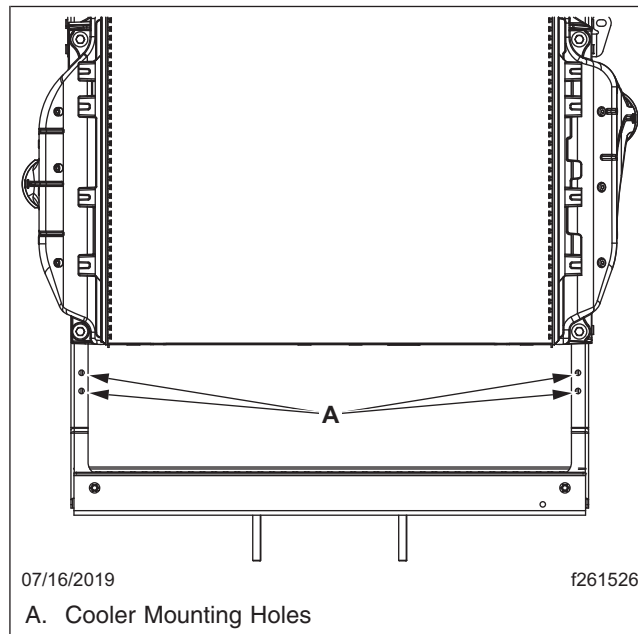

**Fig. 1, Radiator Frame With Cooler Mounting Holes**

4. If necessary, remove the hood.
5. Remove the lower radiator baffle.
6. Remove the side baffles.
  - 6.1 If the radiator frame already has cooler mounting holes, the baffles do not need to be removed. Proceed with step 7.
  - 6.2 If the vehicle has a multi-baffle system, remove the bottom fasteners that hold the left- and right-side baffles in place. If not, proceed with step 6.3.
  - 6.3 If the vehicle has a one-piece baffle, remove all the fasteners and adjust it to clear the area at the bottom of the frame.
7. If the vehicle was originally equipped with a transmission cooler to the radiator, remove the jumper lines from the radiator.
8. If the radiator frame already has cooler mounting holes, and there are no nuts welded to the back surface of the flange, install the U-nuts (23-12625-010). Continue with step 13, cutting a pass-through on the lower air baffle.
9. If the radiator frame needs cooler mounting holes, use the drilling-location template tool (07-24621-000) to mark the radiator frame for new oil cooler mounting bolts as follows:
  - 9.1 Position the template tool on the bottom left corner of the radiator frame as shown in **Fig. 2**. Mark the two drilling locations on the left front of the radiator frame.

Constellation  
Heritage  
4700 Models  
4800 Models

4900 Models  
> 5700 Models  
5900 Models  
6900 Models

Western Star  
Service Bulletin

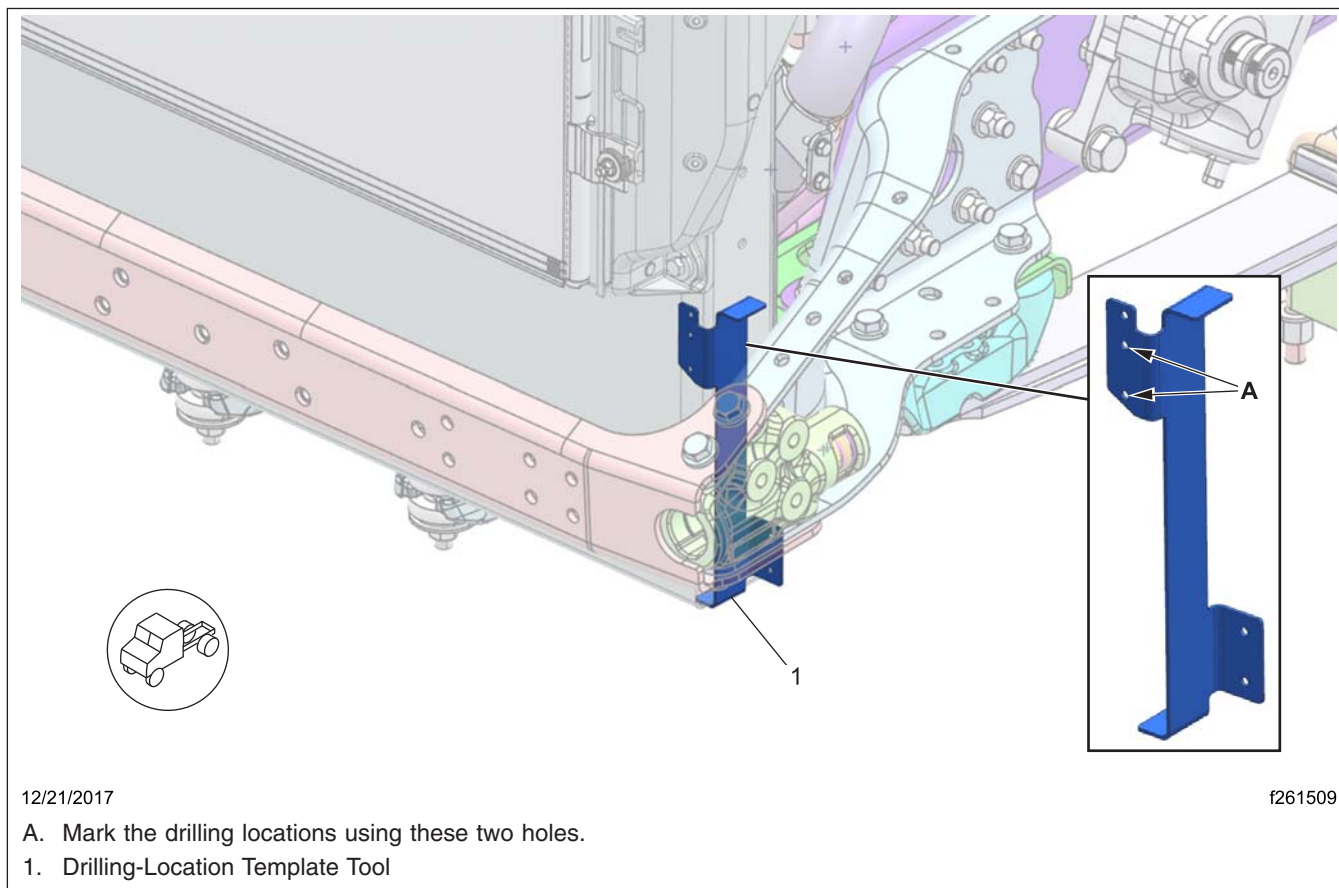

**Fig. 2, Drilling Locations on the Left Front of the Radiator Frame**

- 9.2 Position the template tool on the bottom right corner of the radiator frame as shown in **Fig. 3**. Mark the two drilling locations on the right front of the radiator frame.

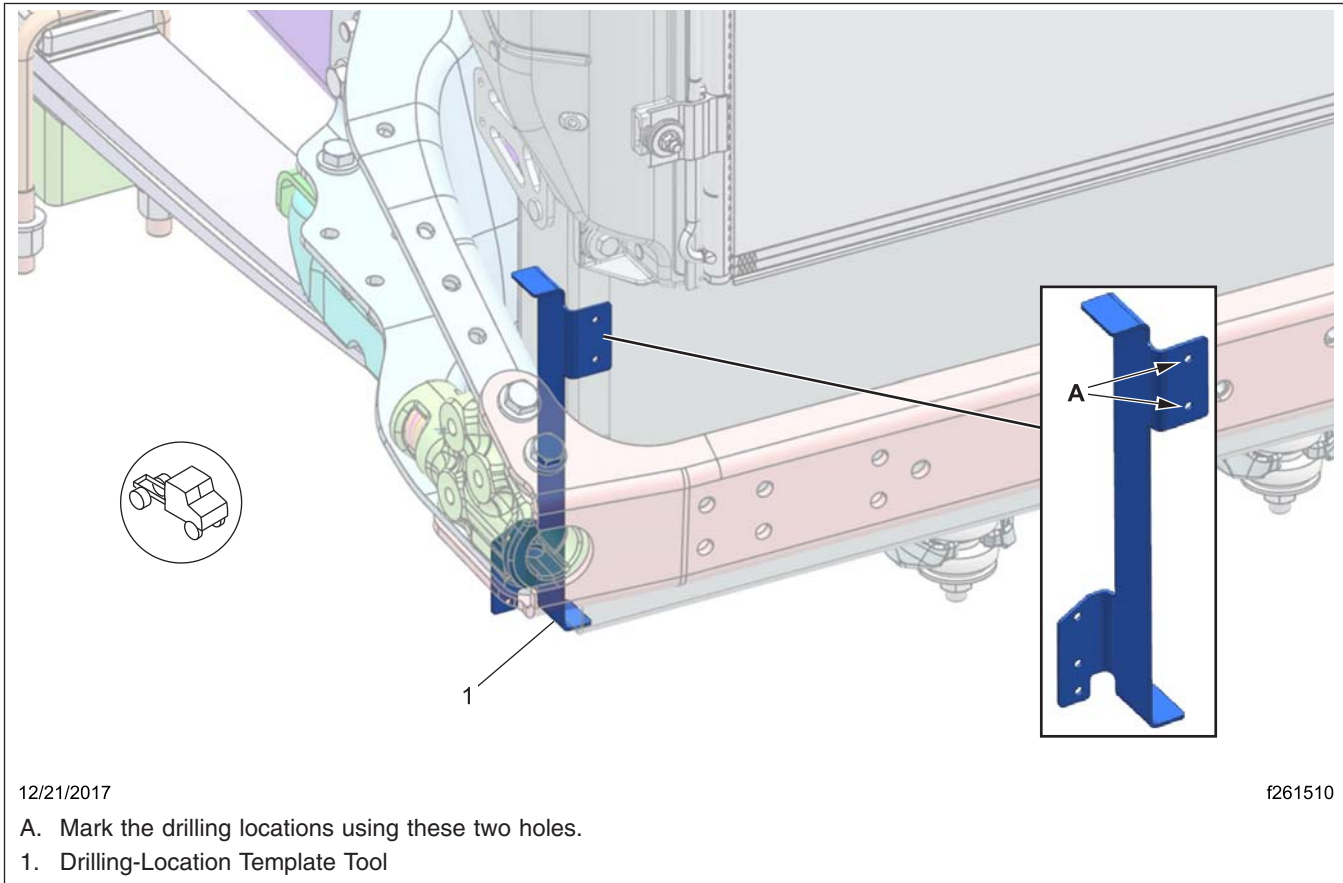

**Fig. 3, Drilling Locations on the Right Front of the Radiator Frame**

10. Remove the cooler bushings and test fit the cooler to confirm the locations of the holes are correct.
11. Center-punch the new bolt locations.

**NOTE:** The radiator frame is very close to the radiator core, which can be easily damaged by a drill. Insert a drill backing plate to prevent the drill from breaking through the support channel and damaging the radiator.

12. Using the standard-length drill bit from the tool kit, drill and tap the holes in the radiator frame for the transmission cooler, as follows:
  - 12.1 Set the drill-stop depth so that only 1/2 in (13 mm) of the drill bit protrudes from the stop sleeve. See [Fig. 4](#).

Constellation  
Heritage  
4700 Models  
4800 Models

4900 Models  
> 5700 Models  
5900 Models  
6900 Models

Western Star  
Service Bulletin

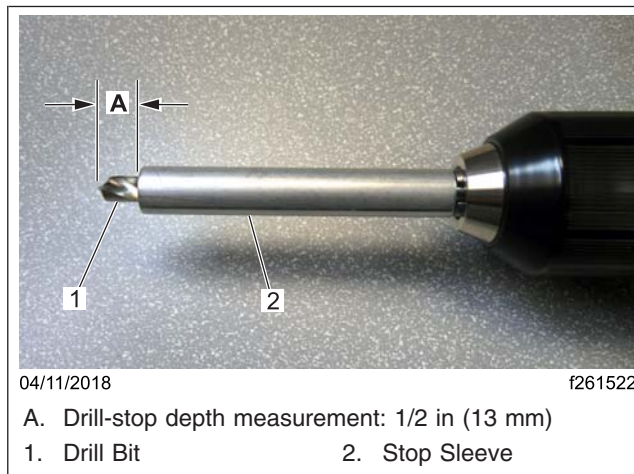
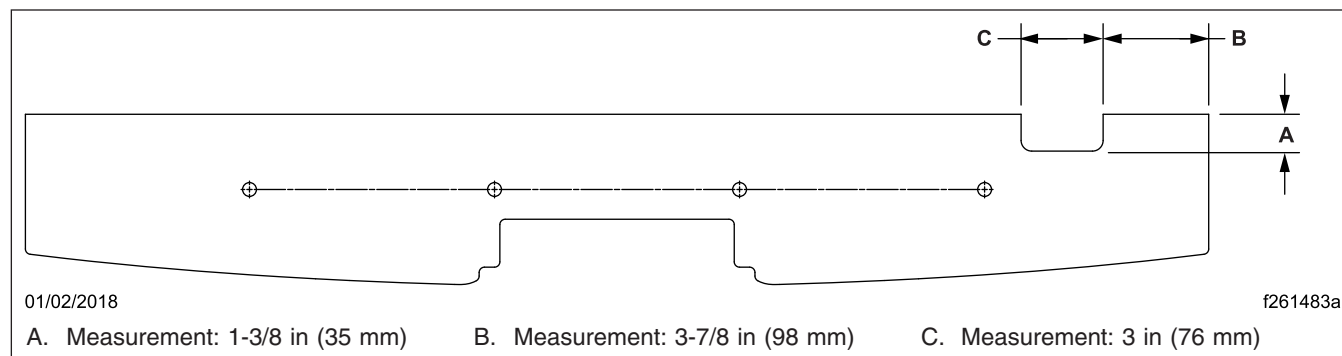

**Fig. 4, Setting the Drill-Stop Depth**

12.2 Drill the holes.

12.3 Tap the holes to 8 mm x 1.25 metric threads.

13. Mark and cut a pass-through on the lower air baffle. See [Fig. 5](#) for locating the cutout.



**Fig. 5, Lower Air Baffle Cutout**

14. Turn the bushing liners so the flange is facing the radiator frame and install the bushings. See [Fig.6](#).

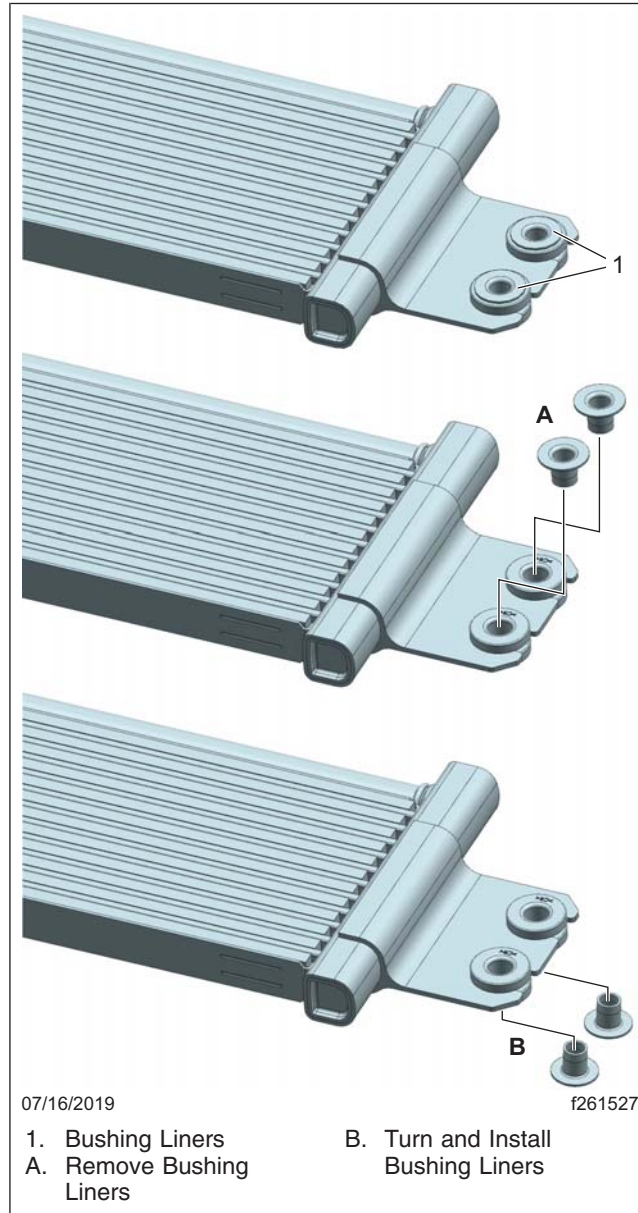

**Fig. 6, Turn & Install Bushing Liners**

15. Install the cooler. Apply medium strength thread locker on the fasteners then tighten the fasteners 7 lbf-ft (9.5 N·m).
16. Install the jumper-line support bracket.
  - 16.1 If the radiator frame already has a drilled hole for the jumper-line support bracket, install the threaded rivet (23-12631-381) in the radiator frame. See [Fig. 7](#). Proceed to step 20, fitting the jumper tube assembly.

Constellation  
Heritage  
4700 Models  
4800 Models

4900 Models  
> 5700 Models  
5900 Models  
6900 Models

Western Star  
Service Bulletin

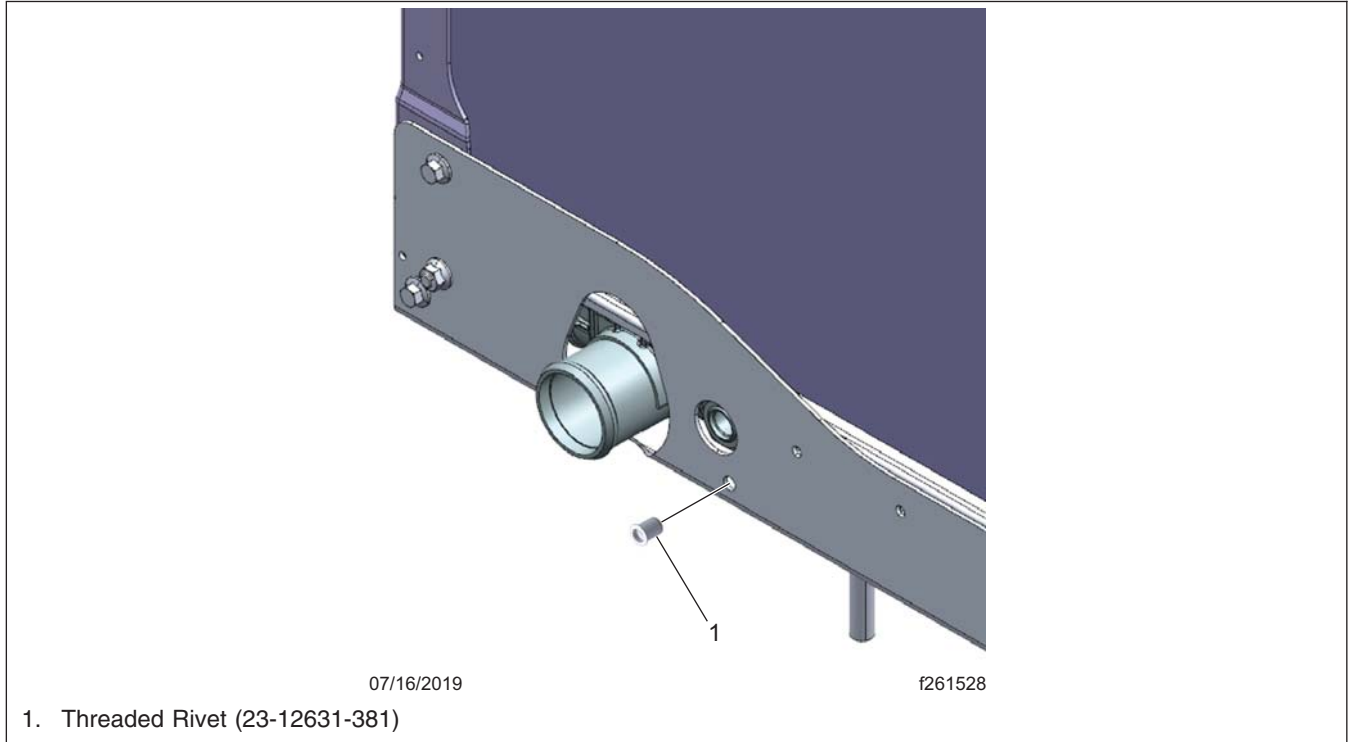

**Fig. 7, Threaded Rivet for Jumper-Line Support Bracket**

- 16.2 If the radiator frame does not have a hole for the jumper-line support bracket, position the template tool (07-24621-000) on the bottom left corner of the radiator frame, and mark the drilling location on the back of the radiator frame for the jumper-line support bracket hole, as shown in [Fig. 8](#).

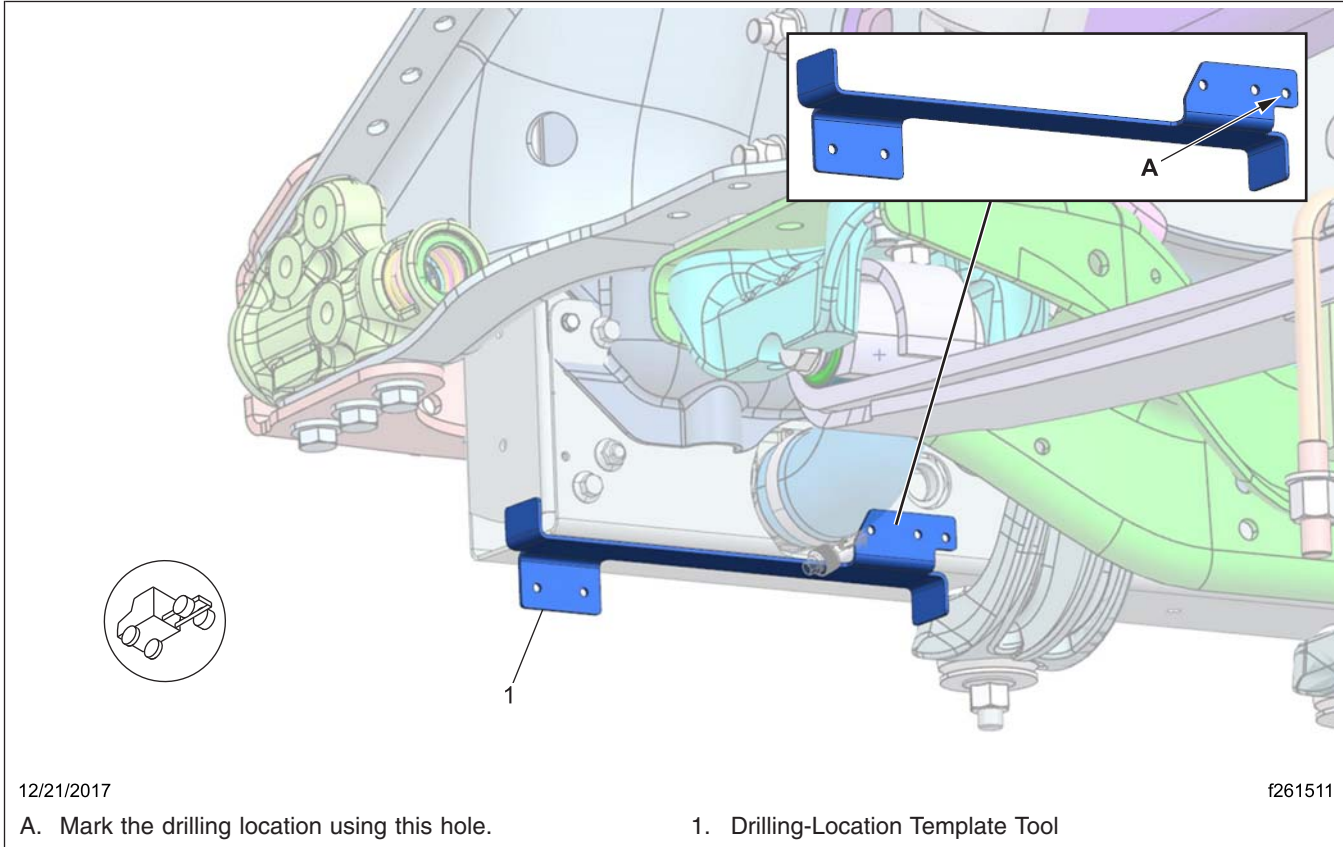

**Fig. 8, Drilling Location on the Back of the Radiator Frame**

17. Test fit the jumper tubes and the line clamp bracket to confirm the location of the hole is correct. Once confirmed, remove the jumper tube/bracket assembly.

18. Use a center punch to mark the drilling location.

**NOTE:** As long as the drill is kept parallel with the bottom of the lower radiator support channel, the lower radiator tank is above the drilling location. Use care to prevent damage to the lower radiator tank.

19. Using the short drill bit from the tool kit, drill the hole in the back of the radiator frame, then tap the hole to 8 mm x 1.25 metric threads.

**NOTE:** If the radiator frame was pre-drilled, and the riv-nut was installed, do not apply thread locker to the jumper-tube support-bracket fastener.

20. Fit the jumper-tube assembly to the cooler, the jumper cushion-clamp, and the support bracket, then apply medium-strength thread locker to the jumper-tube support-bracket fastener. Confirm the tube assembly is not in a bind from the support clamp.

21. Tighten the clamp-support-bracket-to-radiator fastener 11 lbf·ft (15 N·m).

22. Tighten the jumper-tube-to-oil-cooler fasteners 14 to 16 lbf·ft (19 to 22 N·m).

23. Tighten the jumper-line cushion-clamp screw 11 lbf·ft (15 N·m).

Constellation  
Heritage  
4700 Models  
4800 Models

4900 Models  
> 5700 Models  
5900 Models  
6900 Models

Western Star  
Service Bulletin

24. Install the side and lower radiator baffles.

## Transmission Update

NOTE: The oil cooler control valve for air-to-oil is different than the control valve for water-to-oil and so must be replaced if the transmission was originally equipped with a water-to-oil cooler.

1. Drain the transmission oil.
2. Install a new seal ring on the drain plug, then install the drain plug and tighten it 45 lbf-ft (60 N·m).

Note: Make sure the seal rings from the cooler port plugs don't stick to the transmission housing, preventing the face of the adapter from sealing to the transmission.

3. If the vehicle was originally not equipped with a transmission cooler, remove the cooler port plugs in the transmission. Install the JIC fittings, and tighten them 56 lbf-ft (76 N·m).
4. Remove the pump cover from the back of the transmission See [Fig. 9](#).



**Fig. 9, Transmission Pump Cover**

5. Remove the original control valve if replacing a water to oil cooler. See [Fig. 10](#).



**Fig. 10, Original Control Valve**

6. Clean the sealant from the transmission housing and the pump cover.
7. If the oil pump drive shaft, hub, and rotor come out during the cover removal, install the oil pump and drive shaft (**Fig. 11**) in the transmission housing. Confirm the dots on the hub and rotor are visible after the pump elements are installed.



**Fig. 11, Oil Pump and Drive Shaft**

8. Clean the bore for the oil control valve. This helps the O-ring retain the spring pressure while the cover is being installed.
9. Apply sealant to the pump cover. See **Fig. 12**.

Constellation  
Heritage  
4700 Models  
4800 Models

4900 Models  
> 5700 Models  
5900 Models  
6900 Models

Western Star  
Service Bulletin

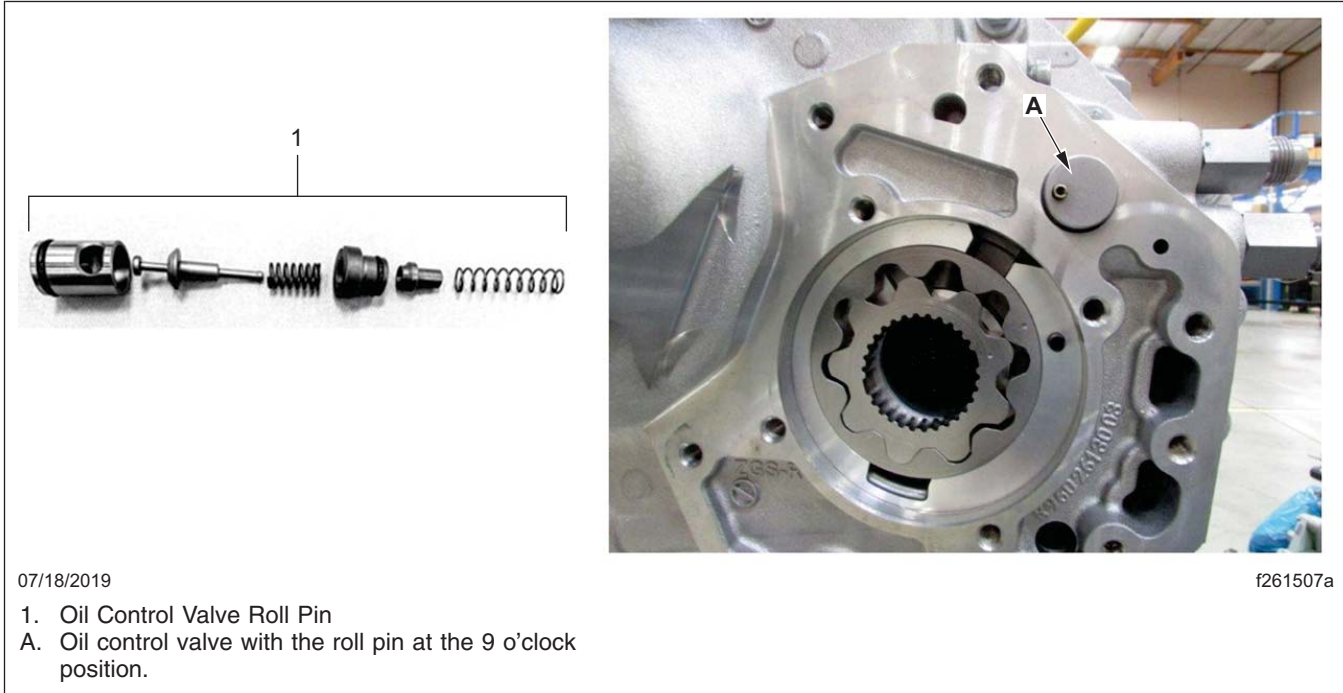

Fig. 12, Sealant Applied to Pump Cover

## **WARNING**

The oil control valve is spring-loaded and will only stay in place due to the drag from the O-ring for a short period of time. Be ready to install the cover once the valve is in place as it can dislodge from the port and spring-launch small parts across the shop floor.

10. Install the oil control valve with the roll pin at the 9 o'clock position. See [Fig. 13](#).



**Fig. 13, Installing New Control Valve**

11. Install the pump cover (**Fig. 14**) and tighten the capscrews 37 lbf-ft (50 N·m).

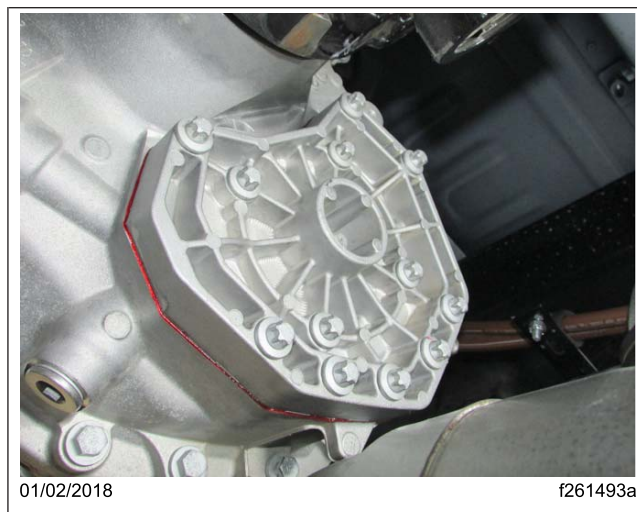

**Fig. 14, Pump Cover Installed**

12. Remove the transmission fill plug and fill the transmission with Detroit Synthetic Transmission fluid, approximately 4.25 gal (16 L).

13. Install the fill plug, using a new seal ring, and tighten it 45 lbf-ft (60 N·m).

Constellation  
Heritage  
4700 Models  
4800 Models

4900 Models  
> 5700 Models  
5900 Models  
6900 Models

Western Star  
Service Bulletin

## Line Installation

1. If the vehicle was previously equipped with an oil cooler located in the bottom tank of the radiator, remove the lines and decommission the in-tank cooler by allowing the oil to drain out and capping the ports in the radiator.
2. Fit the new cooler lines, according to the install diagram (**Fig.15**).

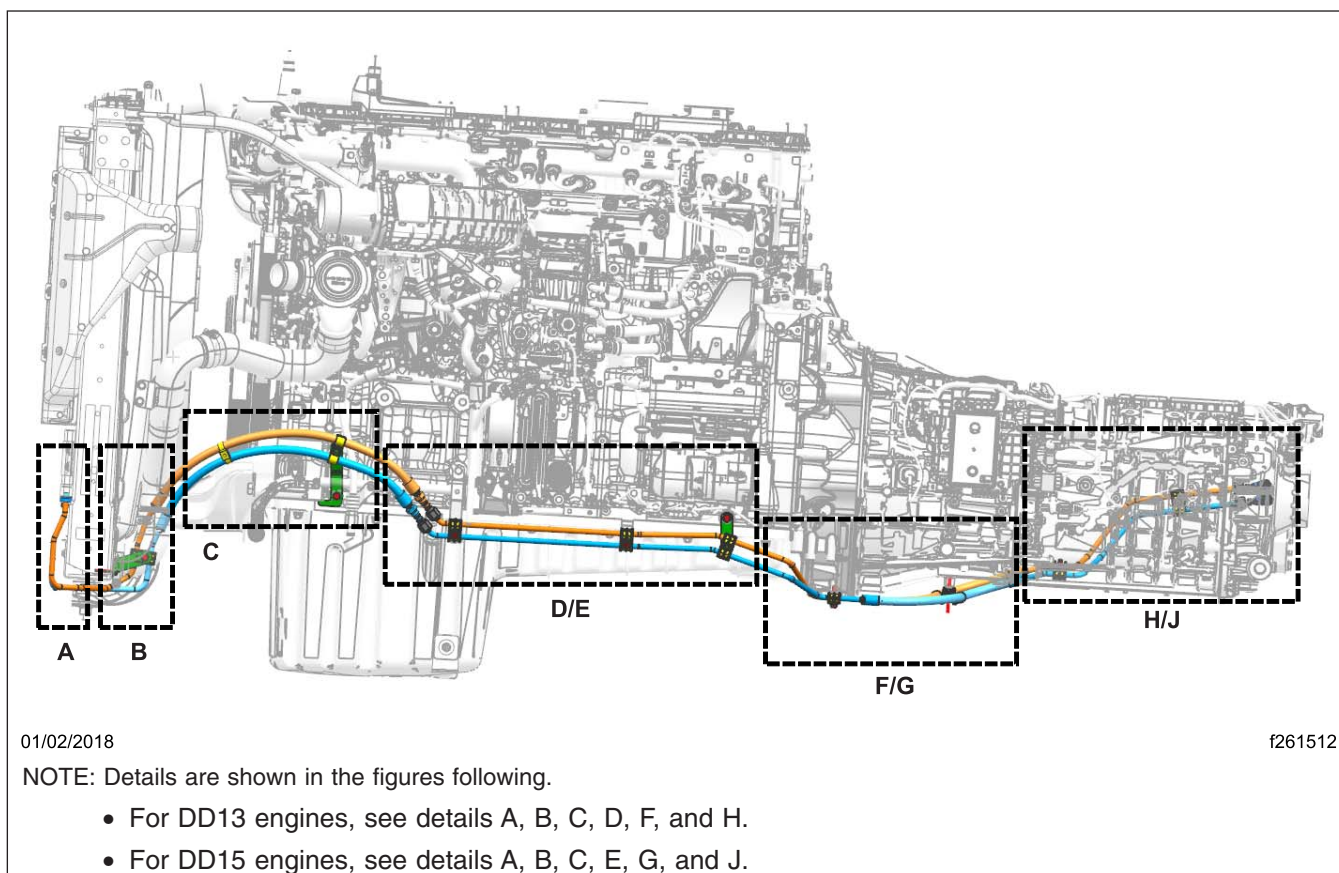

**Fig. 15, New Cooler Line Install**

# 26-004

## DT12 Transmission Cooler Retrofit

Western Star  
Service Bulletin

Constellation  
Heritage  
4700 Models  
4800 Models

4900 Models  
> 5700 Models  
5900 Models  
6900 Models

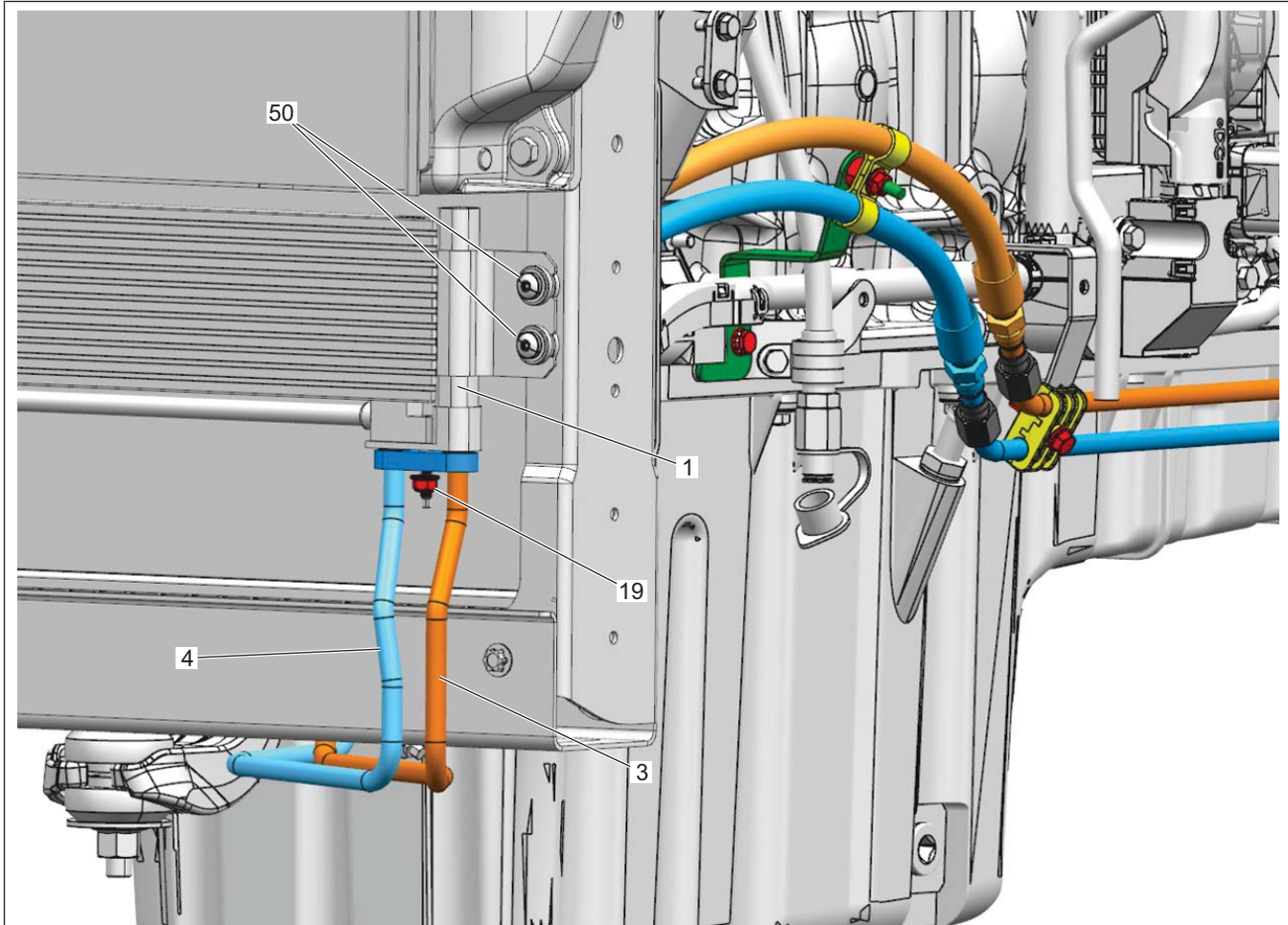

07/09/2019

f261513

NOTE: For parts other than what is listed below, the reference numbers correspond to the parts tables.

1. Transmission Cooler

Fig. 16, Detail A (DD13 and DD15)

Constellation  
Heritage  
4700 Models  
4800 Models

4900 Models  
> 5700 Models  
5900 Models  
6900 Models

Western Star  
Service Bulletin

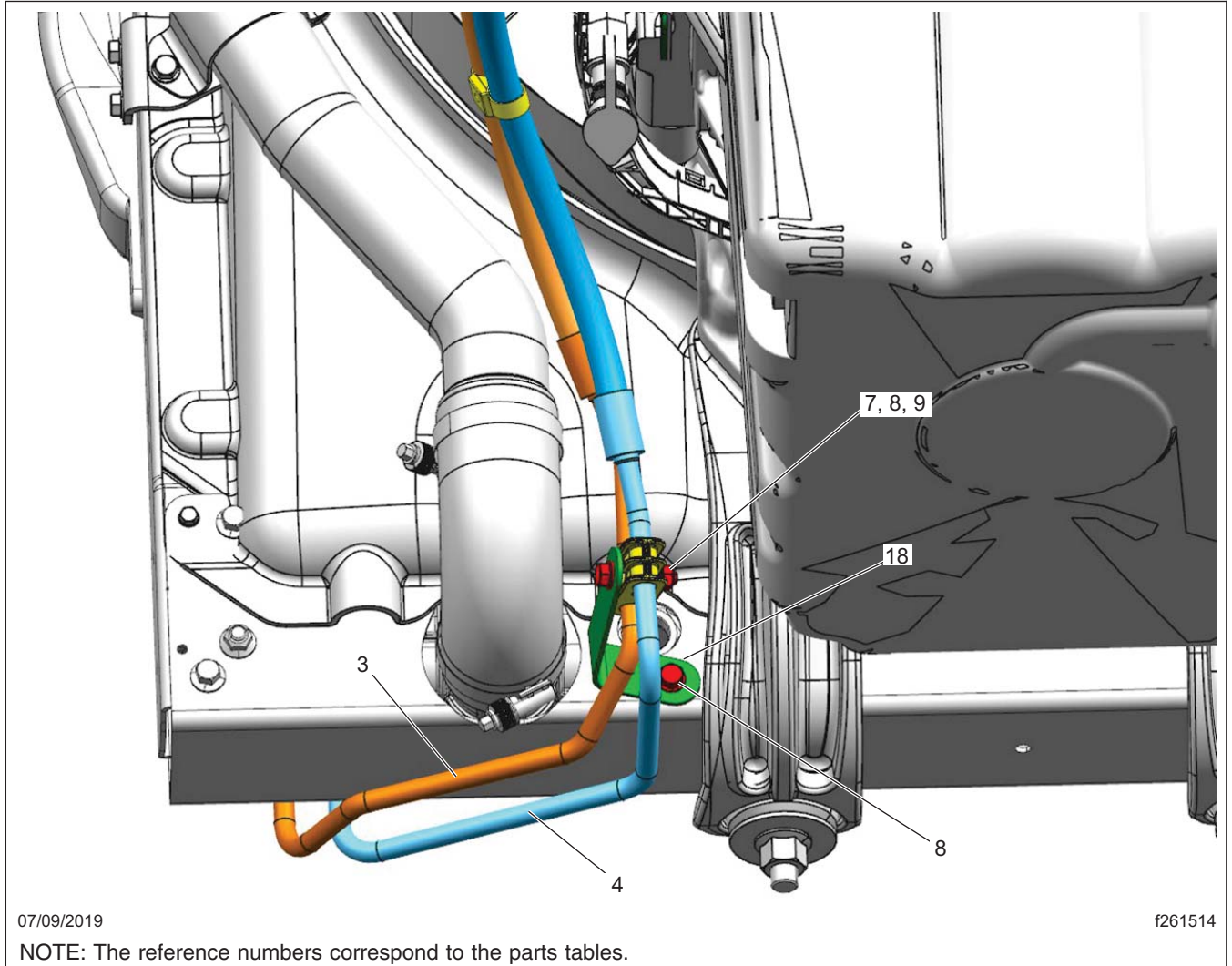

Fig. 17, Detail B (DD13 and DD15)

# 26-004

## DT12 Transmission Cooler Retrofit

Western Star  
Service Bulletin

Constellation  
Heritage  
4700 Models  
4800 Models

4900 Models  
> 5700 Models  
5900 Models  
6900 Models

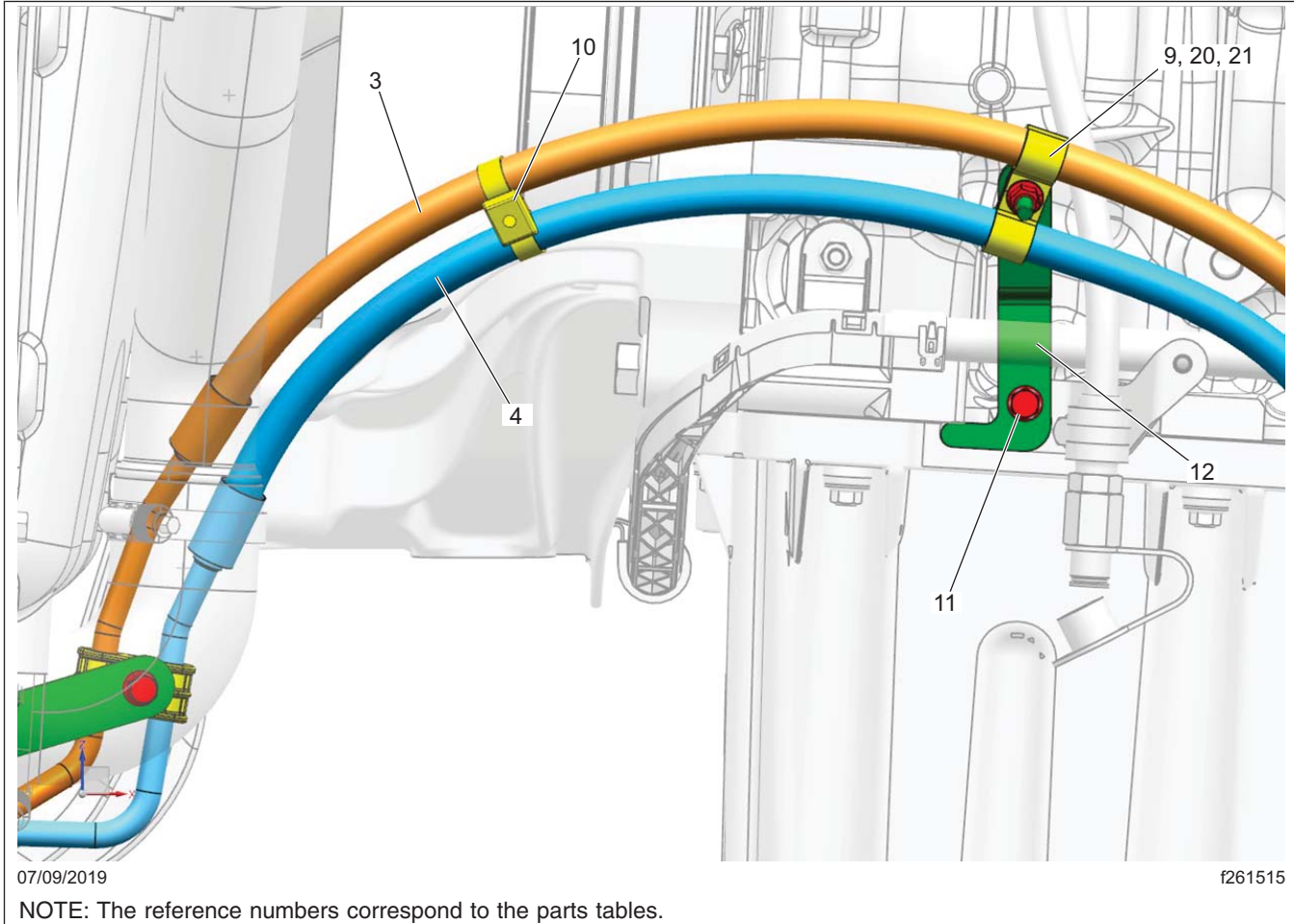

07/09/2019

f261515

NOTE: The reference numbers correspond to the parts tables.

Fig. 18, Detail C (DD13 and DD15)

Constellation  
Heritage  
4700 Models  
4800 Models

4900 Models  
> 5700 Models  
5900 Models  
6900 Models

Western Star  
Service Bulletin

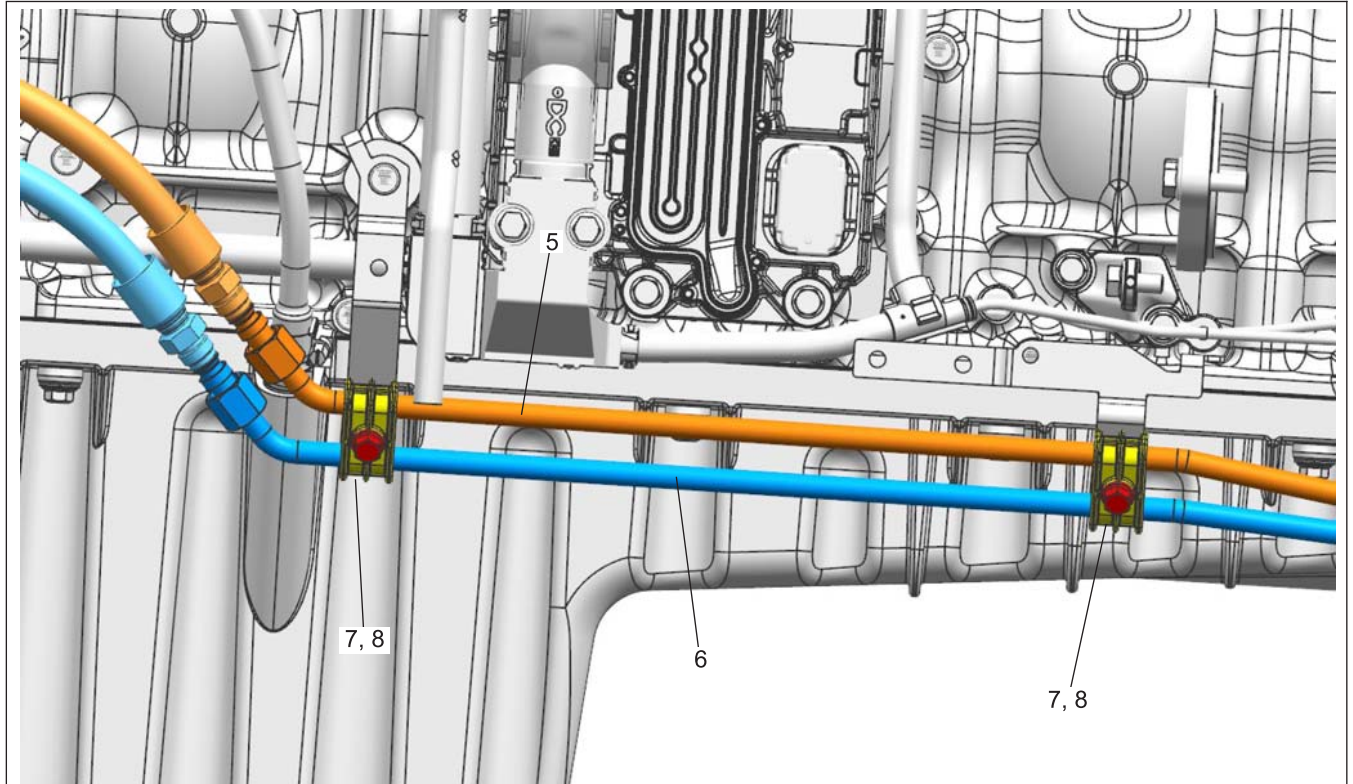

01/02/2018

f261516

NOTE: The reference numbers correspond to the parts tables.

**Fig. 19, Detail D (DD13)**

# 26-004

## DT12 Transmission Cooler Retrofit

Western Star  
Service Bulletin

Constellation  
Heritage  
4700 Models  
4800 Models

4900 Models  
> 5700 Models  
5900 Models  
6900 Models

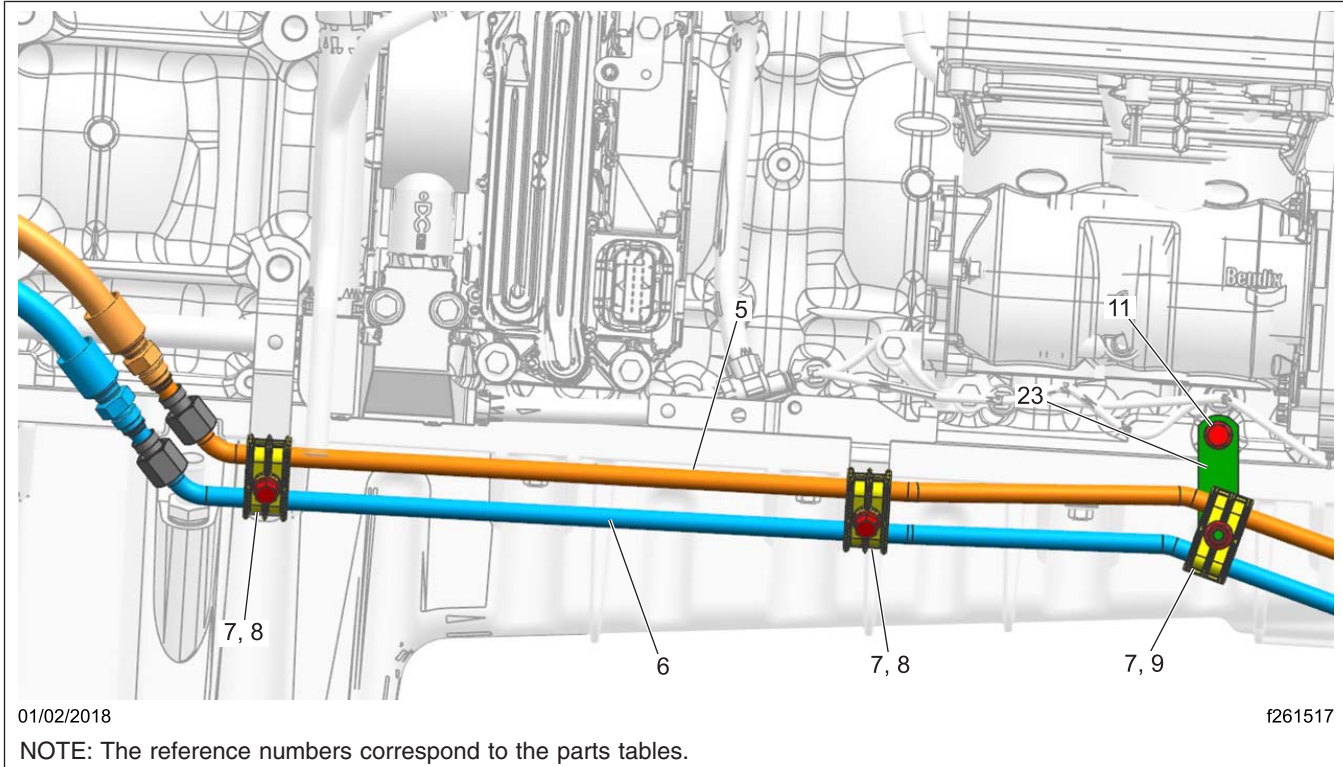
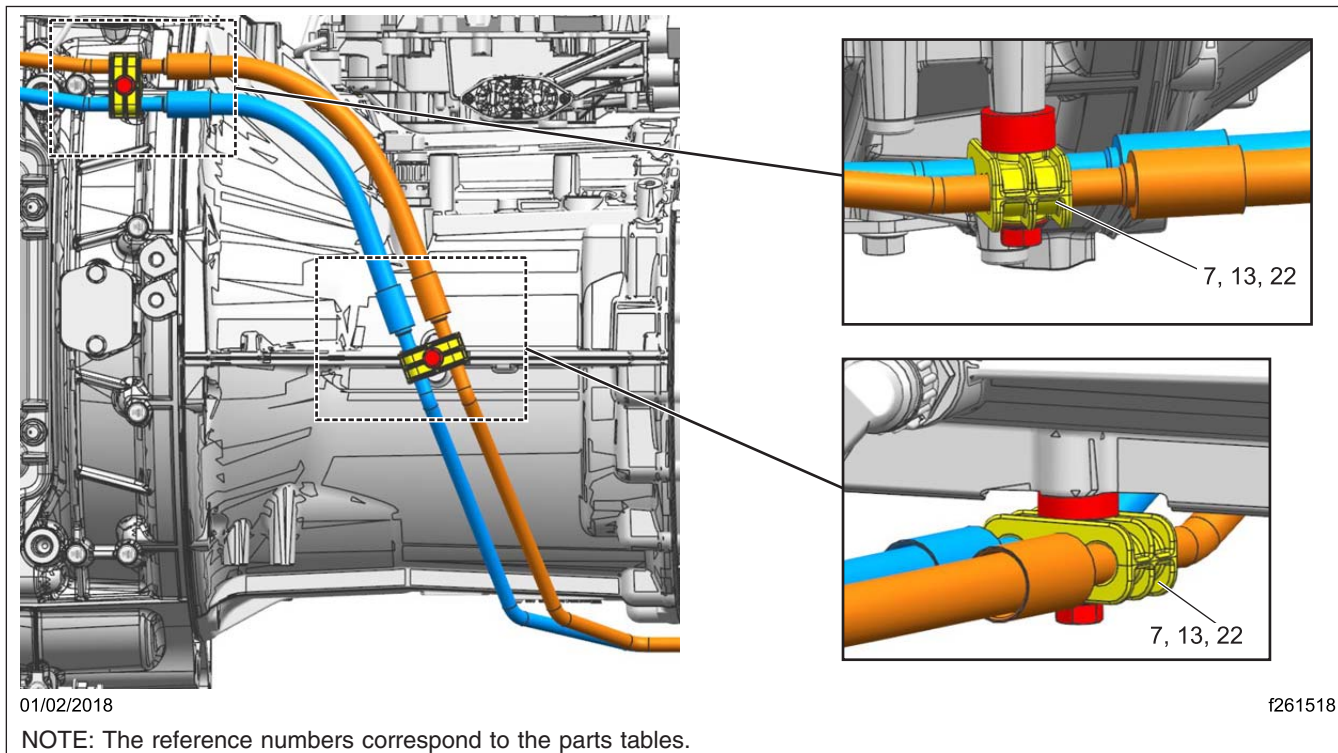

Fig. 20, Detail E (DD15)

Constellation  
Heritage  
4700 Models  
4800 Models

4900 Models  
> 5700 Models  
5900 Models  
6900 Models

## Western Star Service Bulletin



**Fig. 21, Detail F (DD13)**

# 26-004

## DT12 Transmission Cooler Retrofit

Western Star  
Service Bulletin

Constellation  
Heritage  
4700 Models  
4800 Models

4900 Models  
> 5700 Models  
5900 Models  
6900 Models

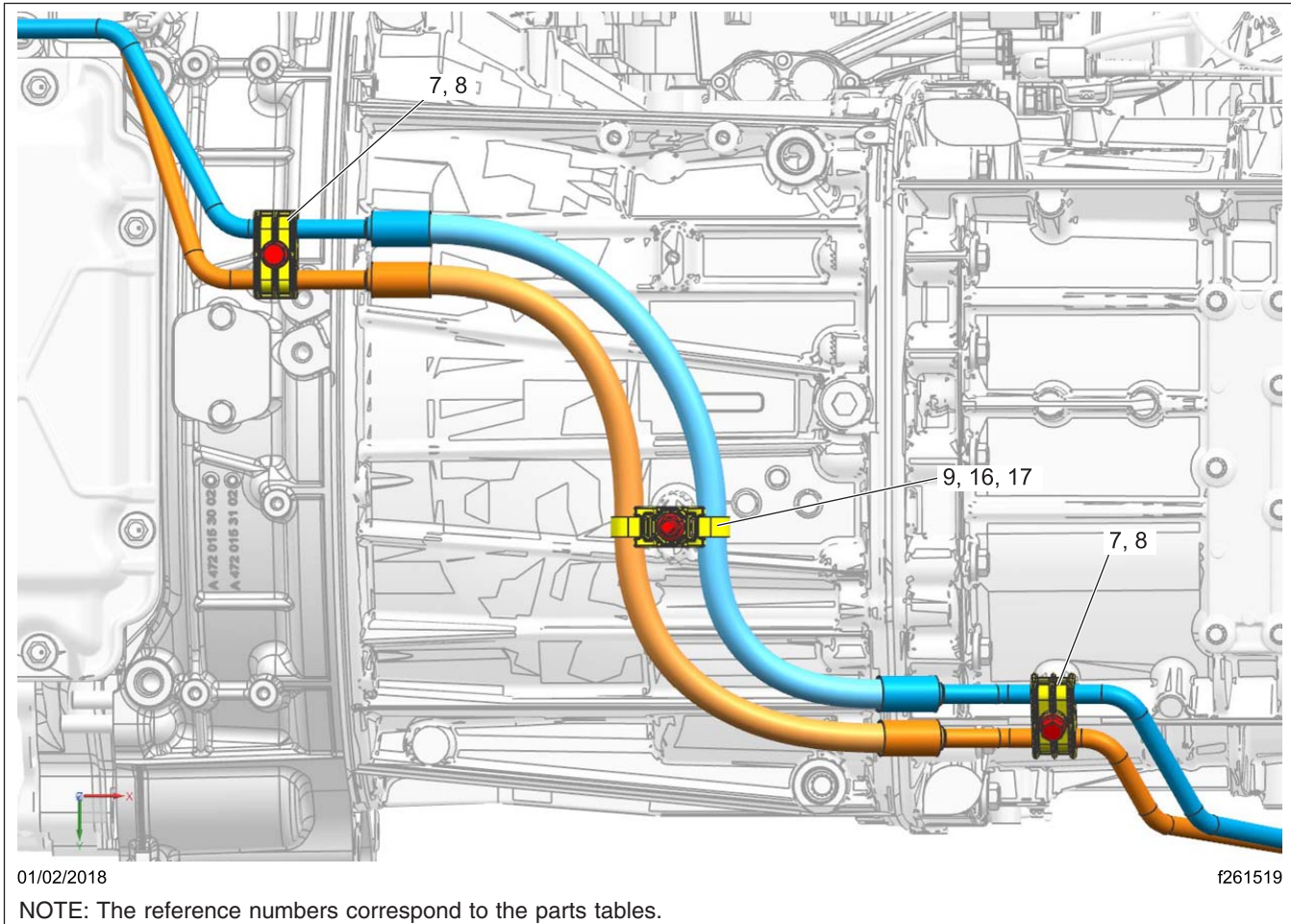
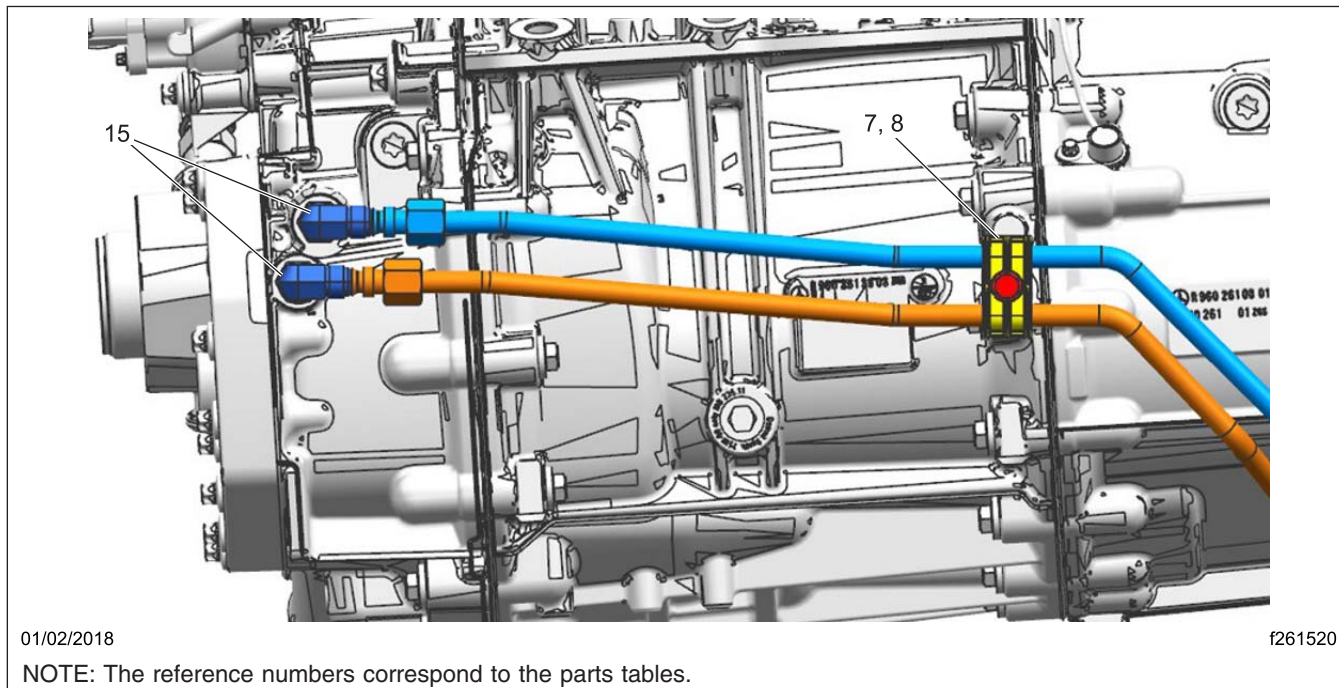

Fig. 22, Detail G (DD15)

Constellation  
Heritage  
4700 Models  
4800 Models

4900 Models  
> 5700 Models  
5900 Models  
6900 Models

Western Star  
Service Bulletin



**Fig. 23, Detail H (DD13 with DT12B transmission)**

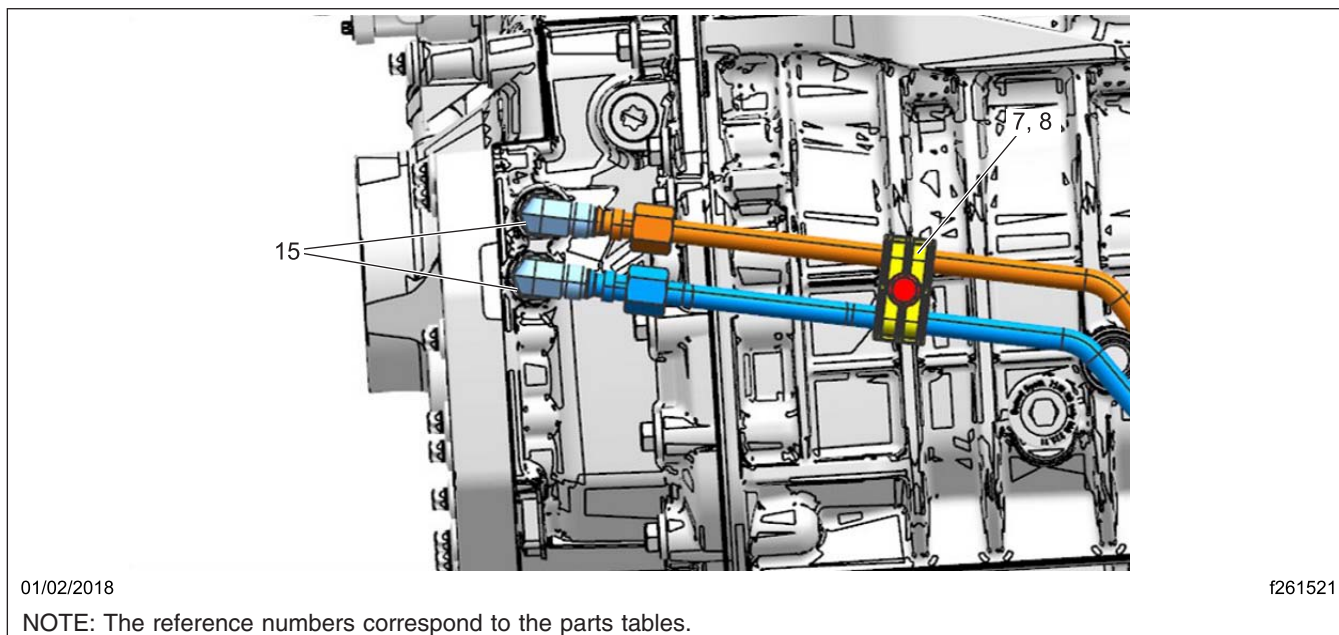

**Fig. 24, Detail J (DD15 with DT12A transmission)**

3. Tighten the line fittings 36 to 39 lbf·ft (49 to 53 N·m).
4. Tighten the cushion clamps 11 lbf·ft (15 N·m).
5. Install the butterfly tie in the front hose section (Ref. 10, [Fig. 18](#)).
6. Drive the vehicle until the oil temperature has reached 176°F (80°C), then top off the fluid to compensate for filling the cooler and the lines.

## Special Tool

Special tool DSN012T18001 is required to mark the drilling locations and drill the holes on the radiator frame.

## Parts

Parts are available from the PDCs. See the appropriate table, based on the transmission model (DT12A or DT12B), engine (DD13 or DD15), for required parts.

NOTE: If the vehicle has an existing oil cooler, new fittings (A 001 997 74 70) are not required.

Parts Required, BOM 383-T20001 (DT12B, DD13)			
Item Description	Reference Number	Part Number	Qty
TUBE-HOT,P3,DD13,DT12B	5	07-24613-000	1
TUBE-COLD,P3,DD13,DT12B	6	07-24614-000	1
BRKT-RAD SUPT,P3,DT12,AOC	18	07-24620-000	1
SPACER, TUBULAR ALUMINUM	13	23-11427-050	2
SWIVEL-90 DEG,8 C6X,FT	15	23-12135-002	2
SPACER-NYLON, .38 ID X .31 LG, .75 OD	21	23-12262-001	1
DUAL TUBE CLAMP,VNYL DIPPD,3/4	20	23-13629-075	2
CLAMP-COOLER LINE,TUBE SNAP VERSION	7	23-13687-000	12
SCREW-M8X60,8.8	22	N910105 008006	2
BOLT HEX HEAD FLANGE M8X1.25X16-10.9	11	DDE N910105008008	1
BOLT-M8X40,GRD8.8,DBL9440.40	8	N910143 008005	5
NUT,HX FLNG MTRC,M8X1.25,CLS 8	19	DDE N910112008000	1
NUT	9	DDE N000000003175	2
NUT-U,METRIC,M8X1.25	N/A	23-12625-010	4
NUT,INSERT	N/A	23-12631-381	1
BRACKET-SUPPORT,TRANS COOLER	12	A07-22753-001	1
TUBE-JUMPER,HOT,P3,AOC	3	A07-24611-002	1
TUBE-JUMPER,COLD,P3,AOC	4	A07-24612-002	1
TIE-STRAP,2 HOSES,.375 TO 2.25	10	TTYCDCT110HIR	1
COOLER-XMSN,DT12,P3/5700	N/A	07-24018-001	1
SCR-MACH,RHWC,HDI,DGPT,M8X25	50	23-13490-025	4
VALVE, OIL PUMP CONTROL, KIT	N/A	A 960 260 40 57	1
FITTING, OIL COOLER, M18X1.5/JIC	N/A	A 001 997 74 70	2 (not required if vehicle has an existing oil cooler)

Constellation  
Heritage  
4700 Models  
4800 Models

4900 Models  
> 5700 Models  
5900 Models  
6900 Models

Parts Required, BOM 383-T20001 (DT12B, DD13)			
SEALANT, ANAEROBIC	N/A	LOCTITE 518 or DDE23513509 or equivalent	1
CAP, -8 JIC	N/A	8 FNTX-S (or equivalent)	2 (only required if vehicle has an existing cooler)

**Table 1, Parts Required, BOM 383-T20001 (DT12B, DD13)**

Parts Required, BOM 383-T20003 (DT12A, DD13)			
Item Description	Reference Number	Part Number	Qty
TUBE-HOT,P3,DD13,DT12A	5	07-24615-000	1
TUBE-COLD,P3,DD13,DT12A	6	07-24616-000	1
BRKT-RAD SUPT,P3,DT12,AOC	18	07-24620-000	1
SPACER, TUBULAR ALUMINUM	13	23-11427-050	1
SWIVEL-90 DEG,8 C6X,FT	15	23-12135-002	2
SPACER-NYLON, .38 ID X .31 LG, .75 OD	21	23-12262-001	1
STRAP-TIE, DUAL, STAND OFF	17	23-13322-008	1
STUD DOUBLE END STL M8-1.25	16	23-13563-000	1
DUAL TUBE CLAMP, VNYL DIPPD,3/4	20	23-13629-075	2
CLAMP-COOLER LINE, TUBE SNAP VERSION	7	23-13687-000	12
SCREW-M8X60,8.8	22	N910105 008006	1
BOLT HEX HEAD FLANGE M8X1.25X16-10.9	11	DDE N910105008008	1
BOLT-M8X40,GRD8.8,DBL9440.40	8	N910143 008005	6
NUT, HX FLNG MTRC,M8X1.25,CLS 8	19	DDE N910112008000	1
NUT	9	DDE N000000003175	3
NUT-U,METRIC,M8X1.25	N/A	23-12625-010	4
NUT, INSERT	N/A	23-12631-381	1
BRACKET-SUPPORT, TRANS COOLER	12	A07-22753-001	1
TUBE-JUMPER,HOT,P3,AOC	3	A07-24611-002	1
TUBE-JUMPER,COLD,P3,AOC	4	A07-24612-002	1
TIE-STRAP,2 HOSES,.375 TO 2.25	10	TYCDCT110HIR	1
COOLER-XMSN,DT12,P3/5700	N/A	07-24018-001	1
SCR-MACH,RHWC,HDI,DGPT,M8X25	50	23-13490-025	4
VALVE, OIL PUMP CONTROL, KIT	N/A	A 960 260 40 57	1
FITTING, OIL COOLER, M18X1.5/JIC	N/A	A 007 997 74 70	2 (not required if vehicle has an existing oil cooler)
SEALANT, ANAEROBIC	N/A	LOCTITE 518 or DDE23513509 or equivalent	1

Parts Required, BOM 383-T20003 (DT12A, DD13)			
CAP, -8 JIC	N/A	8 FNTX-S (or equivalent)	2 (only required if vehicle has an existing cooler)

**Table 2, Parts Required, BOM 383-T20003 (DT12A, DD13)**

Parts Required, BOM 383-T20004 (DT12A, DD15)			
Item Description	Reference Number	Part Number	Qty
TUBE-HOT,P3,DD15,DT12A	5	07-24618-000	1
TUBE-COLD,P3,DD15,DT12A	6	07-24619-000	1
BRKT-RAD SUPT,P3,DT12,AOC	18	07-24620-000	1
SWIVEL-90 DEG,8 C6X,FT	15	23-12135-002	2
SPACER-NYLON, .38 ID X .31 LG, .75 OD	21	23-12262-001	1
STRAP-TIE, DUAL, STAND OFF	17	23-13322-008	1
BOLT-HEX, FLANGE HEAD-SCREW HEX FLANGE,M8	14	23-13345-020	1
BRACKET-ANGLE, STANDOFF	23	23-13426-005	1
STUD DOUBLE END STL M8-1.25	16	23-13563-000	1
DUAL TUBE CLAMP, VNYL DIPPD,3/4	20	23-13629-075	2
CLAMP-COOLER LINE, TUBE SNAP VERSION	7	23-13687-000	14
BOLT HEX HEAD FLANGE M8X1.25X16-10.9	11	DDE N910105008008	1
BOLT-M8X40,GRD8.8,DBL9440.40	8	N910143 008005	7
NUT, HX FLNG MTRC,M8X1.25,CLS 8	19	DDE N910112008000	1
NUT	9	DDE N000000003175	4
NUT-U, METRIC, M8X1.25	N/A	23-12625-010	4
NUT, INSERT	N/A	23-12631-381	1
BRACKET-SUPPORT, TRANS COOLER	12	A07-22753-001	1
TUBE-JUMPER,HOT,P3,AOC	3	A07-24611-000	1
TUBE-JUMPER,COLD,P3,AOC	4	A07-24612-000	1
TIE-STRAP,2 HOSES,.375 TO 2.25	10	TYCDCT110HIR	1
COOLER-XMSN,DT12,P3/5700	N/A	07-24018-001	1
SCR-MACH,RHWC,HDI,DGPT,M8X25	50	23-13490-025	4
VALVE, OIL PUMP CONTROL, KIT	N/A	A 960 260 40 57	1
FITTING, OIL COOLER, M18X1.5/JIC	N/A	A 001 997 74 70	2 (not required if vehicle has an existing oil cooler)
SEALANT, ANAEROBIC	N/A	LOCTITE 518 or DDE23513509 or equivalent	1
CAP, -8 JIC	N/A	8 FNTX-S (or equivalent)	2 (only required if vehicle has an existing cooler)

**Table 3, Parts Required, BOM 383-T20004 (DT12A, DD15)**

Constellation  
Heritage  
4700 Models  
4800 Models

4900 Models  
> 5700 Models  
5900 Models  
6900 Models

Western Star  
Service Bulletin

## Parts Documentation

Using the global annotation tool on PartsPro, identify the BOMs added/changed to the vehicle. See Parts Technical Bulletin 00-009 for the global annotation procedure. See [Table 4](#) for the BOM cross-reference list.

Using the approved parts documentation process, add a Global Annotation to the Vehicle Identification Number to identify the BoMs added/changed to the vehicle which provides information and traceability for future service and parts support.

- Add the new cooler, lines, and updated radiator BoM to module 266.
- Add the new baffle part number to BoM 278.
- Add the new BoM to the existing 342 module.

Original and New BOM Cross Reference			
Description	Original BoM/Part	New BoM/Part	Notes
	383-C05114	383-T20001	B-BOX, DD13, Western Star 5700
	383-C05137	383-T20001	B-BOX, DD13, Western Star 5700
	383-C05153	383-T20001	B-BOX, DD13, Western Star 5700
	383-C05171	383-T20001	B-BOX, DD13, Western Star 5700
	383-C05155	383-T20003	A-BOX, DD13, Western Star 5700
	383-C05173	383-T20003	A-BOX, DD13, Western Star 5700
	383-C05208	383-T20004	A-BOX, DD15, Western Star 5700
	383-C05228	383-T20004	A-BOX, DD15, Western Star 5700
	383-C05246	383-T20004	A-BOX, DD15, Western Star 5700
	383-C05255	383-T20004	A-BOX, DD15, Western Star 5700
	383-C05210	383-T20004	A-BOX, DD15, Western Star 5700
	383-C05229	383-T20004	A-BOX, DD15, Western Star 5700
	383-C05247	383-T20004	A-BOX, DD15, Western Star 5700
	383-C05256	383-T20004	A-BOX, DD15, Western Star 5700
	383-C05258	N/A	No ATOC Coverage - 1700 sq. inch RAD
	383-C05259	N/A	No ATOC Coverage - 1700 sq. inch RAD
Lower Baffle	A05-30679-000	A05-30679-002	
	A05-30679-001	A05-30679-002	
	A05-31358-000	A05-31358-002	
	A05-31358-001	A05-31358-002	
	A05-30936-000	A05-31358-002	
Cooler	N/A	370-C12700	
Radiator	266-C20601	266-C20614	Western Star 5700
	266-C20603	266-C20615	Western Star 5700
	266-C20605	266-C20616	Western Star 5700
	266-C20607	266-C20617	Western Star 5700
	266-C20814	N/A	

Original and New BOM Cross Reference			
Transmission	342-C92045	342-C92292	
	342-C92719	342-C92720	
	342-C92041	342-C92290	
	342-C92112	342-C92042	
	342-C88302	342-C91916	
	342-C92109	342-C92772	
	342-C93187	342-C91916	Swap the driveline flange to the new trans.
	342-C92962	342-C92772	Swap the driveline flange to the new trans.
	342-C93224	342-C92772	
	342-C88482	342-C88347	
	342-C91687	342-C91856	
	342-C92111	342-C93215	
	342-C93216	342-C93215	
	342-C92113	342-C93214	
	342-C93222	342-C93214	

**Table 4, Original and New BOM Cross Reference**

## Warranty

This is an informational bulletin only. Warranty does not apply.