



Service Bulletin

Bulletin No.: 20-NA-074

Date: June, 2020

TECHNICAL

Subject: Front Fascia Paint Chipping at Headlamp Opening

Attention: BULLETIN CAN ONLY BE REFERENCED AND CLAIM MADE ONCE THE VEHICLE HAS BEEN SOLD TO THE CUSTOMER. VEHICLES IN DEALERS STOCK INVENTORY CANNOT BE REPAIRED.

Brand:	Model:	Model Year:		VIN:		Engine:	Transmission:
		from	to	from	to		
Cadillac	XT4	2019	2020	—	—	All	All

Involved Region or Country	North America, Middle East, China, Europe, Israel
Condition	Some customers may comment on seeing the paint chipping on either, or both sides, of the front fascia at the headlamp opening.
Cause	The cause of the condition may be a tight, or interference, condition between the headlamp and fascia, and the headlamp lacks any protective tape in those areas.
Correction	Important: Bulletin can only be referenced and claim made once the vehicle has been sold to the customer. Vehicles in Dealers stock inventory cannot be repaired. Remove and reinstall the front fascia, repair fascia paint as necessary and add mylar tape to BOTH headlamps, following the steps in the Service Procedure below.

Service Procedure

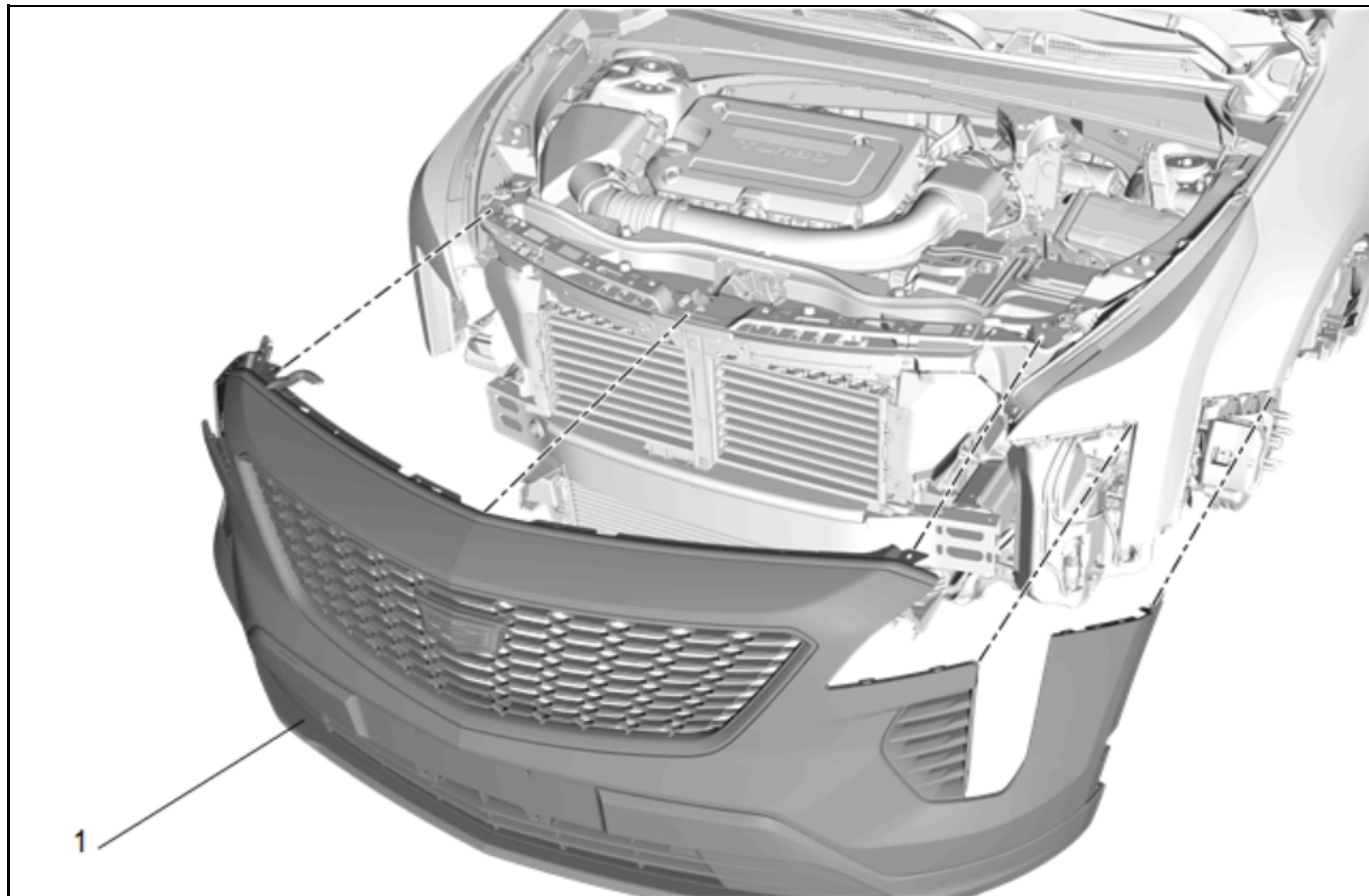

5069634

1. Remove the front fascia (1). Refer to *Front Bumper Fascia Removal and Installation* in SI.

Note: Refer to the latest revision of the GM Approved Refinish Materials book to identify the paint systems you may use that have been engineered to meet GM standards.

The latest revision of the GM Approved Refinish Materials booklet is located on the Genuine GM Parts website at www.genuinegmparts.com and also within the "Unit Repair Manual/Specialty Publication" section of GM Service Information (SI).

2. Complete a partial paint repair to the affected location(s) of the front fascia.

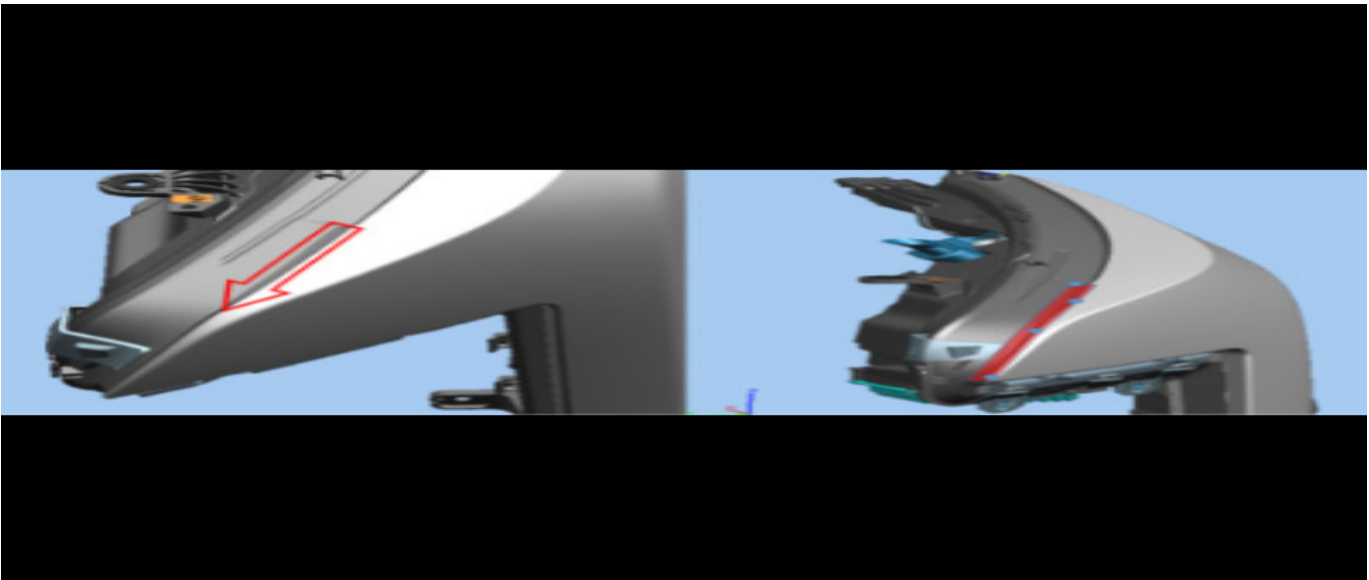

5549102

3. Using a mixture of isopropyl alcohol and water, spray the mixture onto a cloth and wipe any dirt debris from both headlamps, in the area shown in the graphic above. Then, let air dry.

4. Apply 1 mylar tape strip to each headlamp ensuring to follow the positioning and steps below:

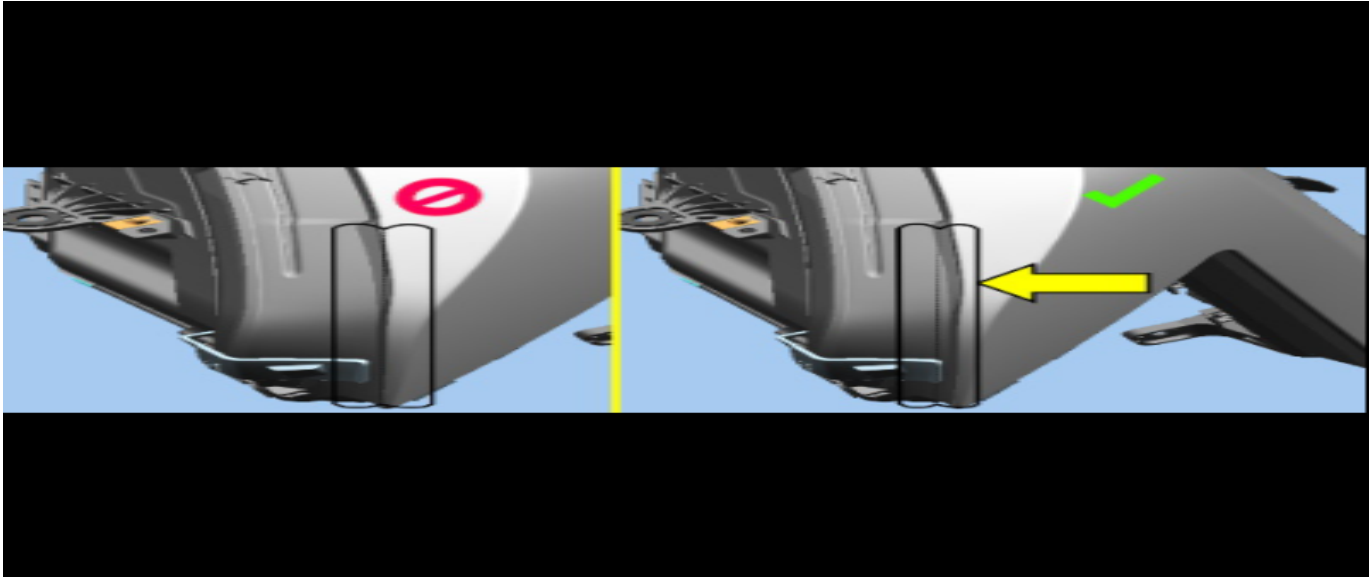

- 4.1. Start application of mylar tape by removing the liner from the narrower surface side.

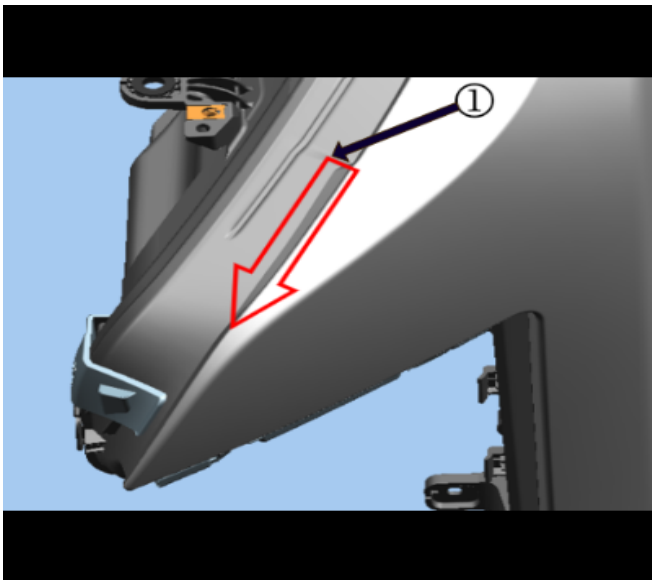

- 4.2. Align the top notch of the mylar tape with the character line change (1) on the lamp lens. This is where the headlamp interference with the hood starts.

5549105

Note: Ensure to route the tape under the lamp bracket.

- 4.3. Align the edge of the tape along the transition point of light to dark on the lamp lens, and align the bottom notch to the bottom of the lamp lens.
 - 4.4. Working from top to bottom, firmly press the tape to fully wet out the complete length.
 - 4.5. Remove the liner from the wider, backside surface of the tape by feeding it under the lamp bracket.
 - 4.6. Again, working from top to bottom, firmly press the tape to fully wet out the complete length. Use of a squeegee may be helpful in pressing the tape into the corners.
 - 4.7. Lastly, fully wet out the top of the tape by pressing down into the top corner of the lamp lens.
5. Repeat step #4 on the other side headlamp.

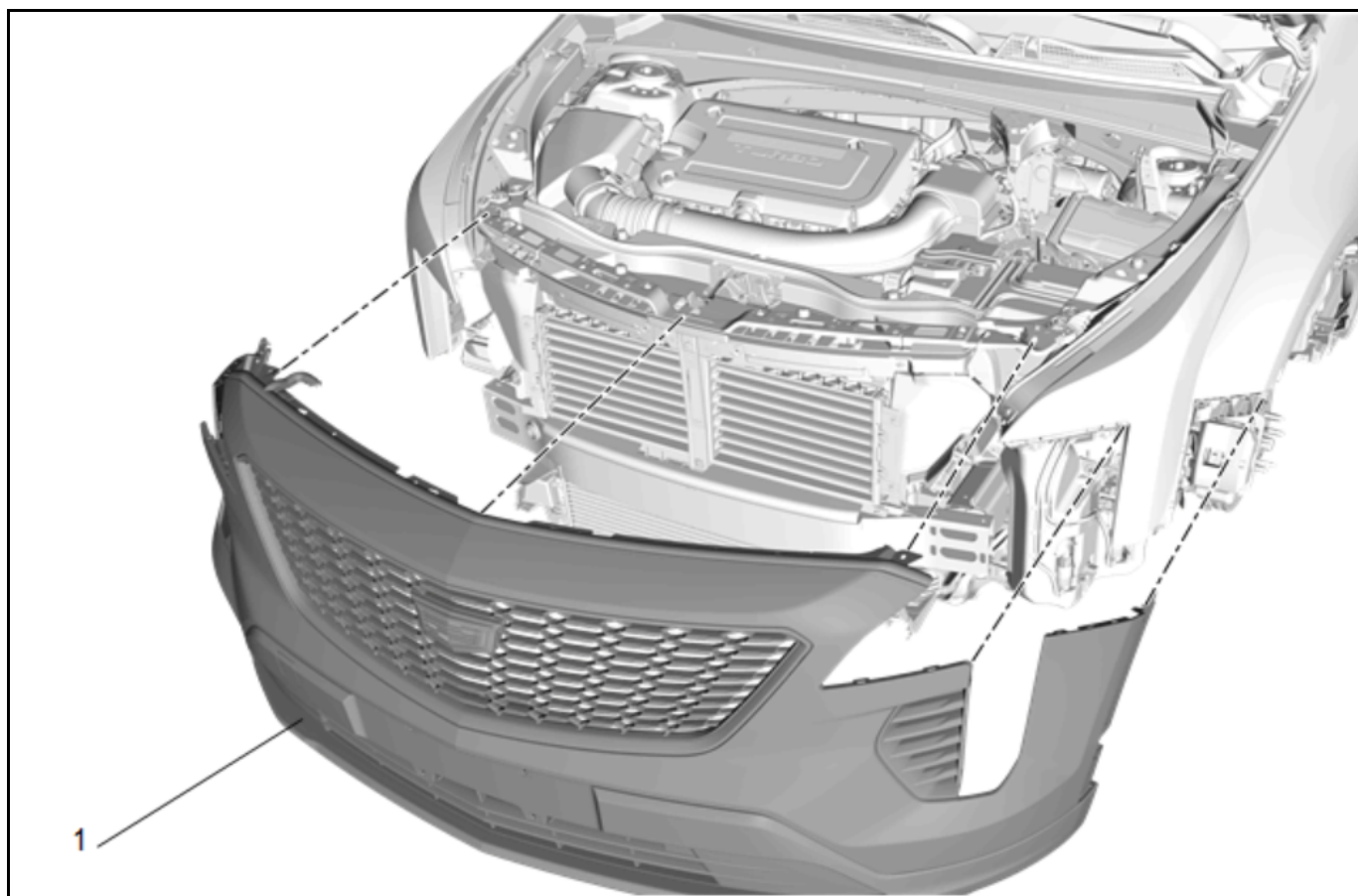

5069634

6. Reinstall the front fascia (1). Refer to *Front Bumper Fascia Removal and Installation* in SI.

Parts Information

Causal Part	Description	Part Number	Qty
N/A	SPACER-HDLP MT	84886183	1

Labor Operation	Description	Labor Time	Paint Code
1481308*	Remove and Reinstall Front Fascia, Partial Refinish Color/Clear Coat Fascia, Apply Mylar Tape	3.5 hrs **	AK
Add	With Tint Coat/Tri-Coat Paint	0.3 hr	GB

*This is a unique Labor Operation for bulletin use only.
 **Includes Paint Mix Time

Warranty Information

For vehicles repaired under the Bumper-to-Bumper coverage (Canada Base Warranty coverage), use the following labor operation. Reference the Applicable Warranties section of Investigate Vehicle History (IVH) for coverage information.

Version	2
Modified	Released May 08, 2020 June 23, 2020 – Updated the Attention and Important statements and added the Labor Operation number.

GM bulletins are intended for use by professional technicians, NOT a "do-it-yourselfer". They are written to inform these technicians of conditions that may occur on some vehicles, or to provide information that could assist in the proper service of a vehicle. Properly trained technicians have the equipment, tools, safety instructions, and know-how to do a job properly and safely. If a condition is described, DO NOT assume that the bulletin applies to your vehicle, or that your vehicle will have that condition. See your GM dealer for information on whether your vehicle may benefit from the information.



WE SUPPORT VOLUNTARY
TECHNICIAN
CERTIFICATION