



SERVICE BULLETIN

Classification: EM20-004	Reference: NTB20-053	Date: July 20, 2020
-----------------------------	-------------------------	------------------------

2020 TITAN 4WD; VIBRATION WHILE DRIVING ABOVE 3,500 RPM

APPLIED VEHICLES: 2020 Titan (A61)
APPLIED DRIVETRAIN: 4WD

NOTE:
This bulletin does not apply to Titan XD.

IF YOU CONFIRM

A vibration is present while driving with the engine speed above 3,500 RPM.

ACTION

1. Diagnose the fan coupler.
2. Install the fan coupler kit listed in **PARTS INFORMATION**, if applicable. The fan coupler kit includes a new fan coupler, fan pulley and fan bracket.

IMPORTANT: The purpose of ACTION (above) is to give you a quick idea of the work you will be performing. You **MUST** closely follow the entire SERVICE PROCEDURE as it contains information that is essential to successfully completing this repair.

Nissan Bulletins are intended for use by qualified technicians, not 'do-it-yourselfers'. Qualified technicians are properly trained individuals who have the equipment, tools, safety instruction, and know-how to do a job properly and safely. **NOTE:** If you believe that a described condition may apply to a particular vehicle, DO NOT assume that it does. See your Nissan dealer to determine if this applies to your vehicle.

SERVICE PROCEDURE

IMPORTANT: Before starting, make sure:

- ASIST on the CONSULT PC has been synchronized (updated) to the current date.
- All C-III plus software updates (if any) have been installed.
- The CONSULT PC is connected to the Internet (Wi-Fi or cable).

NOTE:

Before starting this procedure, ensure the engine coolant temperature is 178-203 °F (81-95 °C).

1. Connect the C-III plus VI to the vehicle.
2. Open C-III plus on the CONSULT PC.
3. Turn the ignition ON, but do not start the engine.
4. Select **Diagnosis One System**.
5. Select **ENGINE**.
6. Select **Data Monitor**.
7. Clear all **Data Monitor** items.
8. Select the following parameters in **Data Monitor**:
 - **ENG SPEED**
 - **COOLANT TEMP/S**
 - **COOLING FAN SPD**
 - **FAN DUTY**
9. Start the engine.
10. Using the accelerator pedal, increase the engine speed by approximately 1,000 RPM per second until 5,500 RPM is achieved, then allow the engine speed to return to idle.
11. Perform step 10 a total of five (5) times while observing the **COOLING FAN SPEED**.
 - If the **COOLING FAN SPEED** does not reach 900 RPM or higher, this bulletin does not apply. Return to the ESM for further diagnostic and repair information.
 - If the **COOLING FAN SPEED** reaches 900 RPM or higher, continue to step 12 on page 3.

12. Obtain a screen shot, photo or video of **Data Monitor** (Figure 1) showing the following:

- **ENG SPEED** 3,500 RPM or above
- **COOLANT TEMP/S** 178-203 °F (81-95 °C)
- **COOLING FAN SPEED** 900 RPM or above
- **FAN DUTY** 0 %
- **VIN**

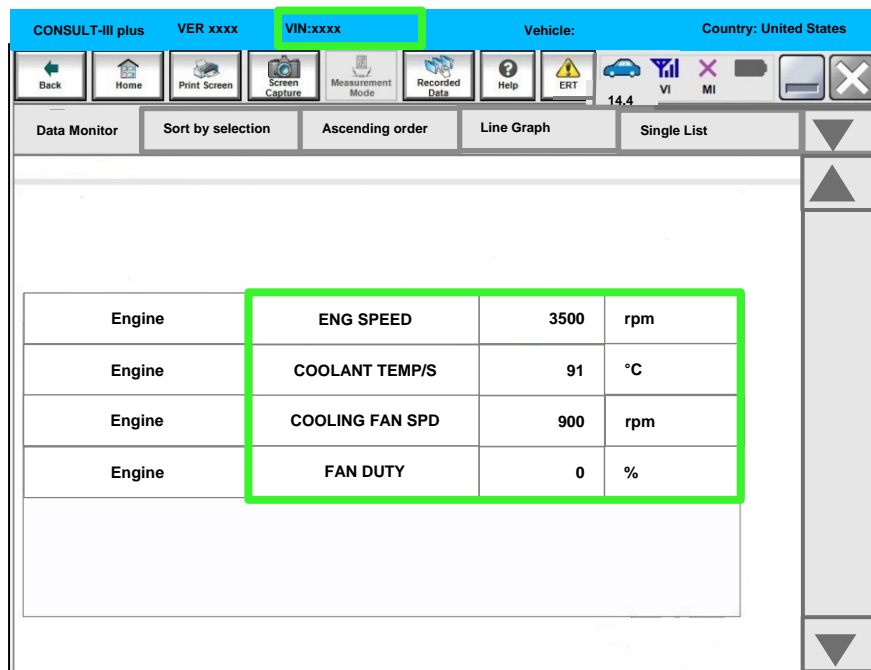

Figure 1

13. Complete the PCC Assistance Request Form in ASIST (Figure 2).

- a. Enter **Dealer Code**.
- b. Enter **17 Digit VIN**.
- c. Select **New Engine Form**.
- d. Select **Next**.

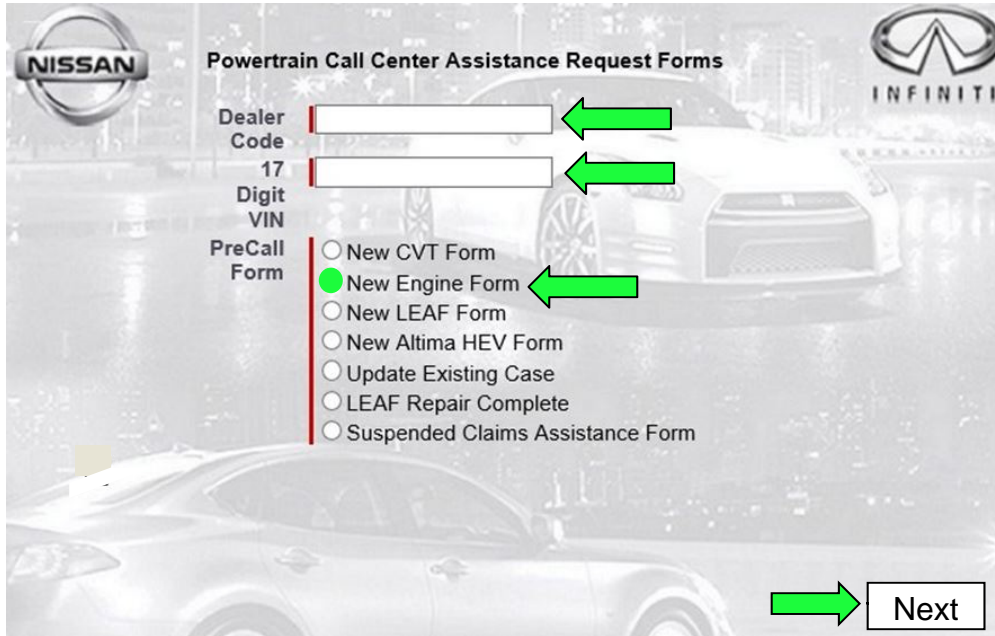

Figure 2

- e. Attach the screen shot, photo or video of **Data Monitor** collected from C-III as described in step 12 on page 3.
- f. After submitting the Assistance Request Form with the attached image, call the PCC at 800-973-9992 (opt 1) for repair pre-approval.

14. Remove the fan bracket (1), fan pulley (2) and the fan coupler (3) (see Figure 3).
- Refer to the ESM for removal of the fan bracket, fan pulley, and the fan coupler:
ENGINE > ENGINE COOLING SYSTEM > VK56VD > REMOVAL AND INSTALLATION > COOLING FAN.

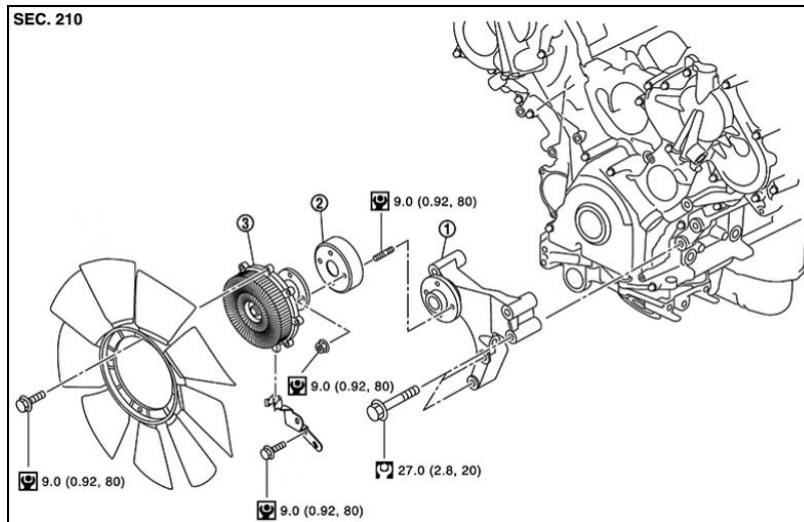

Figure 3

15. Install the new fan bracket (see **PARTS INFORMATION** on the last page of this bulletin).
- Upon installation of the fan bracket, hand tighten but **DO NOT** torque the fan bracket bolts.
 - Torque the shared A/C compressor/fan bracket bolt first (Figure 4), then torque the remaining fan bracket bolts.

HINT: Figure 2 is shown with the idler pulley and the fan pulley installed, but these pulleys will remain removed during fan bracket installation.

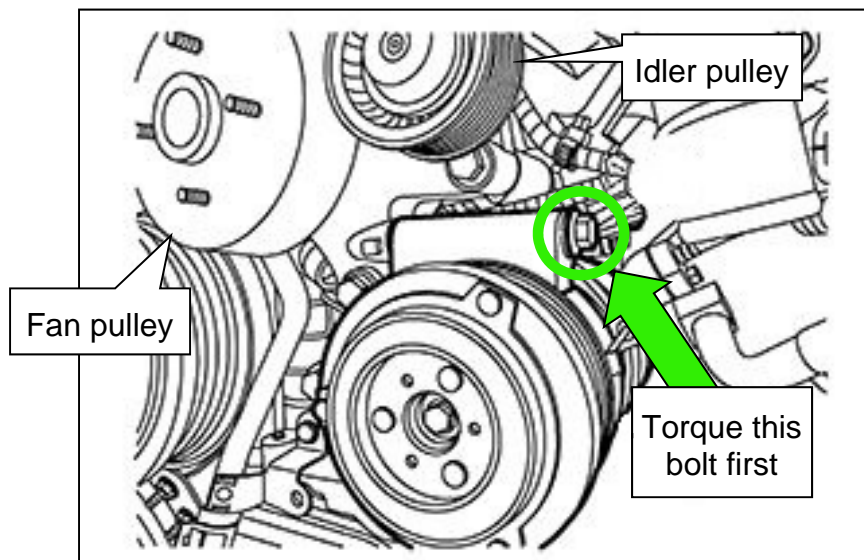

Figure 4

16. Install the remaining components in the reverse order of removal.

- Refer to the ESM: ENGINE > ENGINE COOLING SYSTEM > VK56VD > REMOVAL AND INSTALLATION > COOLING FAN.
- During installation of the new fan pulley and fan coupler, ensure the paint reference marks are aligned (see Figure 5).

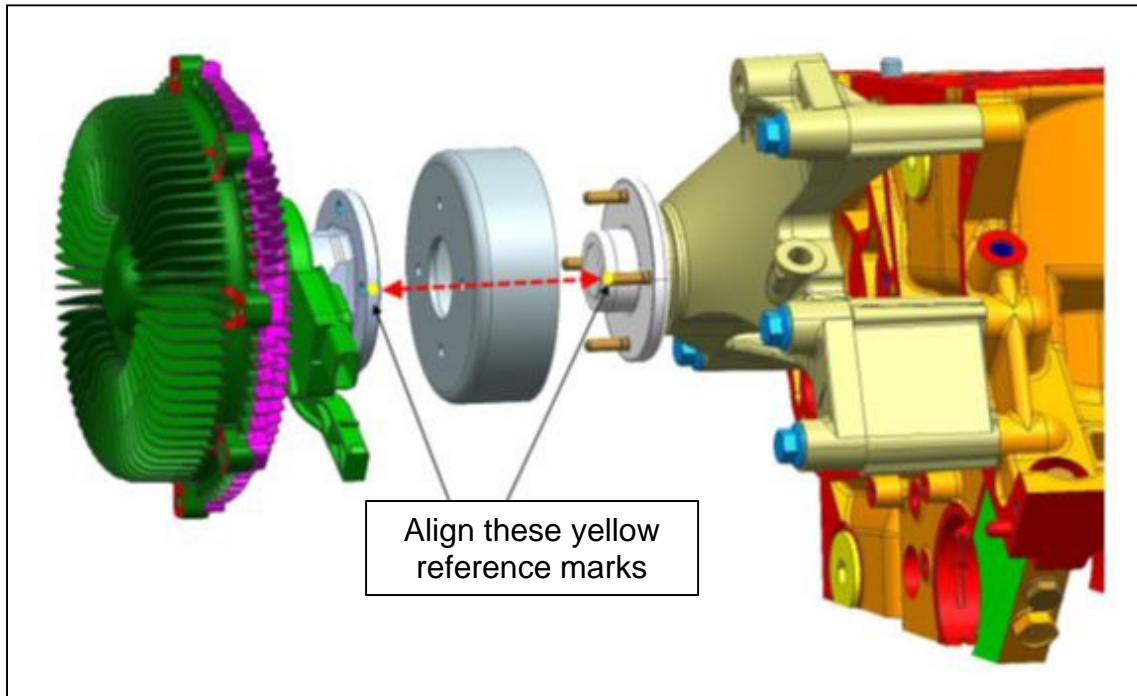

Figure 5

PARTS INFORMATION

DESCRIPTION	PART NUMBER	QUANTITY
Fan Coupler Kit	21084-1LA8A	1

CLAIMS INFORMATION

Submit a Primary Part (PP) type line claim using the following claims coding:

DESCRIPTION	PFP	OP CODE	SYM	DIA	FRT
Check Cooling Fan Speed	(1)	CX35AA	ZN	32	0.2
Check Cooling Fan Speed & Install Fan Coupler Kit		CX36AA			1.4

(1) Reference the electronic parts catalog and use the Fan Coupling (21082-*****) as the Primary Failed Part (PFP).

AMENDMENT HISTORY

PUBLISHED DATE	REFERENCE	DESCRIPTION
July 20, 2020	NTB20-053	Original bulletin published

