

## Back Of Cab Crack, Repair LR

### FSB 810-004, Back of Cab Crack, Repair

(July 2020)

Certain Mack LR model trucks may experience crack on the back of cab. Mack Trucks determine to replace the existing panel kit of engine cover with new panel kit.

Follow the instruction outlined in this FSB to repair the crack on the back of cab and to replace the panel kit of engine cover.

#### Required Parts

Part Description	New part number	Quantity
Engine cover, panel kit	78586554	1

## Procedure

You must read and understand the precautions and guidelines in Service Information, group 8, "General Safety Practices, Brakes" before performing this procedure. If you are not properly trained and certified in this procedure, ask your supervisor for training before you perform it.

**NOTE:** Information is subject to change without notice. Illustrations are used for reference only and can differ slightly from the actual vehicle being serviced. However, key components addressed in this information are represented as accurately as possible.

- 1 Park the vehicle on a level surface with the steering wheel in the straight ahead position.
- 2 Apply the parking brake.
- 3 Place the gear lever in neutral or park.
- 4 Install the wheel chocks.

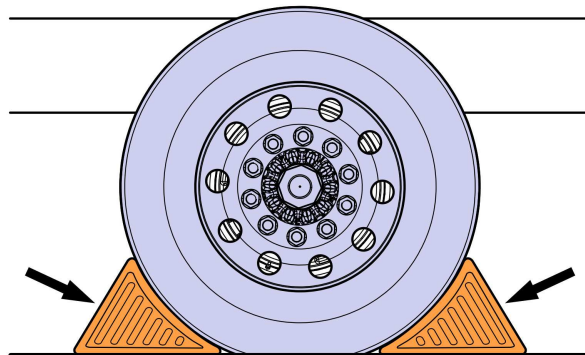

W7086748

5 Disconnect the cable from the battery's negative terminal.

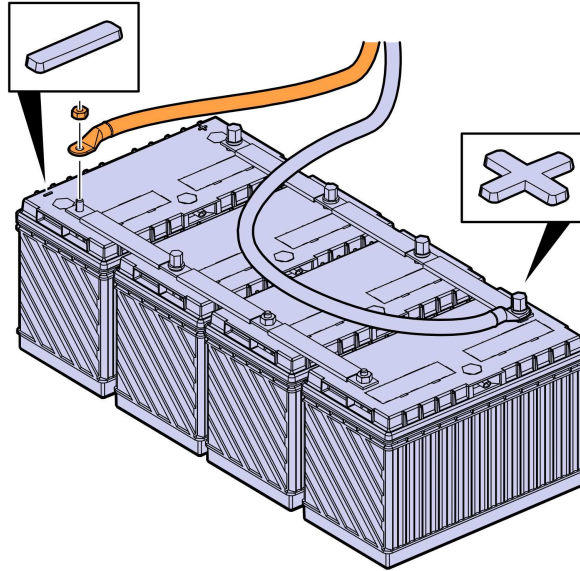

W3086747



**CAUTION**

**Risk of material damage.**

Failure to secure loose material in the cab before tilting may result in material damage. Secure all loose material within the cab before tilting.



**CAUTION**

**Risk of material damage.**

Damage may occur to the cab. Make sure that there is adequate space in front of the vehicle before tilting the cab.



**WARNING**

**Risk of serious injury.**

A cab that is not tilted to the end position constitutes a safety risk. Always tilt the cab to the end position. Never perform any work under the cab before it has been tilted to the end position.

6 Tilt the cab forward.

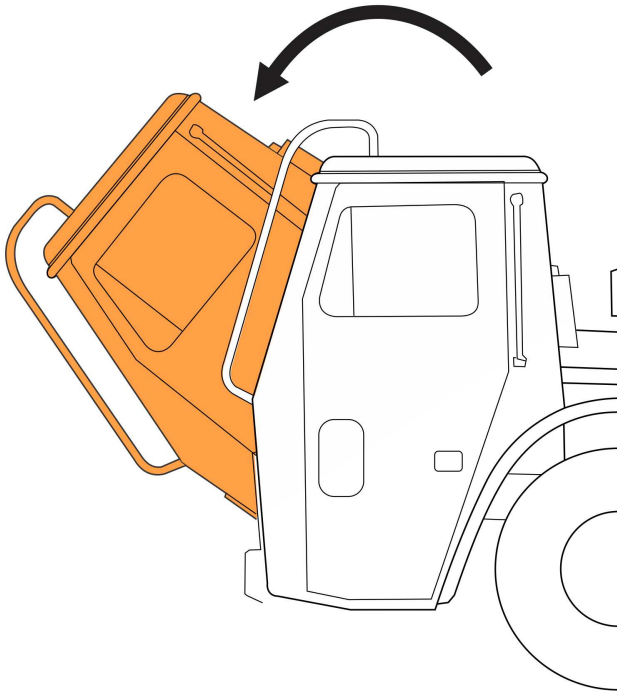

T8160359

7 Remove the nuts and washers.

8 Remove the panel.

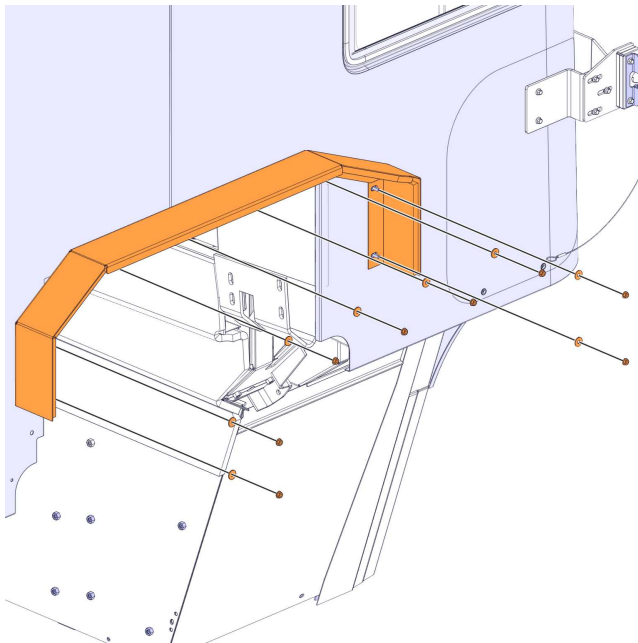

T8159766

9 Drill a stop hole at the end of crack. Weld and repair the crack on the back of cab.



T8159770

10 Remove the M6 studs.

**Note:** Do not remove all the studs. Remove only the highlighted studs as shown in the illustration.

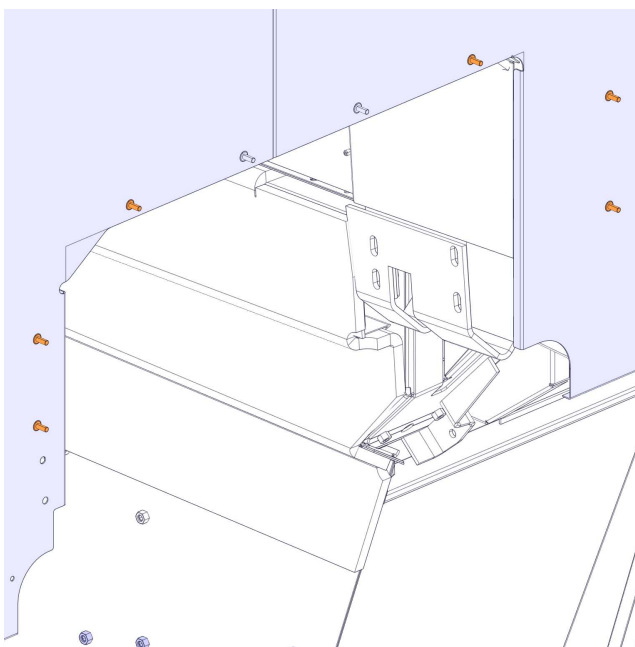

T8159767

11 Weld and close the stud holes.

**Required part**

Part Description	New part number	Quantity
Engine cover, panel kit	78586554	1

12 Position the panel.

**Note:** Use existing studs (remaining M6 studs) to position the panel.

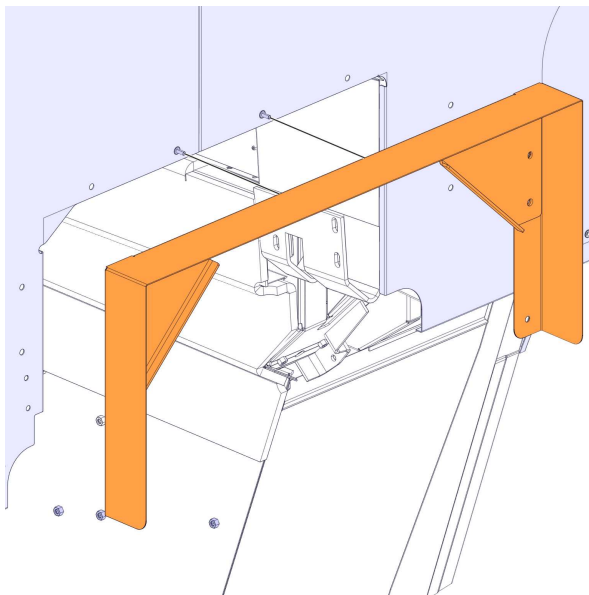

T8159768

13 Mark the position of panel holes in BIW (Body In White) for the new rivet nuts.

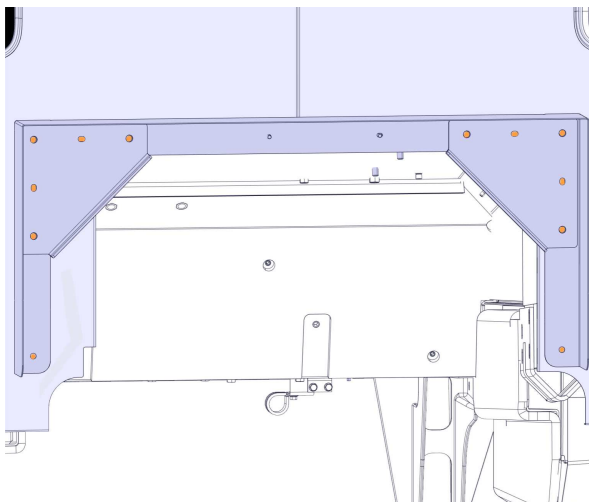

T8160363

14 Remove the panel.

15 Drill holes in the BIW.

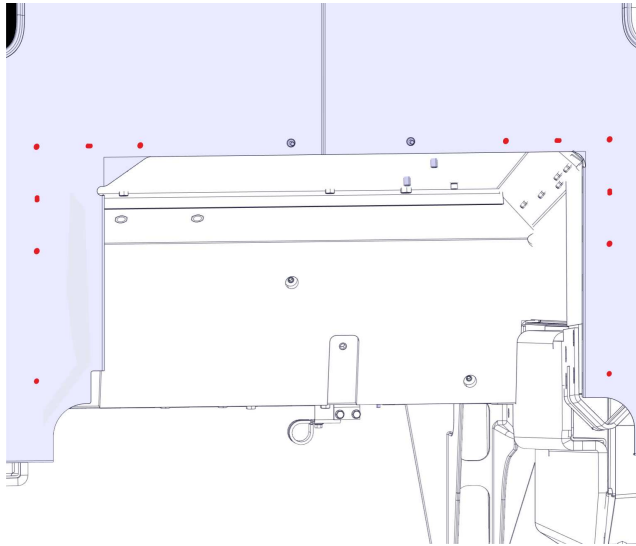

T8160364

16 Install the M8 rivet nuts.

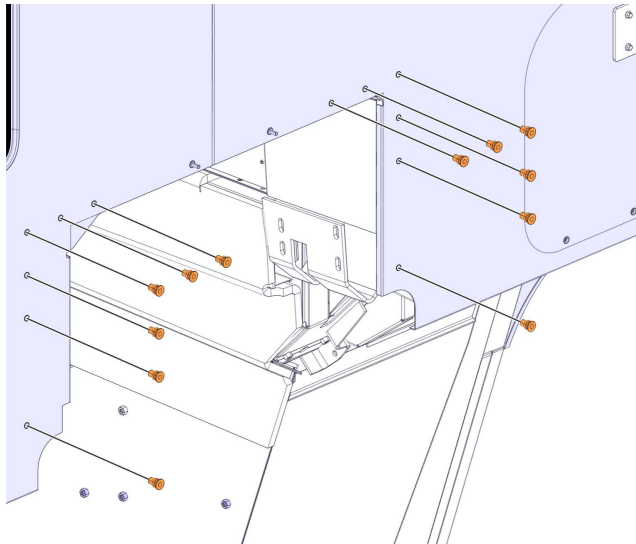

T8160365

17 Position the panel.

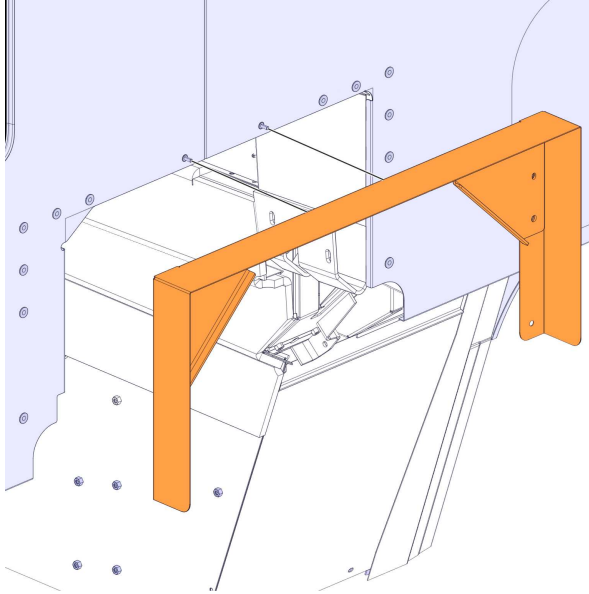

T8160366

18 Install the screws.

**Note:** The screws to run through the saddlebag upright panel that is behind the outer skin panel of rear wall.

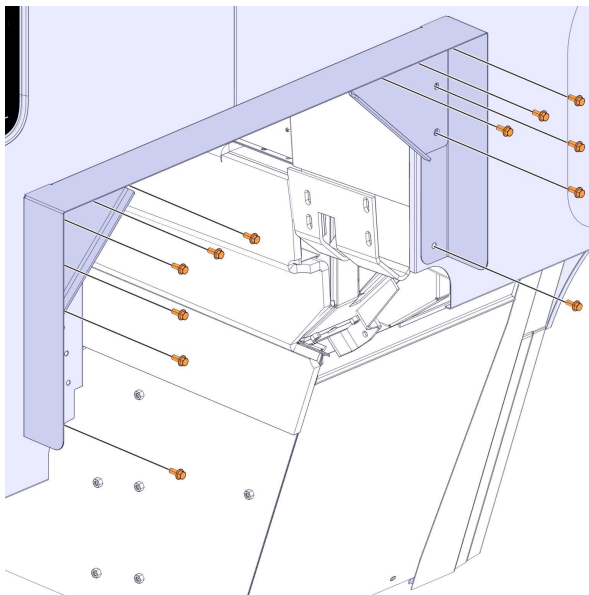

T8159769

19 Torque tighten the screws.

Tightening torque	$25 \pm 2.5 \text{ Nm}$ ( $18.5 \pm 1.8 \text{ ft-lb}$ )
-------------------	--

20 Install the washers and nuts.

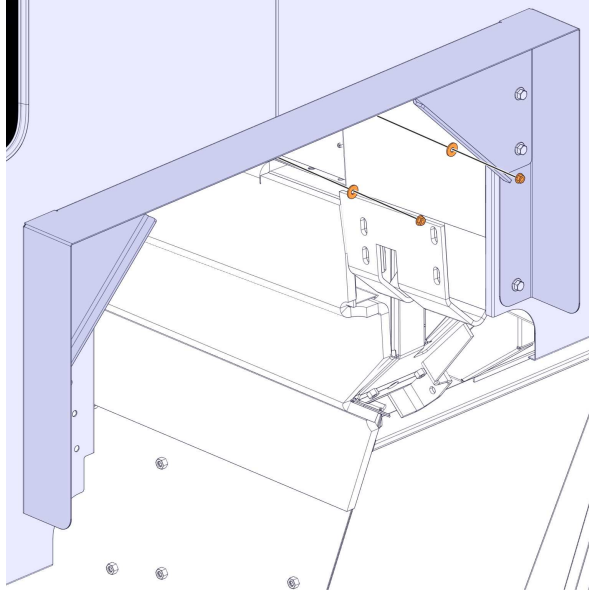

T8160367

21 Torque tighten the nuts.

Tightening torque	10.5 ± 1.5 Nm (7.75 ± 1 ft-lb)
-------------------	--------------------------------

22 Tilt back the cab.

**Note:** Ensure that the cab locks are engaged.

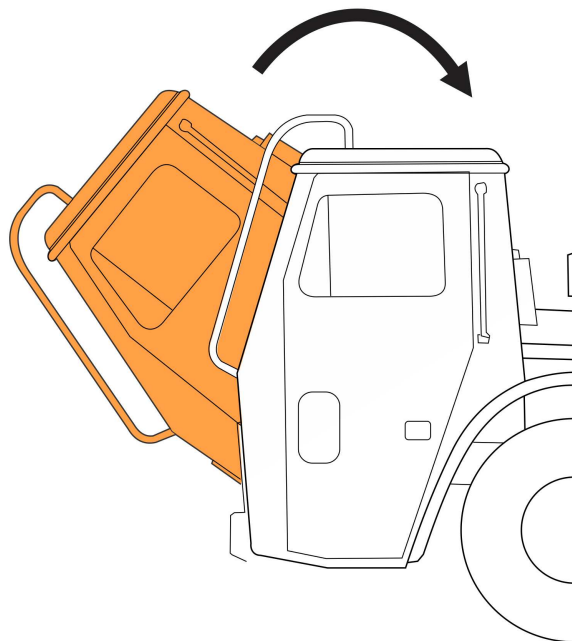

T8160360

23 Connect the battery cable to the negative (ground) terminal.

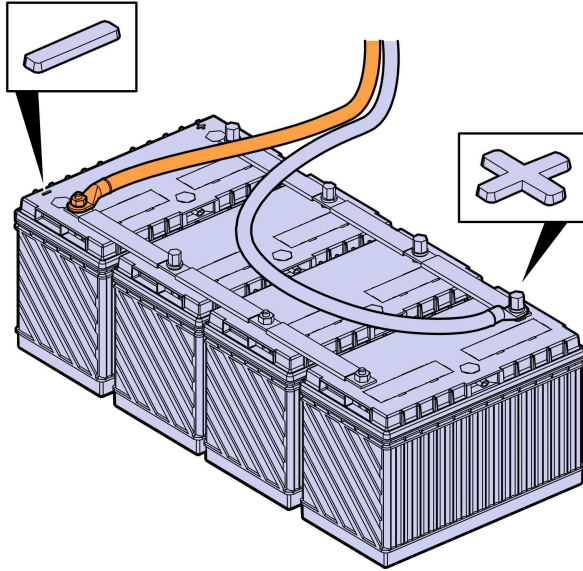

W3086758

24 Remove the wheel chocks.

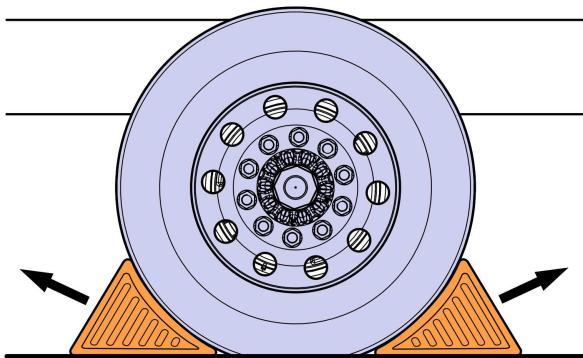

W7086759

**Reimbursement**

<b>This repair may be eligible for reimbursement if a product failure was experienced within time and mileage limits of the applicable warranty coverage. Reimbursement is obtained via the normal claim handling process.</b>	<b>UCHP Reimbursement</b>
<b>Claim type (used only when uploading from the dealer Bus. Sys.)</b>	01
<b>Labour Code</b>	
Back Of Cab Crack, repair	8102-16-09-01 (5.0 hrs)
<b>Causal Part</b>	84169992

Mack Trucks reserves the right to make any changes in design or to make additions to or upon its products without incurring any obligations to install the same on vehicles previously built.