



## Mack CarPlay Update with Hardware

**Description:**

Some Mack trucks were built with an infotainment unit that does not support Apple CarPlay. To enable CarPlay, the infotainment hardware must be replaced and additional software must be installed directly to the infotainment unit. The software update process does not use TechTool. This update also includes updated navigation maps.

**Corrective Action:**

Replace the infotainment display and SEM (Service and Entertainment Module). Refer to Special Tools Bulletin STB20-002M and use the USB stick to update the software according to the campaign instructions. The USB stick is preloaded with the appropriate software.

**UCHP SCC CODE:** S7483

**EXPIRATION DATE:** 5/30/2021

**CAUSAL PART NUMBER:** 22375442

**UCHP Labor Code:**

1720-16-09-01 – Campaign, General – 0.9

3931-03-02-04 – Infotainment Control Unit, Replacement – 0.5

**PARTS MARKUP:** 30%

**PARTS LIST:**

PN – Description – QTY

22375442 – RADIO, SEM UNIT – 1

22814964 – DISPLAY PANEL – 1

23750818 – USB UPDATE Mack with navigation – provided

23750820 – USB UPDATE Mack without navigation – provided

**FOR MORE INFORMATION CONTACT:** Sean Gallagher

[sean.gallagher@volvo.com](mailto:sean.gallagher@volvo.com)

## Decommissioning the Truck for Repair

You must read and understand the precautions and guidelines in Service Information, group 30, "General Safety Practices, Electrical" before performing this procedure. If you are not properly trained and certified in this procedure, ask your supervisor for training before you perform it.

NOTE: Information is subject to change without notice. Illustrations are used for reference only and can differ slightly from the actual vehicle being serviced. However, key components addressed in this information are represented as accurately as possible.

1. Park the vehicle on a flat and level surface.
2. Apply the parking brake.
3. Place the transmission in neutral or park.
4. Install the wheel chocks.

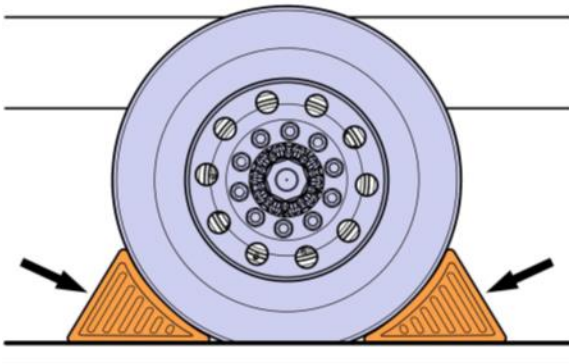

5. Disconnect the battery.

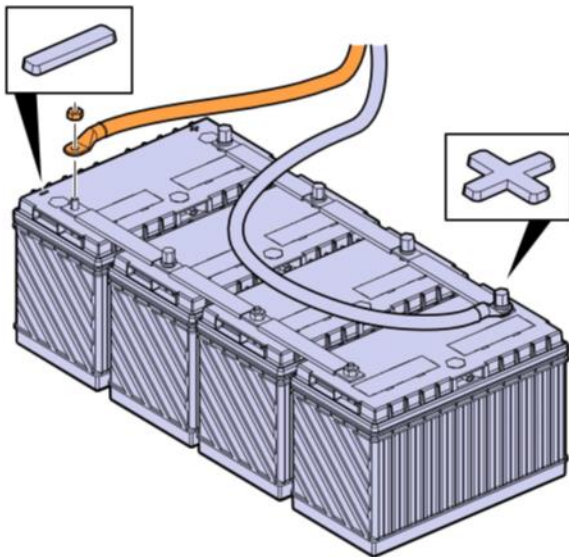

## Replacing Infotainment Display

1. Install the tools. Remove the display.

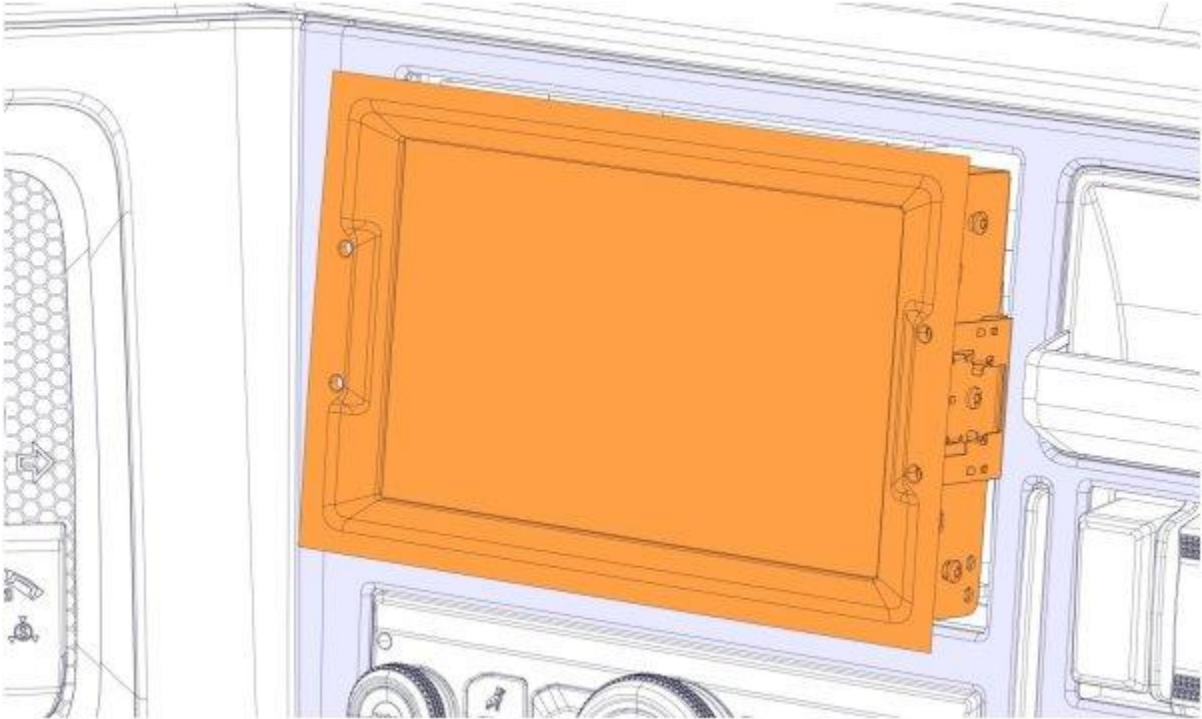

2. Disconnect the connectors.
3. Connect the connectors and install the new display.

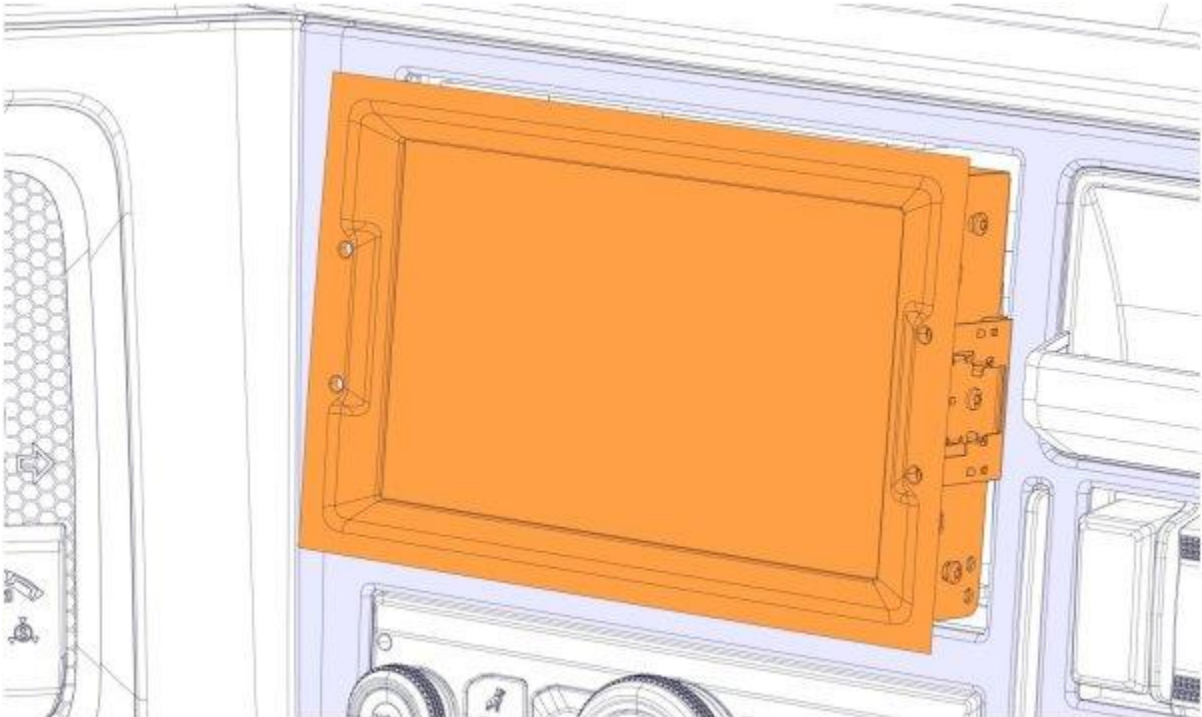

## Replacing Infotainment SEM (Service and Entertainment Module)

1. Install the radio tools. Remove the SEM.

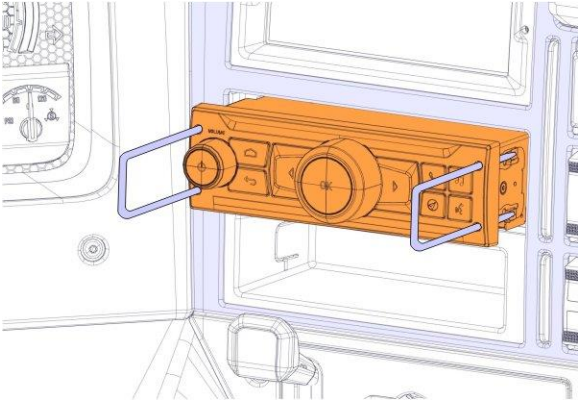

2. Disconnect the connectors.
3. Record the serial number of the new infotainment control unit in case troubleshooting is necessary.

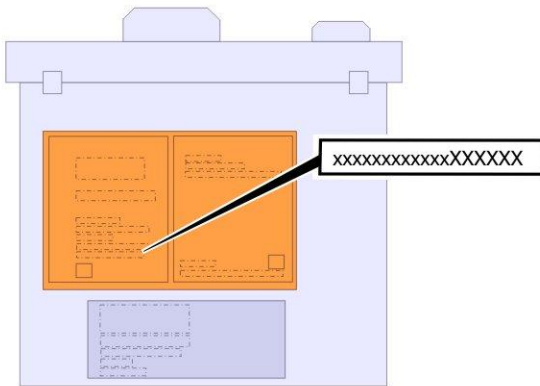

4. Connect the connectors.
5. Install the new SEM.

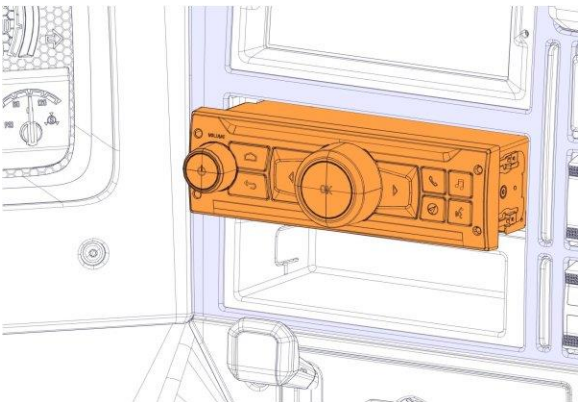

## Prepare the Truck for Software Update

1. Connect the battery cable to the negative (ground) terminal.

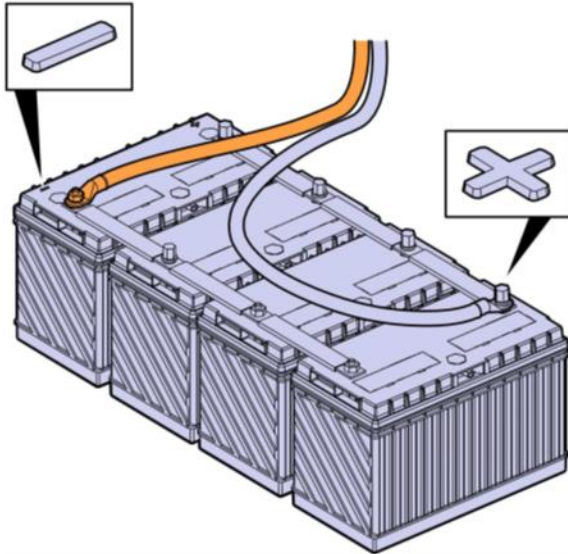

2. Check the battery voltage. **The battery voltage must be greater than 12V. The batteries must remain connected throughout the software update process. The key must remain in the Run position. Do not start the truck or turn the key to Off.**
3. Place the USB stick PN 23750818 into the dash. **Note: using an incorrect USB stick will cause software issues. Do not remove the USB stick until all programming operations are complete.**



## Software Update Procedure

1. From the Home Screen, Go to the Settings Menu by swiping to the right from the Home Screen and select "System settings":

Note: If the popup menu "New files found" is displayed, select "No". Those files will be updated in Update Voice Recognition and Navigation/Map Files Procedure on page 8.

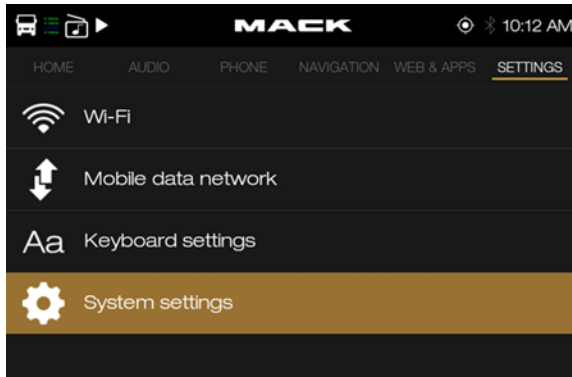

2. Select on "About" (swipe to the top if needed)

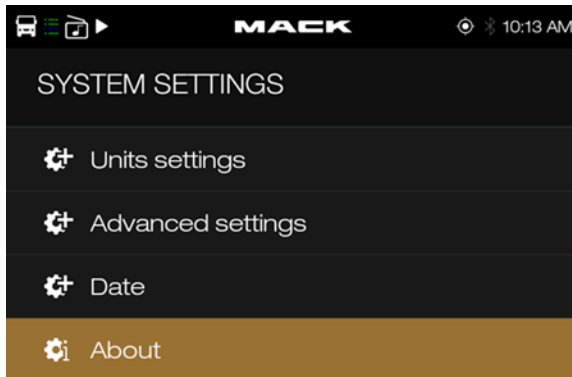

3. Then select "Update Product" and "Update from Thumb drive"

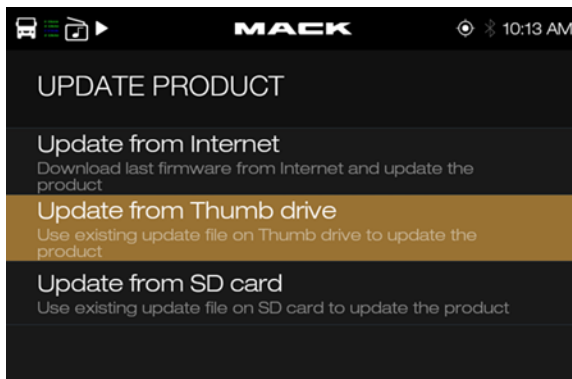

- The product will restart and begin updating software automatically

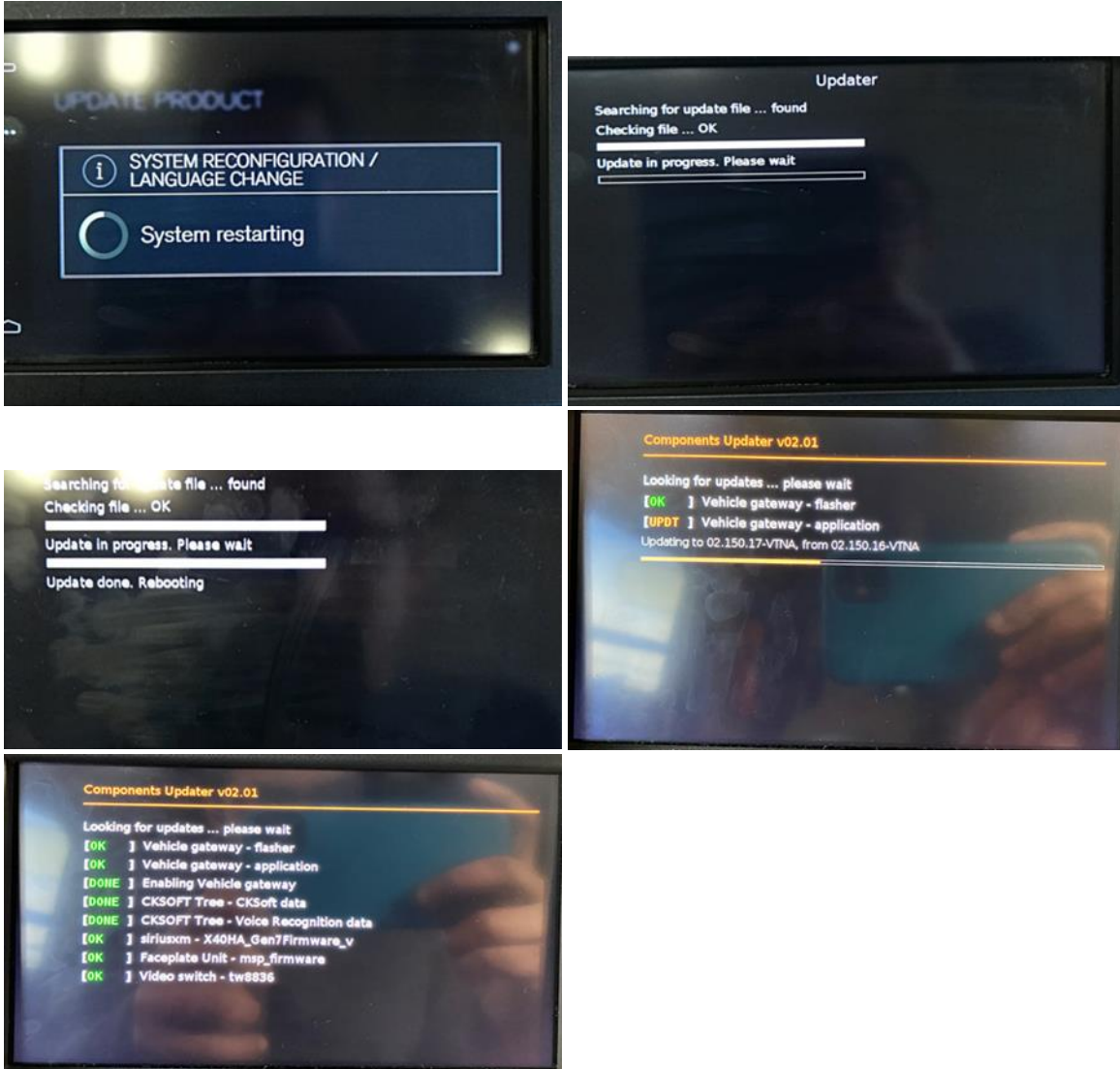

- The unit will automatically return to the Home Screen when the update is complete

## Update Voice Recognition and Navigation/Map Files Procedure

1. From the Home Screen, a Notification should be displayed. Select “Update” to start the process

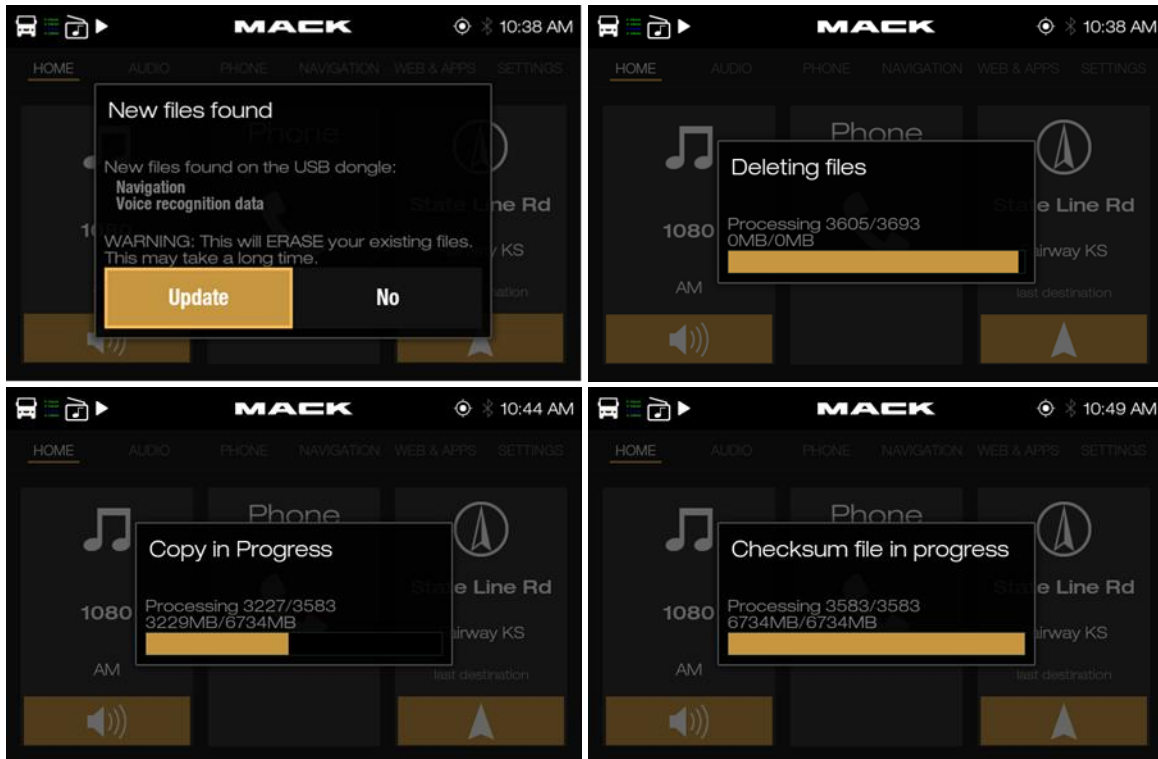

2. The unit will automatically return to the Home Screen

## Check the Update Versions

1. From the Home Screen, go to System Settings and select “About” to check the Software version matches 2.5.66.98

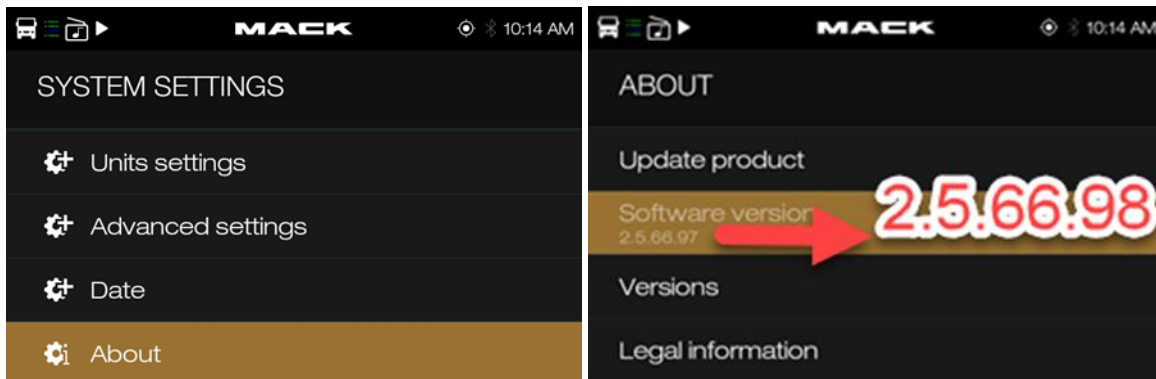

2. Select “Software version” and check that the voice recognition package versions are correct

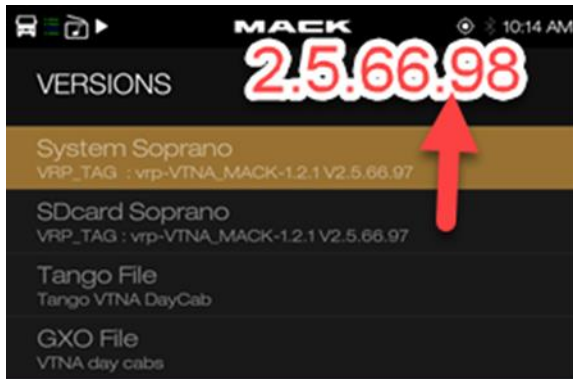

3. If the Infotainment unit has navigation, proceed to step 4.  
If the Infotainment unit does not have navigation, proceed to Commissioning the Truck for Operation on page 11.
4. Return to the Home Screen and select “Navigation”  
Note: If Navigation is unavailable, check that the correct USB stick is being used. Using an incorrect USB stick will remove navigation, and the steps in Software Update Procedure on page 6 will need to be performed again using the correct USB stick.

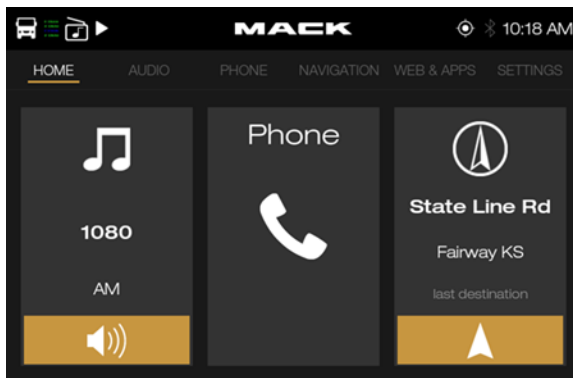

5. Select “...” then “?” then “About”

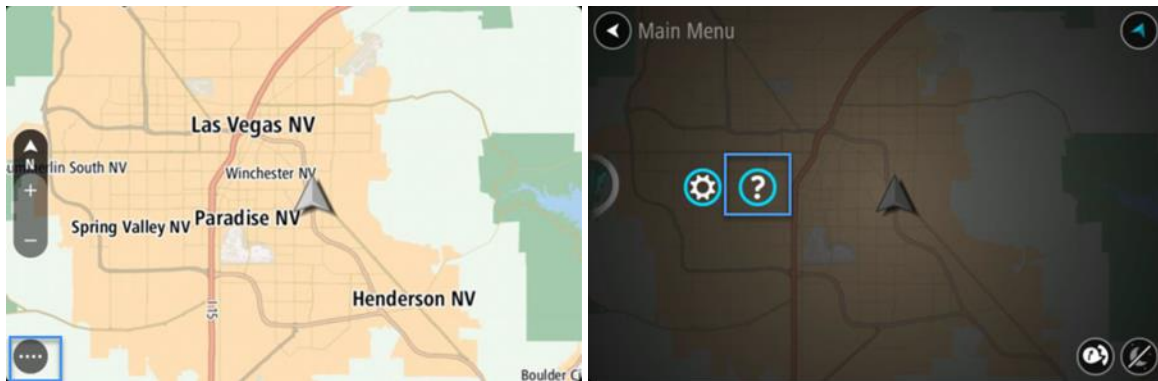

6. Check that the Installed Maps version is 1026.9453

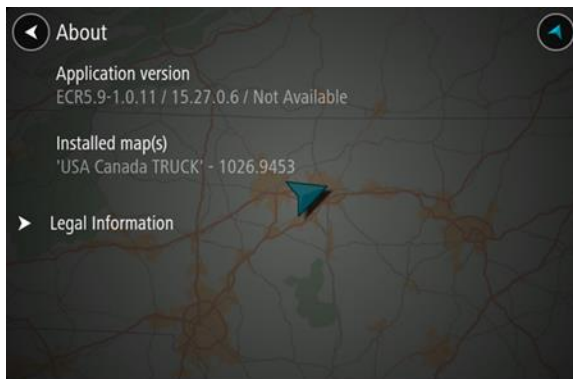

## Commissioning the Truck for Operation

1. Remove the USB stick from the dash



2. Remove the wheel chocks.

