

June 2020
SF605A

Subject: LED Step Lighting

Models Affected: Specific Model Years 2020-2021 Freightliner 108SD, 114SD, and Business Class M2 model vehicles, manufactured July 2, 2019, through February 25, 2020.

General Information

Daimler Trucks North America LLC (DTNA), on behalf of its Freightliner Trucks Division, is initiating Field Service Campaign SF605A to modify the vehicles mentioned above.

The frontwall harness that controls the LED step lighting is wired incorrectly.

The frontwall harness will be repinned.

There are approximately 264 vehicles involved.

Additional Repairs

Dealers must complete all outstanding Recall and Field Service campaigns prior to the sale or delivery of a vehicle. A Dealer will be liable for any progressive damage that results from its failure to complete campaigns before sale or delivery of a vehicle.

Owners may be liable for any progressive damage that results from failure to complete campaigns within a reasonable time after receiving notification.

Please contact Warranty Campaigns for consideration of additional charges prior to performing the repair.

Work Instructions

Please refer to the attached work instructions. Prior to performing the campaign, check the vehicle for a completion sticker (Form WAR261).

Replacement Parts

Replacement parts are now available and can be obtained by ordering the part number(s) listed below from your facing Parts Distribution Center.

If our records show your dealership has ordered any vehicle(s) involved in campaign number SF605, a list of the customers and vehicle identification numbers will be available on DTNAConnect. Please refer to this list when ordering parts for this campaign if needed.

Table 1 - Replacement Parts for SF605

Campaign Number	Part Number	Part Description	Part Number	Qty.
SF605A		MISCELLANEOUS SHRINK TUBES, CONNECTORS, AND WIRES		AS NEEDED
	WAR261	BLANK COMPLETION STICKER	WAR261	1 EA

Table 1

Removed Parts

U.S. and Canadian Dealers, please follow Warranty Failed Parts Tracking shipping instructions for the disposition of all removed parts. Export distributors, please destroy removed parts unless otherwise advised.

June 2020
SF605A

Labor Allowance

Table 2 - Labor Allowance

Campaign Number	Procedure	Time Allowed (hours)	SRT Code	Corrective Action
SF605A	Modify LED Step Light Wiring Harness	0.6	996-F069A	12-Repair Recall/Campaign

Table 2

IMPORTANT: When the campaign has been completed, locate the base completion label in the appropriate location on the vehicle, and attach the gray completion sticker provided in the field service kit (Form WAR261). If the vehicle does not have a base completion label, clean a spot on the appropriate location of the vehicle and first attach the base completion label (Form WAR259). If a field service kit is not required or there is no completion sticker in the kit, write the campaign number on a blank sticker and attach it to the base completion label.

Claims for Credit

You will be reimbursed for your parts, labor, and handling (landed cost for Export Distributors) by submitting your claim through the Warranty system within 30 days of completing this campaign. Please reference the following information in OWL:

- Claim type is **Field Service Campaign**.
- In the Campaign field, enter the campaign number and appropriate condition code (**SF605-A**).
- In the Primary Failed Part field, enter **25-SF605-000**.
- In the Parts section, it is not required to enter parts for this repair, but you may claim shop supplies up to a reasonable amount if appropriate.
- In the Labor section, enter the appropriate SRT from the Labor Allowance Table. Administrative time will be included automatically as SRT 939-6010A for 0.3 hours.
- The VMRS Component Code is **F99-999-005** and the Cause Code is **A1 - Campaign**.
- This Field Service Campaign will **terminate on June 30, 2021**. Dealers will be notified of any changes to the termination date via Important Campaign Information Letter posted on DTNAConnect.com.

IMPORTANT: OWL must be viewed prior to beginning work to ensure the vehicle is involved and the campaign has not previously been completed. Also, check for a completion sticker before beginning work.

All claims must be submitted within 30 days of the repair and within 30 days of the termination date of the campaign. U.S. and Canadian Dealers: All excess inventory to be returned to the PDC following the conclusion of the campaign must be returned in resaleable condition to the Memphis PDC within 90 days from the termination date. Please submit a PAR to request return to the Memphis PDC. (Canadian dealers should return the kits to their facing PDC.) Export Distributors: Excess inventory is not returnable.

For questions, U.S. and Canadian dealers, contact the Warranty Campaigns Department via Web inquiry at DTNAConnect.com/WSC, or the Customer Assistance Center at (800) 385-4357, if you have any questions or need additional information. Export distributors submit a Web inquiry or contact your International Service Manager.

June 2020
SF605A

Copy of Notice to Owners

Subject: LED Step Lighting

Daimler Trucks North America LLC (DTNA), on behalf of its Freightliner Trucks division, is initiating Field Service Campaign SF605A to modify specific Model Years 2020-2021 Freightliner 108SD, 114SD, and Business Class M2 model vehicles, manufactured July 2, 2019, through February 25, 2020.

The frontwall harness that controls the LED step lighting is wired incorrectly.

The frontwall harness will be repinned.

Please contact an authorized Daimler Trucks North America dealer to arrange to have the campaign performed and to ensure that parts are available at the dealership. To locate an authorized dealer, go to Daimler-TrucksNorthAmerica.com/Contact-Us/. Scroll down to "Locate a Dealer," and select the appropriate brand. The campaign will take approximately one hour and will be performed at no charge to you.

This Field Service Campaign will **terminate on June 30, 2021**. Please make sure the campaign is completed prior to this date. Work completed after this date will be done at the customer's expense.

As stated in the terms of your express limited warranty, Daimler Trucks North America LLC will not pay for any damage caused by failure to properly maintain your vehicle. Daimler Trucks North America LLC considers the work necessary under this campaign to be proper maintenance and will, therefore, not pay for any damage to your vehicle caused by your failure to have the repairs that are the subject of this campaign performed in a reasonable time.

Contact the Warranty Campaigns Department at (800) 547-0712, from 7 a.m. to 4 p.m. Pacific Time, Monday through Friday, e-mail address DTNA.Warranty.Campaigns@Daimler.com, or the Customer Assistance Center at (800) 385-4357, if you have any questions or need additional information.

WARRANTY CAMPAIGNS DEPARTMENT

Enclosure

June 2020
SF605A

Work Instructions

Subject: LED Step Lighting

Models Affected: Specific Model Years 2020-2021 Freightliner 108SD, 114SD, and Business Class M2 model vehicles manufactured July 2, 2019, through February 25, 2020.

LED Step Lighting Wiring Modification

1. Check the base label (Form WAR259) for a completion sticker for SF605 (Form WAR261) indicating this work has been done. The base label is usually located on the passenger-side door, about 12 inches (30 cm) below the door latch. If a sticker is present for SF605, no work is needed. If there is no sticker, proceed with the steps below.
2. Park the vehicle on a level surface, shut down the engine, and apply the parking brakes. Chock the tires.
3. Disconnect the battery negative cable.
4. Locate the 3-pin connector LT_DOME_FW_O_CHAS_F_STEP_LED_1A for the LED step light harness at the frontwall. The connector is located on the exterior frontwall near the left hood support. See **Fig. 1**.

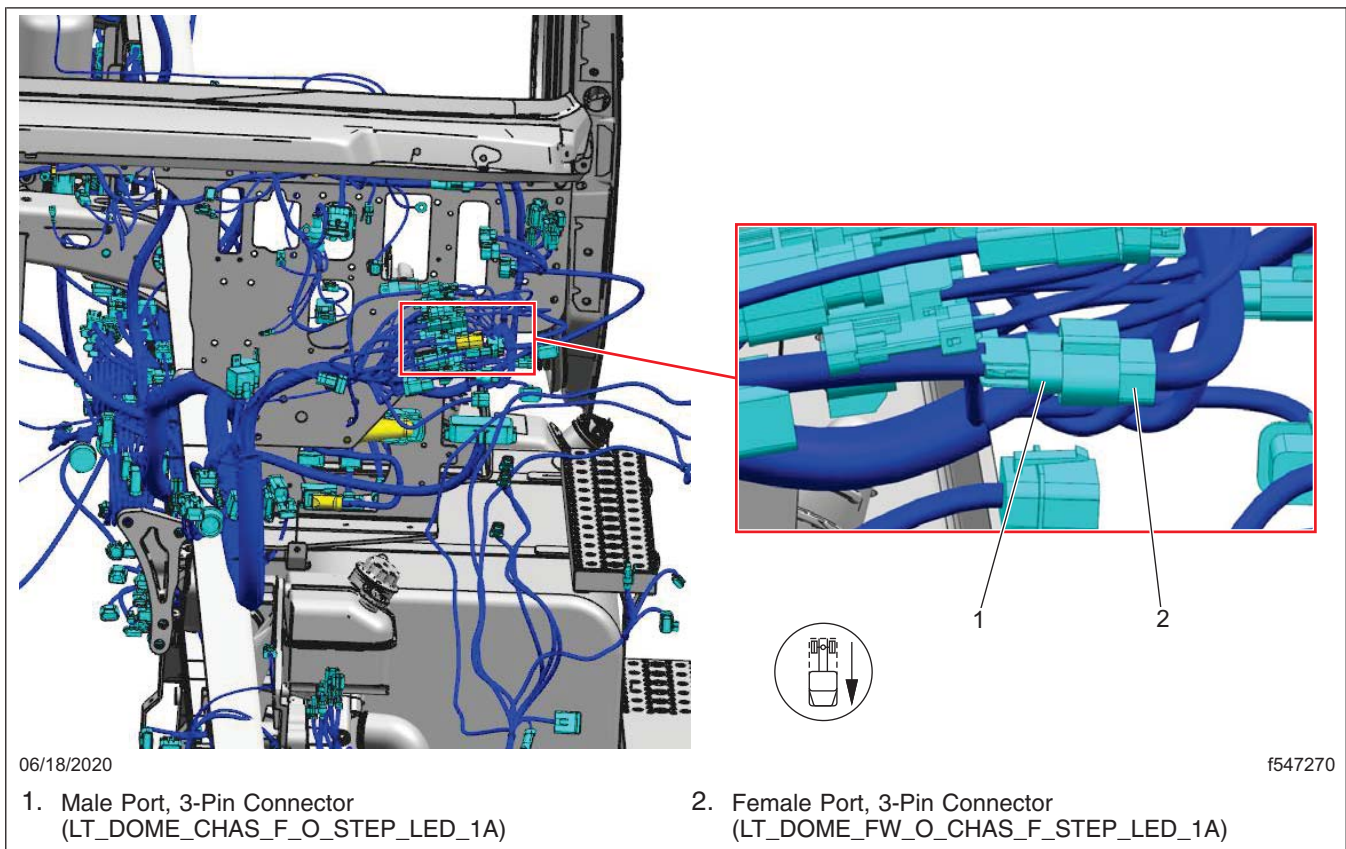

Fig. 1, 3-Pin Connector Location

June 2020
SF605A

5. On the frontwall side of the harness, remove the harness wrap and tape for about six inches to gain access to the wires within the LED step light harness at the 3-pin connector. The frontwall side of the harness connects to the 3-pin connector LT_DOME_FW_O_CHAS_F_STEP_LED_1A (P/N 23-13144-300) containing the female terminals. See [Fig. 1](#).
6. Locate the wires 108B and 109B at pin-B and pin-A of the 3-pin connector respectively. See [Fig. 2](#). Cut the two wires about four inches away from the 3-pin connector. Apply shrink tube on the frontwall harness side of each wire separately in order to seal/protect them and secure sealed wires into harness. The third wire in the 3-pin connector LT_DOME_FW_O_CHAS_F_STEP_LED_1A is the ground (GND) and will remain in the 3-pin connector pin-C.

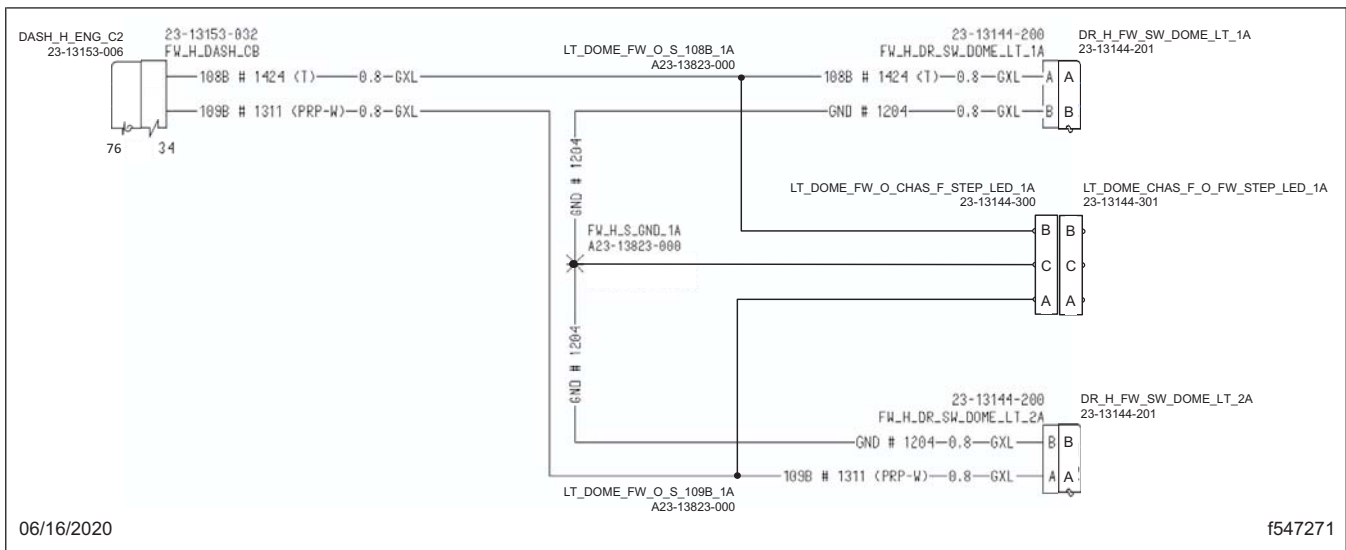

Fig. 2, Circuit Diagram, 3-Pin Connector

June 2020
SF605A

7. Using a butt connector, splice three feet of 16 gauge tan wire onto wires 108B and 109B from the 3-pin connector. See **Fig. 3**. Follow the instructions below.



Fig. 3, 3-Pin Connector after Splicing

- 7.1 Strip approximately 3/8-inch (1 cm) of insulation from wires 108B & 109B. Twist the two wires together. See **Fig. 4**.

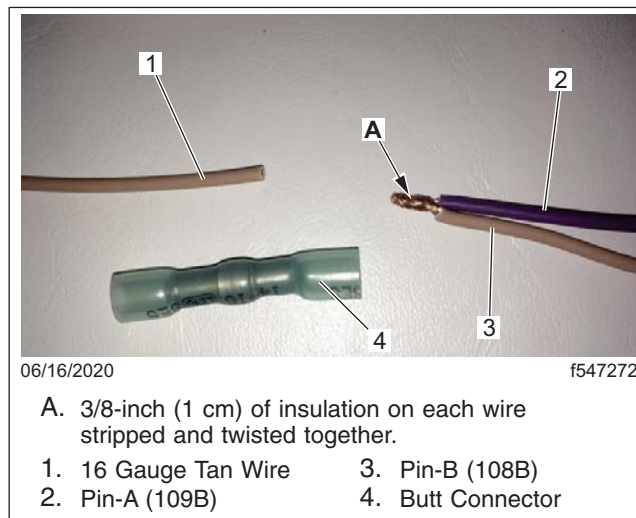

Fig. 4, 3/8-inch Wire Insulation Stripped and Twisted Together

June 2020
SF605A

- 7.2 Insert the twisted wires into the butt connector PHM 1 1862, then crimp using tool DKIOCHA17003-3. See [Fig. 5](#).
- 7.3 Strip approximately 3/4-inch (2 cm) of insulation from the new section of 16 gauge tan wire, then fold the stripped section of wire into half. See [Fig. 5](#)

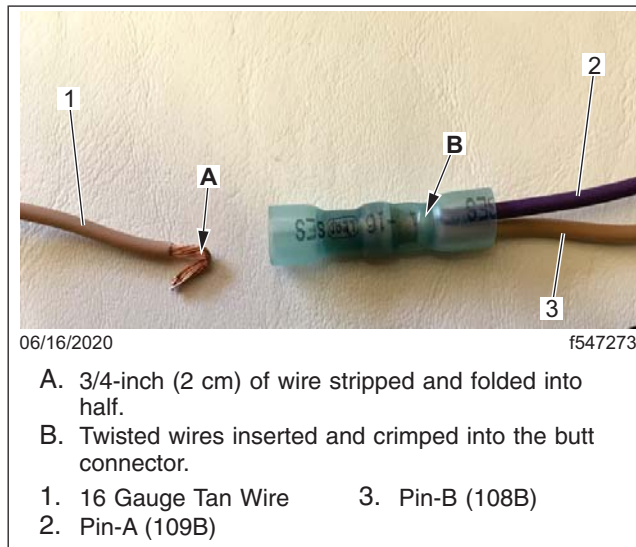

Fig. 5, Crimping Wires into Butt Connector.

- 7.4 Insert the folded wire into the butt connector, then crimp using tool DKIOCHA17003-3.
- 7.5 Using a heat gun, carefully heat shrink the butt connector. See [Fig. 6](#).



Fig. 6, Butt Connector Heat Shrunk

June 2020
SF605A

IMPORTANT: The new section of 16 gauge tan wire should be spliced into wire 108C, and routed along the frontwall via harness A06-67182-000 to be accessible at the 4-pin connector FW_OVLY_H_LH_DR_C1.

8. Locate the 4-pin connector FW_OVLY_H_LH_DR_C1 on the exterior frontwall near the left hood support, which connects to the left door harness near the upper outside edge of the cab frontwall.
See **Fig. 7** and **Fig. 8**.

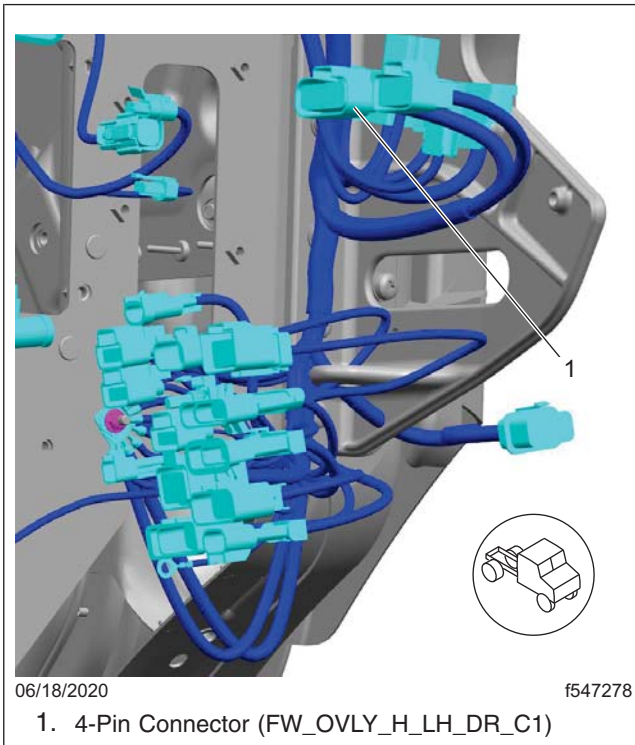

Fig. 7, 4-Pin Connector Location

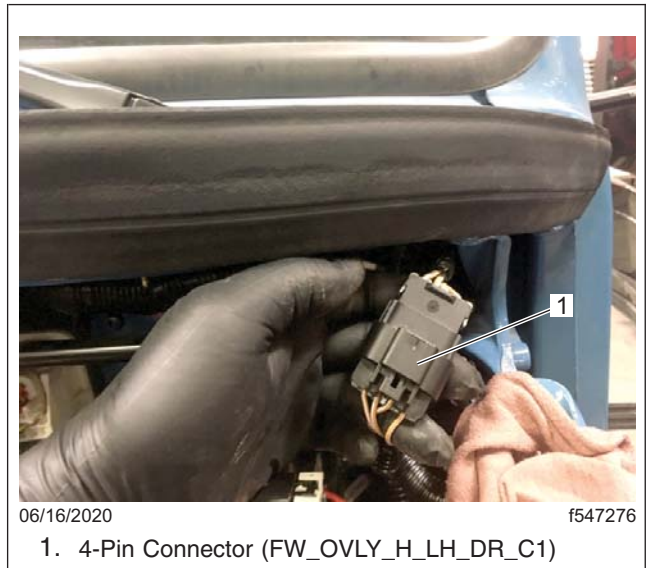

Fig. 8, 4-Pin Connector

June 2020
SF605A

9. To access the wires within the A06-67182-000 harness at the 4-pin connector FW_OVLY_H_LH_DR_C1, remove approximately six inches of harness wrap and tape on the frontwall side of the harness. Locate the tan wire (108C). See Fig. 9 for circuit diagram of the 4-pin connector FW_OVLY_H_LH_DR_C1.

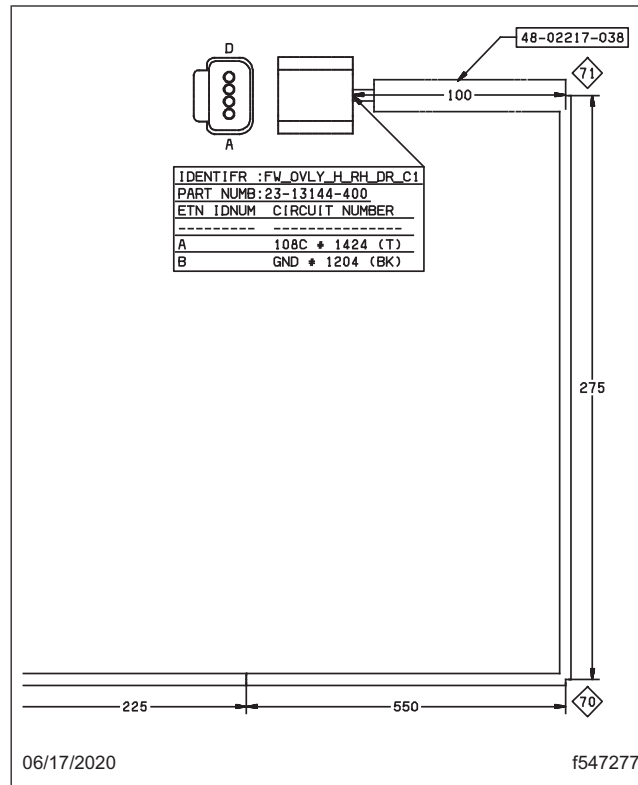

Fig. 9, Circuit Diagram, 4-Pin Connector

10. Cut the tan wire (108C) about four inches from connector FW_OVLY_H_LH_DR_C1. Using a butt connector, splice the new section of 16 gauge tan wire from the 3-pin connector into wire 108C of the 4-pin connector as follows:
 - 10.1 Strip approximately 3/8-inch (1 cm) of insulation from the cut frontwall harness side of the wire 108C and the tan wire from the 3-pin connector. Twist the two wires together. See Fig. 4.
 - 10.2 Insert the twisted wires into the butt connector PHM 1 1862, then crimp using tool DKIOCHA17003-3. See Fig. 5.
 - 10.3 Strip approximately 3/4-inch (2 cm) of insulation from the cut wire (108C) that is connected to the 4-pin connector, and then fold the stripped section of wire into half. See Fig. 5.
 - 10.4 Insert the folded wire into the butt connector, then crimp using tool DKIOCHA17003-3.
 - 10.5 Using a heat gun, carefully heat shrink the butt connector. See Fig. 6.
11. Connect the negative battery cable.

June 2020
SF605A

12. Test the operation of the LED step light provision wiring at the left front under-cab area (under the driver's side floor), and at the right inner frame rail near the aftertreatment system (ATS) for the output below.
See [Fig. 10](#) and [Fig. 11](#).

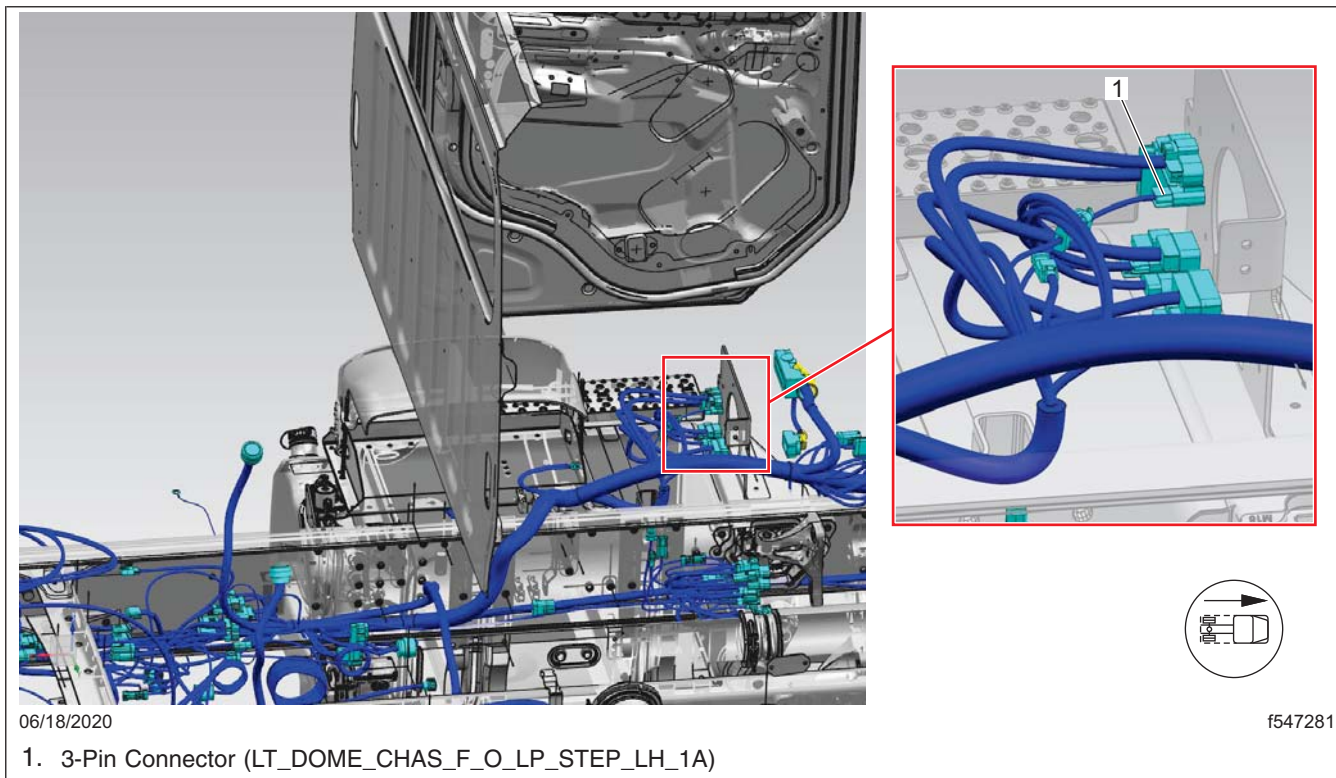

Fig. 10, LED Step Light Provision Wiring, LH

June 2020
SF605A

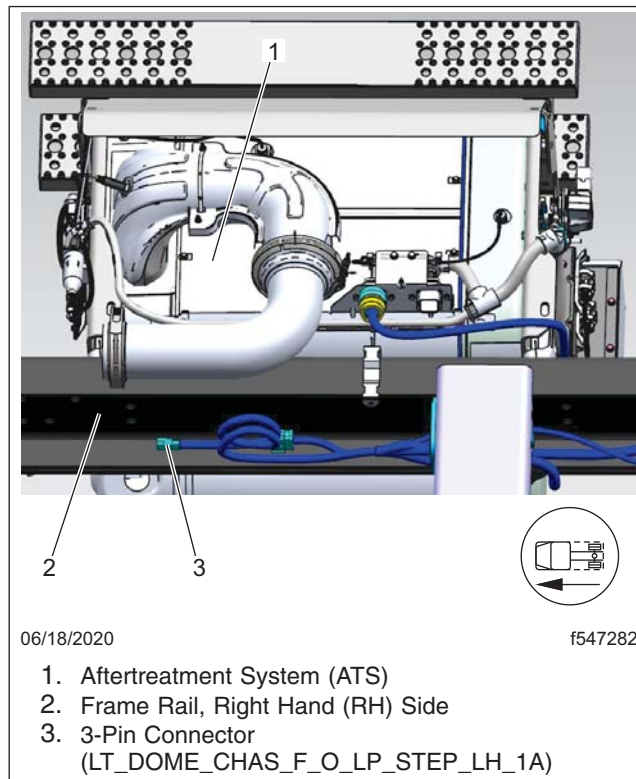

Fig. 11, LED Step Light Provision Wiring, RH

- Power should be present at each LED step connector when the driver or passenger door is open.
 - Power should not be present when the driver and passenger doors are both closed.
13. Wrap previously exposed harness wires, and the new section of the 16 gauge tan wire with appropriate side harness wrap.
 14. As needed, secure the harnesses and wires using tie straps and electrical tape.
 15. Clean a spot on the base label (Form WAR259) and attach a campaign completion sticker for SF605 (Form WAR261) indicating this work has been completed.