

# PREVOST

## MAINTENANCE INFORMATION

**MI20-11**

DATE :	June 2020	SECTION :	23 ACCESSORIES
SUBJECT :	<b>PREVOST DRIVER ASSIST™ System description</b>		

First Release

06-19-20

<b>PREVOST DRIVER ASSIST™</b> .....	<b>3</b>
ASSOCIATED HARDWARE/EQUIPMENT .....	3
PREVOST DRIVER ASSIST™ CONSISTS OF THE FOLLOWING SYSTEMS AND FEATURES.....	4
POTENTIALLY CHALLENGING SITUATIONS FOR THE PREVOST DRIVER ASSIST™ SYSTEM .....	6
LANE DEPARTURE WARNING LDW .....	7
<i>LDW activation</i> .....	7
<i>Temporarily Disabling the Lane Departure Warning (LDW)</i> .....	7
<i>LDW Status line Pictograms Description</i> .....	7
<i>LDW Popup Messages Definition</i> .....	8
FORWARD COLLISION MITIGATION FCM.....	11
<i>Stationary vehicle braking SVB</i> .....	11
<i>Head-Up Display HUD</i> .....	12
ADAPTIVE CRUISE WITH BRAKING ACB.....	13
<i>Turning the ACB System On</i> .....	13
<i>Turning off the ACB system</i> .....	14
<i>Maintaining a Set Following Distance</i> .....	14
<i>Driver Warnings</i> .....	15
<i>Dashboard Telltale</i> .....	15
<i>Speedometer Leds</i> .....	15
<i>Following Distance Alert (FDA)</i> .....	16
<i>Impact Alert (IA)</i> .....	17
<i>Brake Overuse Warning</i> .....	17
<i>Self-Diagnostic at Start-Up</i> .....	19
<i>System Malfunction</i> .....	19
WHAT TO EXPECT WHEN USING THE PREVOST DRIVER ASSIST™ SYSTEM.....	20
HOW YOUR ACTIONS IMPACT THE PREVOST DRIVER ASSIST™ SYSTEM .....	24



## PREVOST DRIVER ASSIST™

Prevost Driver Assist™ provides what is commonly known in the automotive industry as Advanced Driver Assistance Systems (ADAS). ADAS are meant to assist but not replace the driver. ADAS must be monitored at all times.



### WARNING

Even with Prevost Driver Assist™ system, the driver must remain alert, react appropriately and in a timely manner, and use good driving practices. Ultimate responsibility for the safe operation of the vehicle remains with the driver at all times.

Be certain that you have read all safety warnings found in **Bendix Wingman Fusion Operator's Manual BW2681** available on Prevost Technical Publications site or your Technical Publications USB key.

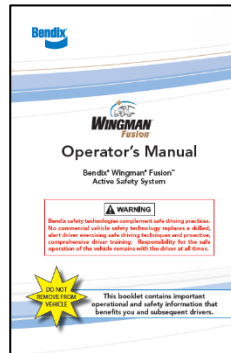

## ASSOCIATED HARDWARE/EQUIPMENT

- FLR-21 radar sensor (ACB)
- Head-up display (HUD)
- Lane Departure Warning System (LDW) enable/disable switch
- FLC-20 windshield forward-looking camera (LDW)
- Bendix ESP EC-80 Controller
- Instrument panel DID (telltale and warning popups)

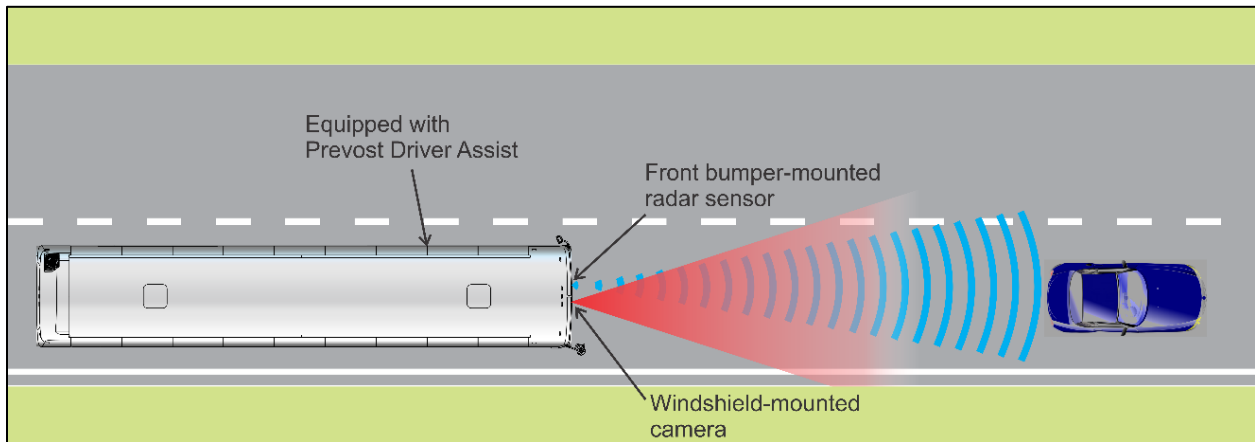

FIGURE 1: PREVOST DRIVER ASSIST™ SYSTEM USES A CAMERA AND RADAR SENSOR

## PREVOST DRIVER ASSIST™ CONSISTS OF THE FOLLOWING SYSTEMS AND FEATURES

DRIVING CONTROL ASSISTANCE	
Adaptive Cruise with Braking ACB	Assists with acceleration and/or braking to maintain a prescribed distance between your vehicle and the vehicle ahead in your lane of travel. <ul style="list-style-type: none"> <li>• FDA Following Distance Alert</li> <li>• IA Impact Alert</li> </ul>
COLLISION WARNINGS	
Lane Departure Warning LDW	Alerts the driver as the vehicle unintentionally approaches or crosses lane markers.
Head-Up Display HUD	Projects a visual forward collision warning into the driver's forward line of sight.
COLLISION INTERVENTION	
Forward Collision Mitigation FCM	Detects potential collision with stationary or moving vehicles in the lane ahead while the vehicle is traveling forward, provides forward collision warning and automatically applies the brakes to lessen the severity of an impact. <ul style="list-style-type: none"> <li>• SVB Stationary vehicle braking</li> </ul>

FEATURES	ACTIVE EVEN IF ACB IS OFF OR CRUISE SPEED NOT SET
FDA Following Distance Alert (warnings only)	Yes If speed above 36 mph (58 km/h)
IA Impact Alert (warnings only)	Yes If speed above 15 mph (24 km/h)
LDW Lane Departure Warning	Yes If speed above 36 mph (58 km/h)
FCM Forward Collision Mitigation (including SVB Stationary Vehicle Braking) (warnings & braking)	Yes If speed above 15 mph (24 km/h)

## WARNING

The Prevost Driver Assist™ system reacts **ONLY** to vehicles that are **stationary or moving in the same direction as your vehicle**.

The Prevost Driver Assist™ system **DOES NOT** respond to side-to-side moving traffic, or oncoming traffic. The system will not slow your vehicle or provide an alert as you approach vehicles in these circumstances.

The system does not brake nor warn for vehicles approaching from the side or oncoming

## POTENTIALLY CHALLENGING SITUATIONS FOR THE PREVOST DRIVER ASSIST™ SYSTEM

The following examples illustrate situations that may issue an alert or braking in a manner not consistent with your expectations. The Prevost Driver Assist™ system may unexpectedly issue warnings, apply braking, or not respond.

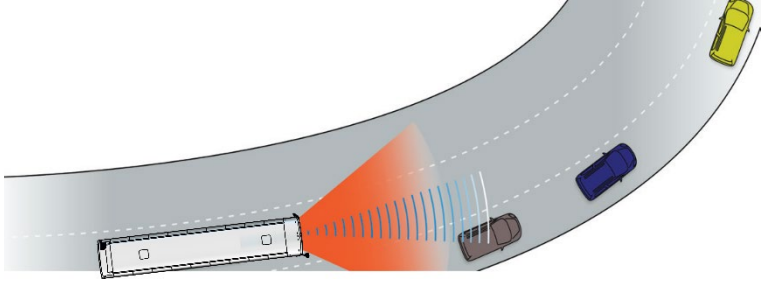
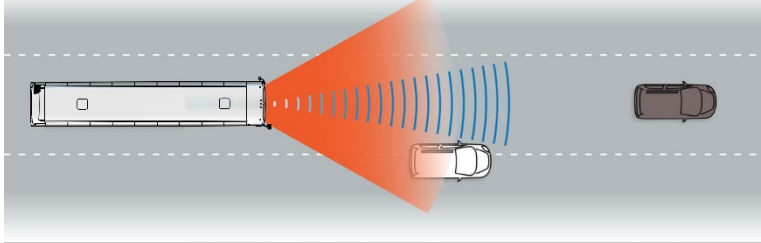
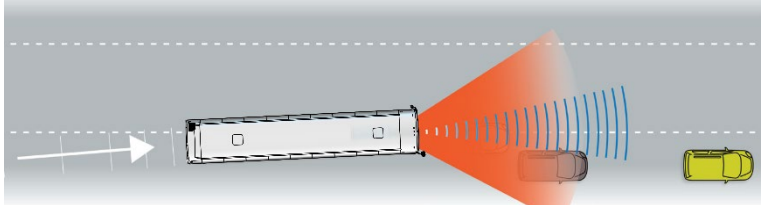
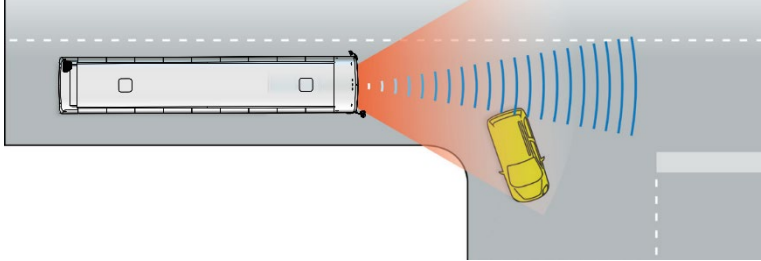
CHALLENGING SITUATION EXAMPLES	
	Driving through a curve or an exit ramp
	Other vehicles partially inside your lane of travel
	Lane changes
	Turning vehicles

## LANE DEPARTURE WARNING LDW

Using the FLC-20 windshield forward-looking camera, the Lane Departure Warning system (LDW) monitors the vehicle position in its lane and alerts the driver as the vehicle unintentionally approaches or crosses lane markers thru audible and visual warnings. **The driver should immediately correct the vehicle tracking and maintain position in the lane.**

When changing lanes, the driver must use the turn signals.

### LDW activation

The Lane Departure Warning system is active whenever the vehicle is traveling above 36 mph (58 km/h). LDW is active no matter if the ACB is OFF or speed not set.

### Temporarily Disabling the Lane Departure Warning (LDW)



To avoid erroneous LDW warnings in areas such as the work zone where the road markings present might cause false alerts, LDW system can be disabled by the driver using the enable/disable switch. LDW system will reactivate automatically after a delay of 15 minutes or a transition from OFF to ON of the ignition key or upon pressing of the enable/disable switch a second time.



LDW ENABLE/DISABLE SWITCH

### LDW Status line Pictograms Description



The following pictograms appear in the DID status line to confirm that the system is active and currently tracking the driving lane.





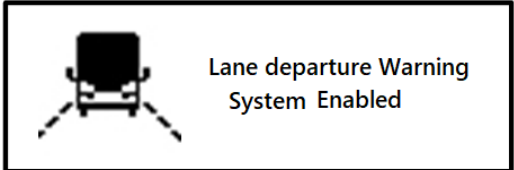
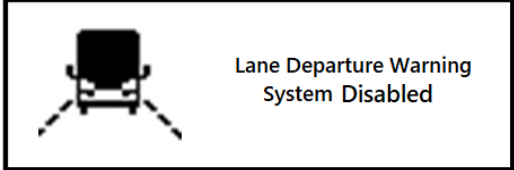

PICTOGRAM	DESCRIPTION
	Actively tracking lane markings on both sides of current lane
	Currently tracking lane marking on the left side only
	Currently tracking lane marking on the right side only



The following pictogram appears in the DID status line to warn that the system IS NOT currently tracking the driving lane.

PICTOGRAM	DESCRIPTION
	LDW system initializing during the start-up or tracking not available
none	If none of the LDW status pictograms appear on the DID status line and the driver has not pressed the LDW enable/disable switch, this indicates that the system using the FLC-20 forward-looking camera has detected a DTC (diagnostic troubleshooting code) and the system should be serviced at the earliest opportunity.

### LDW Popup Messages Definition

POPUP MESSAGE	DESCRIPTION/AUDIBLE ALARM
	LDW system enabled – the LDW system is currently tracking the driving lane.
	LDW system disabled – the LDW system IS NOT currently tracking the driving lane.
	The vehicle is about to cross the right lane marker.  <i>audible warning: TOK – TOK</i>
	The vehicle is about to cross the left lane marker.  <i>audible warning: TOK – TOK</i>

 <p><b>Malfunction Forward Imager</b></p>	<p>Indicates a malfunction of the forward-looking camera. The LDW system tracking might be disabled or not reliable.</p> <p>The driver can acknowledge and turn off this popup message using Esc (escape) button on the steering wheel.</p>
 <p><b>Malfunction Check camera for obstructions</b></p>	<p>Indicates a malfunction of the LDW system camera. The LDW system tracking might be disabled or not reliable.</p> <p>Stop the vehicle and check if something is obstructing the camera.</p> <p>The driver can acknowledge and turn off this popup message using Esc (escape) button on the steering wheel.</p>
 <p><b>Malfunction Brake Switch</b></p>	<p>Indicates a malfunction of the LDW system brake switch. The LDW system tracking might be disabled or not reliable.</p> <p>The driver can acknowledge and turn off this popup message using Esc (escape) button on the steering wheel.</p>
 <p><b>Malfunction Turn Signal</b></p>	<p>Indicates a malfunction of the directional turn signals. The driver can acknowledge and turn off this popup message using Esc (escape) button on the steering wheel.</p>
 <p><b>Input switch stuck low</b></p>	<p>Indicates a malfunction of the LDW system input switch.</p> <p>The driver can acknowledge and turn off this popup message using Esc (escape) button on the steering wheel.</p>
 <p><b>Network Error</b></p>	<p>Indicates a loss of communication on the vehicle data network. The LDW system tracking might be disabled or not reliable.</p> <p>The driver can acknowledge and turn off this popup message using Esc (escape) button on the steering wheel.</p>

 <p><b>Unknown Vehicle Speed</b></p>	<p>Indicates the current vehicle speed is unknown. The LDW system tracking might be disabled or not reliable.</p> <p>The driver can acknowledge and turn off this popup message using Esc (escape) button on the steering wheel.</p>
 <p><b>Lane Departure Warning System Malfunction</b></p>	<p>Indicates a malfunction of the LDW system. The LDW system tracking is not available.</p>

## FORWARD COLLISION MITIGATION FCM

The Forward Collision Mitigation system (FCM) detects potential collisions while the vehicle is traveling forward, provides warnings to the driver and when needed, automatically applies up to 66% of the braking power to lessen the severity of an impact.

The FCM system is ready to intervene whenever the vehicle is traveling at speed above 15 mph (24 km/h). It operates independently of the vehicle ACB and will intervene even if the cruise control is turned off or there is no cruise set speed.

The FCM system is enhanced with the use of the FLC-20 windshield forward-looking camera. This camera increases the performance of the collision mitigation system by visually detecting a forward object as a vehicle and confirming with the ACB radar sensor its position within the lane of travel. With this increased object recognition capability, the system is able to detect stationary vehicles.

If the forward vehicle is stationary, the FCM system will apply up to 66% of the braking power. The maximum speed reduction is about 25 mph / 40 km/h. Note that this feature will not bring the vehicle to a complete stop.

### Stationary vehicle braking SVB.

SVB typically available above 15 mph (24 km/h). As part of the collision mitigation system, when a large, stationary, metallic object in a vehicle's lane of travel is definitively identified as a vehicle (thru FLC-20 camera), the driver is notified up to 3.5 seconds before impact. If the driver does not take action to address the potential impact that caused the alert, the FCM system can automatically engage the brakes to assist the driver in reducing the severity or potentially avoiding a collision with that stationary vehicle.

If the system cannot definitively identify the stationary object as a vehicle — for example, if the vehicle is not a licensed motorized vehicle, or certain types of trailers — the driver will get up to 3.0 seconds of alert to address the situation ahead, but no automatic braking will be applied. SVB is most useful when approaching a line of stopped traffic or a stalled vehicle that is not immediately recognized by the driver.

The SVB is ready to alert the driver whenever the vehicle is moving above 15 mph (24 km/h). The driver should be especially careful when approaching certain types of vehicles or objects. The system radar sensor may not be able to detect vehicles with limited metal surfaces (such as recreational vehicles, horse-drawn buggies, motorcycles, logging trailers, etc.). NOTE: Entering a curve may reduce the alert time.



### CAUTION

#### **Pedestrians, Animals, Non-metallic, or Limited-metallic Objects**

The Prevost Driver Assist™ system will not warn or react to pedestrians, animals, and non-metallic objects. The system may not warn or react to limited-metallic objects (such as recreational vehicles, horse-drawn buggies, motorcycles, logging trailers, etc.).

## Head-Up Display HUD

The FCM system is enhanced with a Head-Up Display (HUD) LED warning. The HUD project an intensive red light that is reflected in the windscreen to warn the driver when the FCM detects potential collision.

HUD Diagnostic: At startup, the HUD warning LED shall be diagnosed for failures such as open circuit, short to battery and short to ground. This shall be performed by activating the LED for a short time.

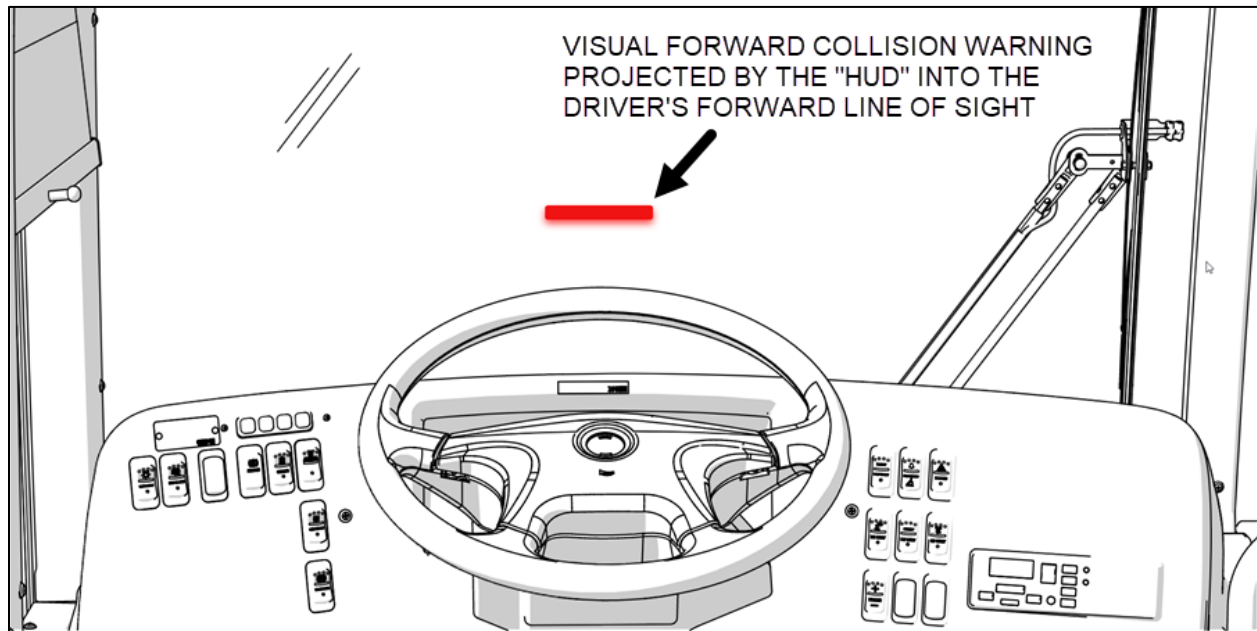

FIGURE 2: HEAD-UP DISPLAY PROJECTED VISUAL WARNING

## ADAPTIVE CRUISE WITH BRAKING ACB

Adaptive Cruise with Braking (ACB) is a cruise control that not only maintains the set speed, but will also intervene, as needed, to help the driver maintain a set following distance behind a detected forward vehicle by reducing speed as necessary. As soon as the forward vehicle is at a safe distance, the coach will resume to the cruise set speed.

### NOTE

*The following paragraphs briefly sum up the information concerning the operation and function of the ACB. Before driving the vehicle, be certain that you have read and that you fully understand each step of the driving and handling information found in Bendix Wingman Fusion Operator's Manual BW2681. The driver should fully understand all the audible alerts and visual indicators that the system provides. Bendix Wingman Fusion Operator's Manual BW2681 (available on Prevest web site and included on the Technical Publications USB key).*



### WARNING

Even with ACB, the driver must remain alert, react appropriately and in a timely manner, and use good driving practices. Ultimate responsibility for the safe operation of the vehicle remains with the driver at all times.

Be certain that you have read all safety warnings found in Bendix Wingman Fusion Operator's Manual BW2681.

The driver will benefit all the audible and visual warnings that the system provides whether or not ACB is turned on. In addition to the audible and visual warnings, when the ACB is turned on and a **cruise speed is set**, the driver benefits from active interventions like engine throttle reduction, retarder or engine brake application and service brake application **to help maintain a set following distance**.



### WARNING

Adaptive Cruise with Braking must be used only in the same conditions that are normally recommended for ordinary cruise control. Refer to "Regular Cruise Control" paragraph.

## Turning the ACB System On

Activation of the Adaptive Cruise with Braking is similar to the regular cruise control activation. Press the CRUISE rocker switch to the ON position, accelerate the vehicle to the desired cruising speed and then, press the SET button. ACB is now engaged with the set following distance and driver warning features. Whenever the cruise control is engaged, the ACB is also engaged. You cannot engage the cruise control alone, without engaging the ACB features.

## Turning off the ACB system

You can turn off the ACB system, simply by applying service brakes, setting the CRUISE rocker switch to the OFF position or pressing the cruise control CANCEL button on the steering wheel.

### **NOTE**

*Whenever the service brakes are applied by intervention of the ACB or by the driver, normal cruise will automatically be canceled. The driver must resume or set the cruise mode in order for the vehicle to throttle up.*

## Maintaining a Set Following Distance

Using a radar sensor mounted to the front bumper, the ACB system measures the distance between the coach and the forward vehicle and intervenes to help maintain a safe set following distance behind the vehicle. This feature engages automatically once the driver turns on and sets cruise speed.

Following distance refers to the time gap, measured in seconds, between the coach and the vehicle ahead. The actual physical distance between the coach and the vehicle ahead will vary based on your set cruise speed; although the set time gap remains the same for all set cruise speeds. Prevost's default set time gap is 1.7 seconds.

With cruise control engaged and a cruise speed set, you are maintaining a set following distance behind the vehicle in front of you (The system DOES NOT respond to side-to-side moving traffic or oncoming traffic.)

**If the vehicle in front of the coach slows down** below your cruise control set speed, the system will progressively intervene as follows, in this order:

1. Reduce the engine throttle;
2. Apply the engine brake or transmission retarder;
3. Apply about 30% of the service brakes available braking power in an attempt to maintain the set following distance.

The driver must apply additional braking power when required, to avoid collision or to maintain a safe distance from the vehicle ahead.

### **NOTE**

*If the ACB is actively decelerating or braking the coach in an attempt to maintain the set following distance at the moment when the driver cancels the ACB system, the ACB system will continue deceleration or braking intervention until a safe following distance is established, then will cancel.*

*Even though the cruise control doesn't operate at speeds below 30 mph / 50 km/h, the ACB system will continue deceleration or braking intervention in an attempt to maintain the set following distance if the coach speed reduces to less than 30 mph / 50 km/h.*

**If the vehicle ahead slows below your cruise control's set speed**, but then accelerates away, and the ACB system did not need to use the service brakes as it managed the intervention, the

coach will automatically accelerate back to the original cruise control set speed, and again maintain a set following distance behind the forward vehicle.

**NOTE**

*The maximum radar range is approximately 500 feet (150 meters). Rain, snow, fog, ice and other severe weather conditions may affect the performance of the ACB system and shorten radar range.*



*As part of your pre-trip vehicle inspection, check to see that there is no mud, snow, ice build-up or other obstruction in front of the radar sensor. You should inspect the radar sensor mounting and remove any obstruction that may impair the sensor functioning.*

**Driver Warnings**

Before using the ACB, the driver should fully understand all the audible and visual warnings that the system provides. Any audible warning (beeping or tone) means that your vehicle is too close to the vehicle ahead.

**Dashboard Telltale**

When ACB is turned on and a cruise speed is set, if the forward vehicle is detected (in range) by the radar, the FORWARD VEHICLE DETECTED telltale light will illuminate. This is an indication to the driver that the forward vehicle is being tracked, that the ACB is actively managing the distance between the coach and the vehicle ahead and that the ACB system may automatically intervene to maintain the set following distance. There are three types of warnings with this telltale light.

FORWARD VEHICLE DETECTED telltale light	COLOR	DESCRIPTION
	green	The forward vehicle is detected (in range)
	red flashing	<b>Impact alert.</b> The forward vehicle is too close to follow safely or a metallic stationary object such as a stopped or stalled vehicle in your lane of travel is detected. The driver must intervene to avoid a collision.
	red solid	ACB system malfunction. The ACB system and the alert functions are not available.

**Speedometer LEDS**

With the cruise control engaged and a cruise speed set, a green LED illuminates above the cruise control set speed on the speedometer.

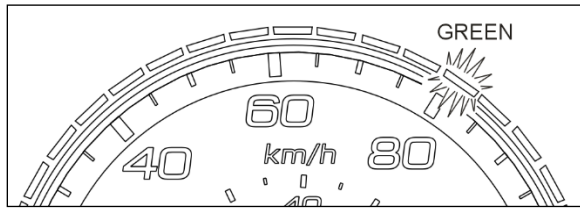

**THE CRUISE SET SPEED IS 80 km/h**

With a cruise speed set, the vehicle ahead slows moderately. The system will display to the driver the approximate speed of the vehicle ahead with yellow LEDs above the speedometer.

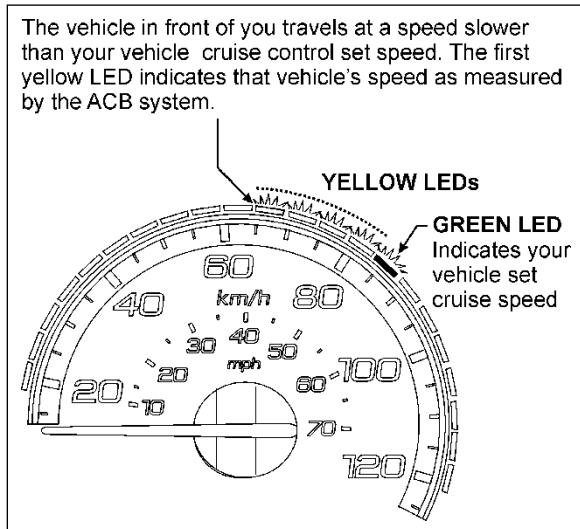

**EXAMPLE OF THE SPEEDOMETER LED DISPLAY WHEN THE FORWARD VEHICLE IS SLOWER WHILE THE COACH TRAVELS WITH THE ACB CRUISE CONTROL ON AND SET**  
06729\_3

### Following Distance Alert (FDA)

Following Distance Alert is always active whenever the coach is moving to a speed greater than 36 mph (58 km/h), whether or not ACB is turned on.

Following Distance Alert provides both audible and visual warnings whenever the distance between the coach and the forward vehicle is less than the set distance and getting closer. Once the audible warning is given, the driver must increase the distance between the coach and the vehicle ahead until the audible warning stops or maneuver clear of the forward vehicle.

 <b>WARNING</b>
Active interventions of ACB to maintain safe following distance (throttle reduction, engine brake/retarder application, service brakes application) are only operational when the ACB is engaged with a cruise speed set.

## Impact Alert (IA)

Impact Alerts are always operational when the vehicle is moving above 15 mph (24 km/h) whether or not ACB is turned on.

The Impact Alert warning is the most severe warning issued by the ACB system. This alert indicates that the driver must take immediate evasive action by applying more braking power and/or steering clear of the vehicle ahead to potentially avoid or lessen the severity of a collision. **Collision Mitigation Braking CMB** applies vehicle braking to help avoid or lessen the severity of a collision with a forward vehicle.

The Impact Alert is also applicable to stationary metallic objects such as stopped or stalled vehicles. This alert provides a warning given up to 3.0 seconds before a potential collision with a stationary metallic object in the coach's lane of travel. The driver can either slow down or maneuver in an attempt to avoid the object.

The Impact Alert will only warn and will not actively decelerate or brake the coach when approaching stationary objects.



### WARNING



Active interventions of ACB to maintain safe following distance (throttle reduction, engine brake/retarder application, service brakes application) are only operational when the ACB is engaged with a cruise speed set.

## Brake Overuse Warning

ACB provides a warning when the system is intervening and using the service brakes excessively. Overuse of the foundation brakes can lead to the brakes overheating and a potential loss of braking performance from brake fade. For example, the use of ACB on downhill runs may cause this alert to be activated. It is recommended that ACB be disengaged on downhill grades. The driver should use appropriate gearing and brake techniques, and not rely on ACB, on downhill grades.

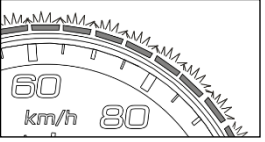
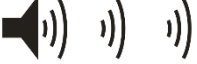
If the driver does not respond to the Brake Overuse Warning after a brief delay, the ACB will switch off.

<b>FOLLOWING DISTANCE ALERT</b>	
<b>CONDITION</b>	The Following Distance Alert feature is only available when the coach speed is greater than 36 mph (58 km/h) whether or not ACB is engaged. The forward vehicle is slowing down and the distance between your vehicle the coach and the forward vehicle is less than the set distance.
<b>ACTIONS BY ACB SYSTEM</b>	<p>“Distance Alert” popup message appears on the DID</p>  <p>The speedometer LEDs illuminate in <b>red</b></p>  <p>If the vehicles remain too close from each other for more than 15 seconds, an audible warning will sound (<b>beeping</b>)</p> 

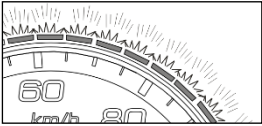
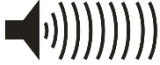
<b>IMPACT ALERT</b>	
<b>SITUATION</b>	ACB system detects a risk of collision with a forward-moving vehicle or a stationary metallic object in your lane of travel.
<b>ACTIONS BY ACB SYSTEM</b>	<p>On the dashboard, the Forward Vehicle Detected telltale <b>flashes</b> in <b>red</b></p>  <p>“Impact Alert” popup message appears on the DID</p>  <p>The speedometer LEDs <b>flash</b> in <b>red</b></p>  <p>An audible warning will sound (<b>continuous modulating tone</b>)</p> 

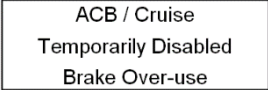
<b>BRAKE OVERUSE WARNING</b>	
<b>SITUATION</b>	ACB system is using the service brakes excessively to maintain the set following distance (for example, the use of ACB on long, steep downhill runs). Excessive application of the service brakes can cause the brakes to overheat resulting in increasing stopping distances.
<b>ACTIONS BY ACB SYSTEM</b>	<p>After a brief delay, the ACB system will stop functioning and be disabled.</p> <p>On the dashboard, the Forward Vehicle Detected telltale <b>illuminates</b> in <b>red</b></p>  <p>“ACB/Cruise Temporarily Disabled Brake Overuse” popup message appears on the DID</p> 

“ACB Not Available” pictogram appears on the DID status line 

### Self-Diagnostic at Start-Up

Initiate the self-diagnostic as follows:

The engine must be running since at least 15 seconds with the parking brake applied.

Trip the CRUISE rocker switch located on the lateral control panel from OFF to ON position.

The following sequence will begin:

1. Popup message “Impact Alert” will show in the DID;
2. The speedometer LEDs will flash in red;
3. FORWARD VEHICLE DETECTED telltale will flash in red;
4. The Impact Alert audible alarm will sound.

At the end of the self-diagnostic sequence, popup message « ACB SELF-CHECK OK » will show on the DID if the system functions properly or « ACB SELF-CHECK NOT OK » if a fault condition is detected.



### System Malfunction

In case of system malfunction, visual warnings will illuminate in the instrument cluster or the driver information display to warn the driver that the ACB is disabled. In that situation, the Impact Alert and Distance Alert functions are not available.

If the ACB is not available, the FORWARD VEHICLE DETECTED telltale light will illuminate in red and will stay on and “ACB NOT AVAILABLE” pictogram will appear on the DID status line.



FORWARD VEHICLE DETECTED TELLTALE LIGHT



ACB NOT AVAILABLE PICTOGRAM

For proper functioning of the system, the radar must be perfectly aligned and not blocked. If a radar fault condition is detected, one of the following popup messages will show in the DID.

ACB RADAR MISALIGNMENT

ACB RADAR FAULT

ACB RADAR DATA LINK FAILURE

ACB RADAR BLOCKED

## WHAT TO EXPECT WHEN USING THE PREVOST DRIVER ASSIST™ SYSTEM

<b>PART 1</b> All driving scenarios (cruise control is either ON or OFF)		
<b>What to Expect</b>		
Situation	Typical system indication/alerts	Typical system actions/cautions
<b>Stationary objects/vehicles ahead in your lane of travel</b>		
A stationary ( <b>non-vehicle</b> ) object is present ahead in the lane in which the truck is traveling.	none	The driver must immediately act to potentially avoid, or lessen the severity of, a collision.
A stationary motor vehicle is detected ahead in your lane.  <i>Factors that can potentially affect the system's ability to identify a vehicle include: if the vehicle is not a licensed motorized vehicle; or certain types of trailers.</i>	If the vehicle is traveling above 10 mph / 16 km/h, a stationary vehicle alert may be issued up to three-and-a-half (3.5) seconds prior to impact.	The driver must immediately act to potentially avoid, or lessen the severity of, a collision.  If a collision is likely to occur, Prevost Driver Assist™ system can provide a warning and/or apply the vehicle service brakes.
<b>Moving objects/vehicles ahead in your lane of travel</b>		
Your vehicle comes up fast behind a slower-moving detected forward vehicle.	The Following Distance Alert (FDA) will sound and a visual message typically appears on the DID. Depending on how close your vehicle approaches, the system may initiate an Impact Alert (IA) warning.	None. You must respond as needed.
The detected forward vehicle slows rapidly.	The Following Distance Alert (FDA), or Impact Alert (IA) warning (continuous tone) will sound and a visual message typically appears on the DID.	None. You must respond as needed. If a collision is likely to occur, the collision mitigation feature will apply your vehicle's brakes.
A pedestrian, deer, or dog runs in front of your vehicle, or any organic or non-	None.	None. You must respond as needed.

metallic object is in front of your vehicle.		
Another vehicle crosses the road perpendicular to your path of travel – such as intersections.	None.	None. You must respond as needed.
A collision mitigation braking event has begun and you, as the driver, steers into an adjacent lane to avoid the forward vehicle.	None.	Prevost Driver Assist™ system will continue to apply the brakes if it detects another vehicle ahead in the new traffic lane posing a threat.
<b>Lane Departure Warning System Active (LDW pictogram being displayed)</b>		
Your vehicle signals a lane change and crosses a lane marking.	None.	None.
Traveling below 36 mph (58 km/h), your vehicle crosses a lane marker (without the corresponding turn signal activated).	None.	None. You must respond as needed.
Traveling above 36 mph (58 km/h), your vehicle departs your lane of travel without the corresponding turn signal activated.	An audible and visual alert is initiated.	None. You must respond as needed.  (use the turn signal when changing lanes and/or keep your vehicle within the lane markings).
<b>PART 2</b> ACB cruise control is ON and speed is SET		
<b>What to Expect</b>		
Situation	Typical system indication/alerts	Typical system actions/cautions
<b>Interactions with vehicles ahead in your lane of travel</b>		
With no detected forward vehicle.	None.	Your vehicle maintains the set speed.
With a detected forward vehicle.	The cruise control ON indicator is illuminated and the detected forward vehicle telltale is illuminated.	The Adaptive Cruise with Braking feature will maintain the set speed and following distance.

<p>The detected forward vehicle slows moderately.</p>	<p>The Following Distance Alert (FDA) will sound and a visual message typically appears on the DID.</p>	<p>You must respond as needed.  If the system intervenes, the vehicle throttle will be reduced; the engine retarder engaged; and the service brakes applied, in that order to maintain the set following distance.  <i>NOTE: When the ACB applies the service brakes, cruise control will automatically pause, and will cancel if vehicle speed falls below the minimum set speed or the driver manually depresses the brake pedal.</i></p>
<p>The detected forward vehicle slows rapidly.</p>	<p>The Impact Alert (IA) warning will sound and a visual message typically appears on the DID. The Following Distance Alert may also be heard.</p>	<p>You must respond as needed.  If the system intervenes, the vehicle throttle will be reduced; the engine retarder engaged; and the foundation brakes applied, in that order to maintain the set following distance.  <i>NOTE: When the ACB applies the foundation brakes, cruise control will automatically pause, and will cancel if vehicle speed falls below the minimum set speed or the driver manually depresses the brake pedal.</i></p>
<p>A detected forward vehicle cuts in front of your vehicle and speeds away.</p>	<p>Following Distance Alerts (FDAs) may be given to you, depending on the exact system configuration that has been set for the vehicle, and how close the vehicle cuts in front.</p>	<p>Vehicle maintains set speed.</p>
<p><b>Downhill Grades</b></p>		
<p>Going down a grade with a detected forward vehicle.</p>	<p><b>DO NOT USE</b> cruise control on downhill grades.</p>	<p><b>DO NOT USE</b> cruise control on downhill grades. Brake overuse may occur.</p>
<p>Cruise control should <i>NOT</i> be used on downhill grades.</p>		



## WARNING

*The section preceding shows examples of situations and typical Prevest Driver Assist™ system responses. However, the chart does not attempt to cover all possible situations.*

Due to the inherent limitations of radar and camera technology, the enhanced Collision Mitigation Technology – on rare occasions – may not detect moving vehicles or stationary vehicles in your vehicle's lane of travel. Alerts, warnings, or brake interventions may not occur.

Due to the inherent limitations of radar and camera technology, the enhanced Collision Mitigation Technology – on rare occasions – may react to moving vehicles not in your vehicle's lane of travel. Alerts, warnings, or brake interventions may occur.

## HOW YOUR ACTIONS IMPACT THE PREVOST DRIVER ASSIST™ SYSTEM

Your Action	Reactions of the Prevost Driver Assist™ system
If you, the driver, do this:	Expect the Prevost Driver Assist™ system to do this:
Step on the brake (during a collision mitigation event).	As the driver, you are always in control and are able to apply full braking power.
Step aggressively on the accelerator (during a collision mitigation event).	As the driver, you are always in control. Your actions override any Prevost Driver Assist™ system actions. NOTE: If cruise control is engaged, it will be overridden until the accelerator is released; then cruise control will resume the original set speed automatically.
Step on the brake (when in cruise).	Cruise control will be canceled.
Step on the accelerator (when in cruise).	Cruise control will be overridden until the accelerator is released; then cruise control will resume the original set speed automatically.
Switch ON the cruise control.	Nothing. The Active Cruise with Braking (braking to maintain a set following distance) feature will not engage until the driver sets the cruise control speed.
Switch OFF the cruise control.	The Active Cruise with Braking feature will turn off; the collision mitigation feature remains active and ready to intervene. You, the driver, will continue to hear all alerts as needed.
Set the cruise control speed.	The Active Cruise with Braking feature is automatically activated, and your vehicle maintains set speed and following distance behind the vehicle ahead in your lane of travel.

<p>Cover or block the radar or camera.</p>	<p>The Prevost Driver Assist™ system performance will be diminished, or disabled, when either the radar or the camera becomes blocked. An alert will be issued to alert the driver to indicate this condition.</p> <p>Radar: Radar blocked will be indicated through an alert and will disable the radar-based functions as follows:</p> <ul style="list-style-type: none"><li>- Loss of stationary vehicle braking SVB;</li><li>- Loss of forward-moving vehicle braking;</li><li>- Loss of ACB.</li></ul> <p>The camera based function LDW will remain.</p> <p>Camera: Camera blocked will be indicated through an alert and will disable all camera-based functions as follows:</p> <ul style="list-style-type: none"><li>- Loss of stationary vehicle braking SVB;</li><li>- Reduced braking performance on moving vehicle (speed reduction 15 mph / 24 km/h maximum);</li><li>- Loss of LDW.</li></ul> <p>The radar-based function ACB will remain.</p>
<p>Use normal cruise control “+/-” switch.</p>	<p>Vehicle speed increased (+) or reduced (-) to achieve the new set speed while actively maintaining the following distance with the vehicle ahead, if one is present within 500 feet / 152 meters.</p>