

WKJ7 - Replacing Coolant Pump (Workshop Campaign)

Revision: This bulletin replaces bulletin Group1, 137/19 WKJ7, dated April 23, 2020.

Model Year: **2020**

Model line: **911 (992)**

Subject: **Coolant pump**

Information: **During internal tests, Porsche has discovered that leaks can occur at the mechanical seal of the coolant pump over the service life of the vehicle.**

Coolant will escape if there is a leak. If this coolant loss goes unnoticed over a long period of time, a corresponding warning will be displayed in the instrument cluster.

Remedial Action: Replace coolant pump with an optimized variant.



Information

The vehicles affected by this workshop campaign may **also** be affected by the campaigns listed below:

- WKF2 Workshop campaign – Replacing pulse sender
- WKJ8 Workshop campaign – Replacing engine mounts and retrofitting caps

Given that some of the **tasks required for the respective workshop campaign will overlap, all campaigns required for the respective vehicle must be carried out together.**

Before carrying out this workshop campaign, please check therefore whether the vehicle is also affected by one or more of the campaigns specified above and always bear this in mind when carrying out this workshop campaign.

For **warranty processing** for this workshop campaign **together** with the **workshop campaign WKJ8**, see further information under ⇒ *Technical Information 'Warranty processing'*.

Affected Vehicles: Only vehicles assigned to the campaign (see also PCSS Vehicle Information). This recall affects 327 vehicles in North America.

Required parts and materials

Parts Info:	Part No.	Designation – Use	Qty.
	OPB121010D	⇒ Coolant pump, complete	1 ea.

992253143A	⇒ Clamping sleeve – Rear silencer to catalytic converter	2 ea.
9A700828100	⇒ O-ring, 31.0 x 3.00 – Coolant pipes to coolant pump	4 ea.
PAF008282	⇒ O-ring, 23.0 x 3.00 – Coolant pipe to coolant pump	2 ea.
OPB121139	⇒ Seal – Coolant guide to coolant pump	1 ea.
OPB121149	⇒ Seal – Coolant guide to engine block	1 ea.
PAF013814	⇒ Sealing ring, 14 x 18 – Screw plug for cooling system	2 ea.

Materials: **Required materials** (usually already available at the Porsche dealer):

Part No.	Designation – Use	Qty.
00004330516	⇒ Coolant additive, 20-liter container – Cooling system	As much as required (approx. 1 liter required per vehicle)
00004330539	⇒ Klüberplus lubricant, 100g tube – O-rings, seals	As much as required (approx. 5 grams required per vehicle)

Required tools

- Tools:
- **9696 - Filling device** for cooling system
 - **9696/1 - Cap**
 - **VAS 6096/2 Vacuum pump**
 - **VAG 1274B Tester for Cooling System**
 - **9900 - PIWIS Tester 3**
 - **9952 - Ring wrench**
 - **9866/1 - Spreader**
 - **9953 - Socket-wrench insert**
 - Torque screwdriver, 1.5–3 Nm (1–2 ftlb.), e.g. **Torque screwdriver, 1.5-3.0 Nm (1-2 ftlb.)**
 - Torque wrench, 2–10 Nm (1.5–7.5 ftlb.), e.g. **Torque wrench, 2-10 Nm (1.5-7.5 ftlb.)**
 - Torque wrench, 6–50 Nm (4.5–37 ftlb.), e.g. **Torque wrench, 6-50 Nm (4.5-37 ftlb.)**
 - Torque wrench, 40–200 Nm (30–148 ftlb.), e.g. **Torque wrench, 40-200 Nm (30-148 ftlb.)**
 - Battery charger with a current rating of **at least 90 A** and - if required - **also with a current and voltage-controlled charge map** for lithium starter batteries, e.g. **Battery charger 90A**

**Information**

The new 911 (992) comes with either a **lithium starter battery** (I-no. J2A) or an **AGM starter battery** (I-no. JOV, J4K) as standard.

This depends on the following:

- Country version
- Model type
- Vehicle equipment

Lithium starter batteries must only be charged using a **suitable battery charger** that has a current and voltage-controlled charge map.

For further information about the battery chargers to be used, see ⇒ *Workshop Manual '270689 Charging battery/vehicle electrical system'*.

Replace coolant pump

Work Procedure: 1 Drain coolant from the engine.

1.1 Raise the vehicle on a lifting platform ⇒ *Workshop Manual '4X00IN Lifting the vehicle'*.

1.2 Remove rear underbody cover ⇒ *Workshop Manual '519419 Removing and installing rear cover'*.

1.3 Drain coolant at the engine ⇒ *Workshop Manual '193817 Draining and filling coolant'*.

2 Remove rear silencers.

2.1 Remove rear apron ⇒ *Workshop Manual '635519 Removing and installing rear apron'*.

2.2 Remove rear bumper ⇒ *Workshop Manual '635019 Removing and installing rear bumper'*.

2.3 Remove rear silencer ⇒ *Workshop Manual '263319 Removing and installing rear silencer'*.

3 Remove heat shield for drive belt ⇒ *Workshop Manual '261419 Removing and installing heat shield (on belt drive)'*.

4 Loosen drive belt and remove it only from the coolant pump pulley.

For instructions, see ⇒ *Workshop Manual '137855 Replacing drive belt'*.

5 Remove coolant pump with housing.

- 5.1 Remove coolant pipe ⇒ *Lower coolant pipe -1-* from the coolant regulator housing.
- 5.1.1 Loosen and unscrew screw ⇒ *Lower coolant pipe -2-*.
- 5.1.2 Loosen spring band clamp ⇒ *Lower coolant pipe -3-*.
- 5.1.3 Pull off coolant hose ⇒ *Lower coolant pipe -4-*. Collect emerging coolant in a clean container.
- 5.1.4 Pull coolant pipe ⇒ *Lower coolant pipe -1-* out of the coolant regulator housing and remove it.

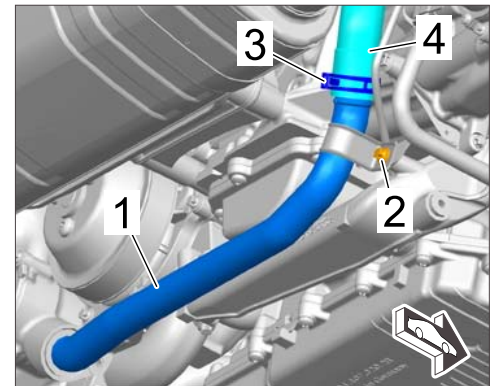

Lower coolant pipe

- 5.2 Loosen and unscrew screw ⇒ *Coolant pump holder -2-* on the coolant pump holder ⇒ *Coolant pump holder -1-*.

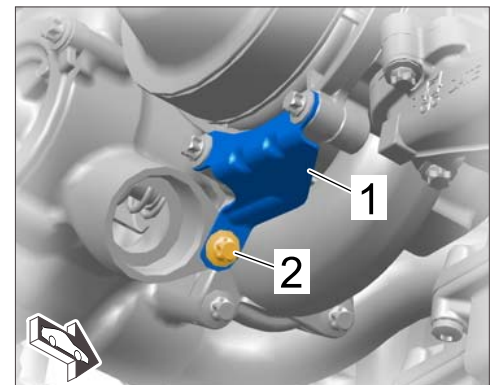

Coolant pump holder

- 5.3 Loosen coolant regulator housing ⇒ *Coolant regulator housing -4-*.
- 5.3.1 Release and disconnect electric plug connection on the coolant regulator.
- 5.3.2 Loosen and unscrew screws ⇒ *Coolant regulator housing -1 to 3-*.
- 5.3.3 Pull coolant regulator housing ⇒ *Coolant regulator housing -4-* off the coolant line ⇒ *Coolant regulator housing -5-* (⇒ *Coolant regulator housing -Arrow-*) and swivel it aside.

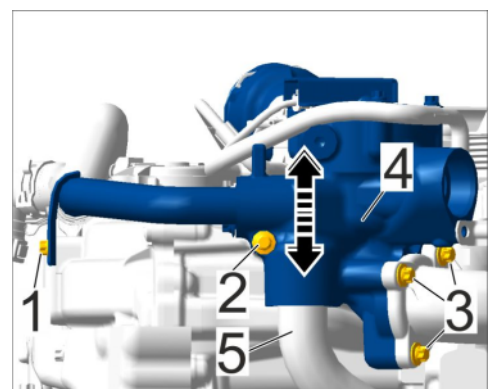

Coolant regulator housing

- 5.4 Remove coolant guide ⇒ *Coolant guide -1-*.
To do this, loosen and unscrew the screws ⇒ *Coolant guide -2-*.

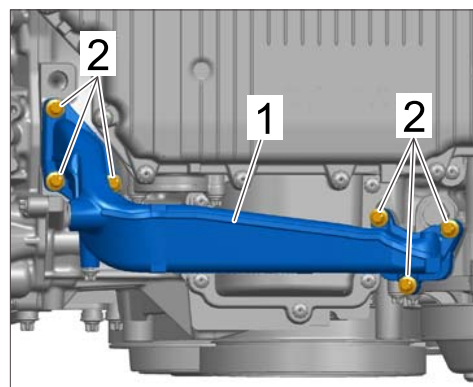

Coolant guide

- 5.5 Remove coolant pump with housing ⇒ *Coolant pump with housing -3-*.
- 5.5.1 Pull off vacuum line ⇒ *Coolant pump with housing -1-* on the coolant pump housing.
- 5.5.2 Unscrew screws ⇒ *Coolant pump with housing -2-* and pull coolant pump with housing ⇒ *Coolant pump with housing -3-* off the remaining coolant pipes.

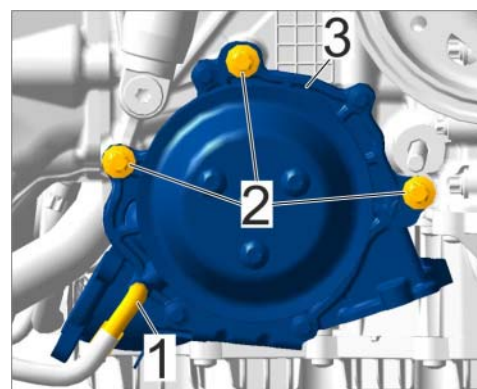

Coolant pump with housing

- 5.6 Replace all seals and O-rings and clean sealing faces.

- 6 Install new coolant pump with housing.



Information

- Coat O-rings, hoses and lines in the cooling system with Klüberplus Gel.

- 6.1 Install new coolant pump with housing ⇒ *Coolant pump with housing -3-*.

- 6.1.1 Fit coolant pump ⇒ *Coolant pump with housing -3-* and press it as far as it will go onto the coolant pipes. Screw in and tighten screws ⇒ *Coolant pump with housing -2-*.
Tightening torque 33 Nm (24 ftlb.)

- 6.1.2 Push vacuum line ⇒ *Coolant pump with housing -1-* fully onto the coolant pump housing.

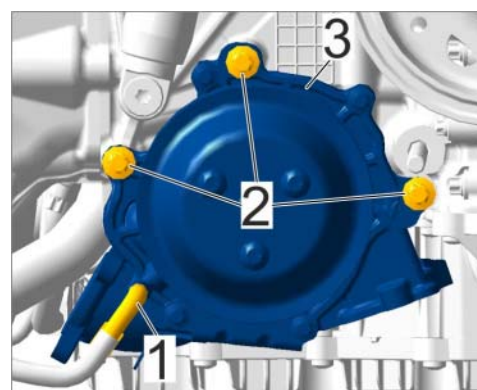

Coolant pump with housing

- 6.2 Install coolant guide ⇒ *Coolant guide -1-* with new seals.
To do this, screw in and tighten the screws ⇒ *Coolant guide -2-*.
Tightening torque 13 Nm (9.5 ftlb.)

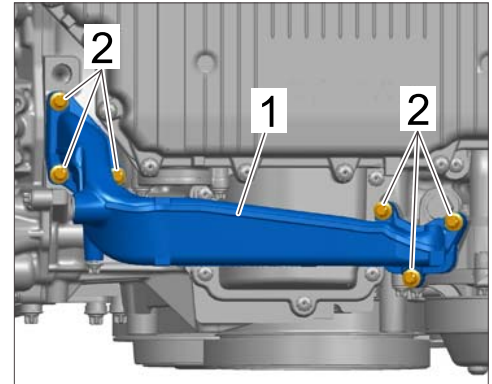

Coolant guide

- 6.3 Secure coolant regulator housing ⇒ *Coolant regulator housing -4-*.

- 6.3.1 Swivel housing ⇒ *Coolant regulator housing -4-* into installation position and push it onto the coolant line ⇒ *Coolant regulator housing -5-* (⇒ *Coolant regulator housing -Arrow-*).

- 6.3.2 Screw in and tighten screws ⇒ *Coolant regulator housing -1-* to *3-*.
Screw ⇒ *Coolant regulator housing -1-*: **Tightening torque 13 Nm (9.5 ftlb.)**

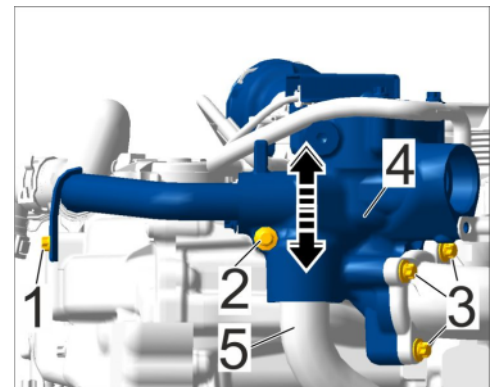

Coolant regulator housing

- Screw ⇒ *Coolant regulator housing -2-*: **Tightening torque 13 Nm (9.5 ftlb.)**
Screws ⇒ *Coolant regulator housing -3-*: **Tightening torque 13 Nm (9.5 ftlb.)**

- 6.3.3 Connect electric plug connection on the coolant regulator until the locking mechanism in the connector engages securely.
- 6.4 Screw in and tighten screw ⇒ *Coolant pump holder -2-* on the coolant pump holder ⇒ *Coolant pump holder -1-*.
Tightening torque 13 Nm (9.5 ftlb.)

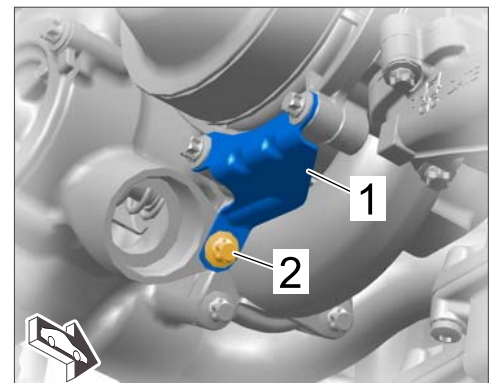

Coolant pump holder

- 6.5 Install coolant pipe ⇒ *Lower coolant pipe -1-*.
 - 6.5.1 Push coolant pipe ⇒ *Lower coolant pipe -1-* as far as it will go into the coolant regulator housing.
 - 6.5.2 Fit coolant hose ⇒ *Lower coolant pipe -4-* on the coolant pipe and secure with a spring band clamp ⇒ *Lower coolant pipe -3-*.
 - 6.5.3 Screw in and tighten screw ⇒ *Lower coolant pipe -2-*.
Tightening torque 13 Nm (9.5 ftlb.)

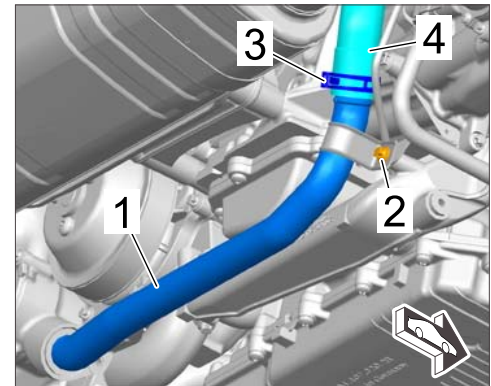

Lower coolant pipe

- 7 Re-install the drive belt that you loosened earlier.
For instructions, see ⇒ *Workshop Manual '137855 Replacing drive belt'*.
- 8 Install heat shield for drive belt ⇒ *Workshop Manual '261419 Removing and installing heat shield (on belt drive)'*.
- 9 Install rear silencers.
 - 9.1 Install rear silencer.
Use new clamps between the rear silencer and catalytic converters.
For instructions, see ⇒ *Workshop Manual '263319 Removing and installing rear silencer'*.
 - 9.2 Install rear bumper ⇒ *Workshop Manual '635019 Removing and installing rear bumper'*.
- 10 Fill the cooling system, bleed it and check for leaks.
⇒ *Workshop Manual '193817 Draining and filling coolant'*
⇒ *Workshop Manual '190107 Bleeding the cooling system'*
⇒ *Workshop Manual '190101 Checking the cooling system'*
- 11 Install rear apron ⇒ *Workshop Manual '635519 Removing and installing rear apron'*.
- 12 Install rear underbody cover ⇒ *Workshop Manual '519419 Removing and installing rear cover'*.
- 13 **Only for vehicles that have already been delivered:**
Enter the campaign in the Warranty and Maintenance booklet.

Warranty processing



Information

The specified working times were determined specifically for carrying out this campaign and may differ from the working times published in the Labor Operation List in PCSS.

**Information**

The vehicles affected by this workshop campaign may **also** be affected by the campaigns listed below:

- WKF2 Workshop campaign – Replacing pulse sender
- WKJ8 Workshop campaign – Replacing engine mounts and retrofitting caps

Given that some of the **tasks required for the respective workshop campaign will overlap, all campaigns required for the respective vehicle must be carried out together.**

For **warranty processing** for this campaign, two campaign scopes have been created:

- **Scope 1 – Combined scope**

This scope must be invoiced if this campaign was carried out **together** with the other campaigns specified above. All **overlapping tasks** are included in the working time for **workshop campaign WKJ8** and will be invoiced with campaign WKJ8.

- **Scope 2 – Full scope**

Scope 2 must only be invoiced if the respective vehicle was brought into the workshop **only** in order to carry out this campaign.

This scope includes all tasks required for carrying out this workshop campaign.

Scope 1: **Replacing coolant pump** – Carried out together with workshop campaign WKJ8

Working time:

Replacing coolant pump

Labor time: **169 TU**

Includes: Removing and installing rear silencer
Loosening and securing drive belt

Without: Overlapping tasks for workshop campaign WKJ8

Parts required:

OPB121010D	Coolant pump	1 ea.
992253143A	Clamping sleeve	2 ea.
9A700828100	O-ring, 31.0 x 3.00	4 ea.
PAF008282	O-ring, 23.0 x 3.00	2 ea.
OPB121139	Seal	1 ea.
OPB121149	Seal	1 ea.
PAF013814	Sealing ring, 14 x 18	2 ea.

Required materials:

00004330516	Coolant additive, 20-liter container	0.05 ea. (= approx. 1 liter)
00004330539	Klüberplus lubricant, 100g tube	0.05 ea. (= approx. 5 grams)

⇒ Damage Code WKJ7 066 000 2



Information

- **Scope 2 – Full scope**

Scope 2 must only be invoiced if the respective vehicle was brought into the workshop **only** in order to carry out this campaign.

This scope includes all tasks required for carrying out this workshop campaign.

Scope 2: **Replacing coolant pump – Full scope**

Working time:

Replacing coolant pump

Labor time: **468 TU**

- Includes:
- Draining and filling coolant, bleeding and checking the cooling system
 - Removing and installing cover for rear underbody
 - Removing and installing rear apron
 - Removing and installing rear bumper
 - Removing and installing rear silencer
 - Loosening and securing drive belt

Parts required:

OPB121010D	Coolant pump	1 ea.
992253143A	Clamping sleeve	2 ea.
9A700828100	O-ring, 31.0 x 3.00	4 ea.
PAF008282	O-ring, 23.0 x 3.00	2 ea.
OPB121139	Seal	1 ea.
OPB121149	Seal	1 ea.
PAF013814	Sealing ring, 14 x 18	2 ea.

Required materials:

00004330516	Coolant additive, 20-liter container	0.05 ea. (= approx. 1 liter)
00004330539	Klüberplus lubricant, 100g tube	0.05 ea. (= approx. 5 grams)

⇒ Damage Code WKJ7 066 000 2

Important Notice: Technical Bulletins issued by Porsche Cars North America, Inc. are intended only for use by professional automotive technicians who have attended Porsche service training courses. They are written to inform those technicians of conditions that may occur on some Porsche vehicles, or to provide information that could assist in the proper servicing of a vehicle. Porsche special tools may be necessary in order to perform certain operations identified in these bulletins. Use of tools and procedures other than those Porsche recommends in these bulletins may be detrimental to the safe operation of your vehicle, and may endanger the people working on it. Properly trained Porsche technicians have the equipment, tools, safety instructions, and know-how to do the job properly and safely. Part numbers listed in these bulletins are for reference only. The work procedures updated electronically in the Porsche PIWIS diagnostic and testing device take precedence and, in the event of a discrepancy, the work procedures in the PIWIS Tester are the ones that must be followed.

© 2020 Porsche Cars North America, Inc.