



## Ryker Fuel Pump Noise Modification - 137790

### Summary:

Part to install to reduce fuel pump noise

### Type:

General

### TST Detail:

- Ride the unit until the noise is audible (as per video attached in TST RYKER 2019 Noisy Fuel Pump - 136739). **Note**, to accelerate the process, remove fuel tank cover to be as quick as possible to remove the fuel pump and do the modification
- Once the noise is audible, stop the unit and remove the fuel pump as per manual shop procedures.
- With a flat screwdriver, pull carefully the 4 locking tabs

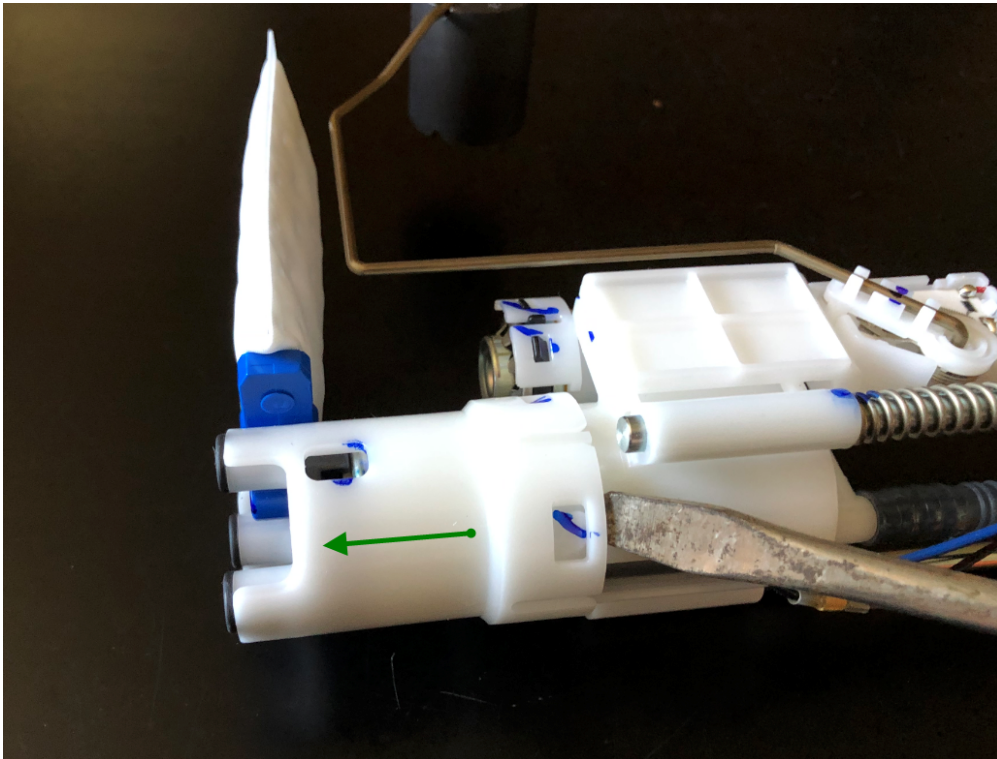

- Make sure to hold the pump well seated in its location while manipulating the whole ass'y.
- Remove the little black rubber insulator. Then, use a small flat screwdriver and remove the filter locking ring, then remove the filter. **Note**, make sure to hold the pump well seated in its location while manipulating the whole ass'y.

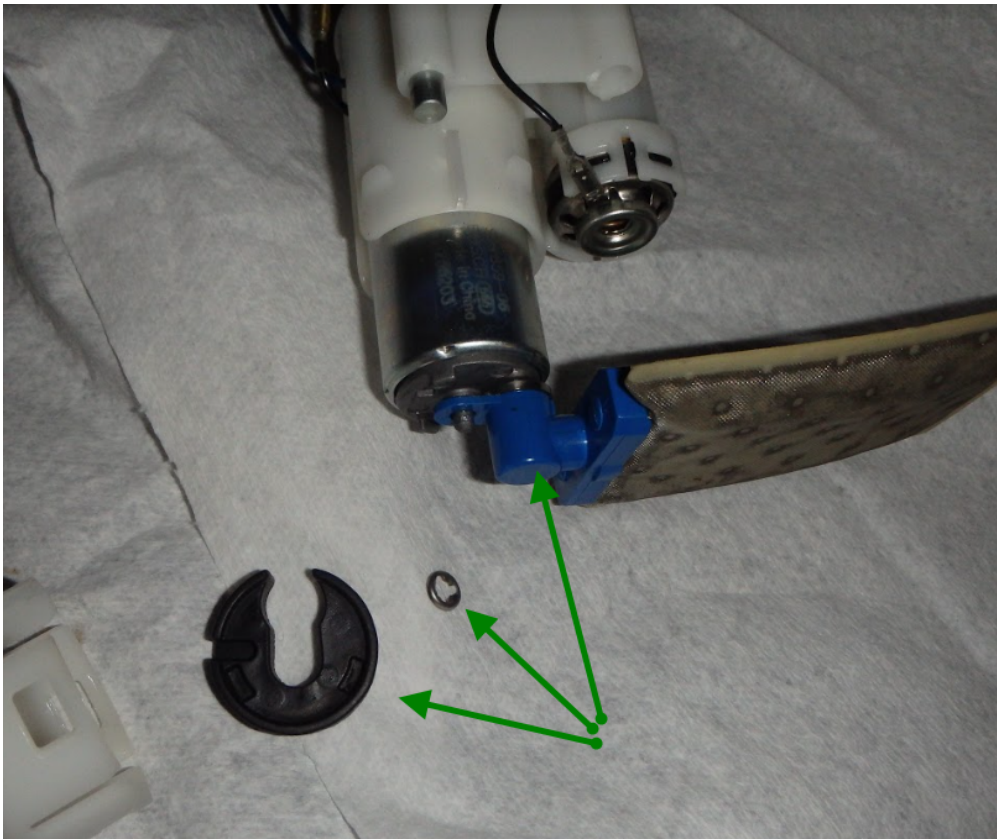

- Unplug the static ground

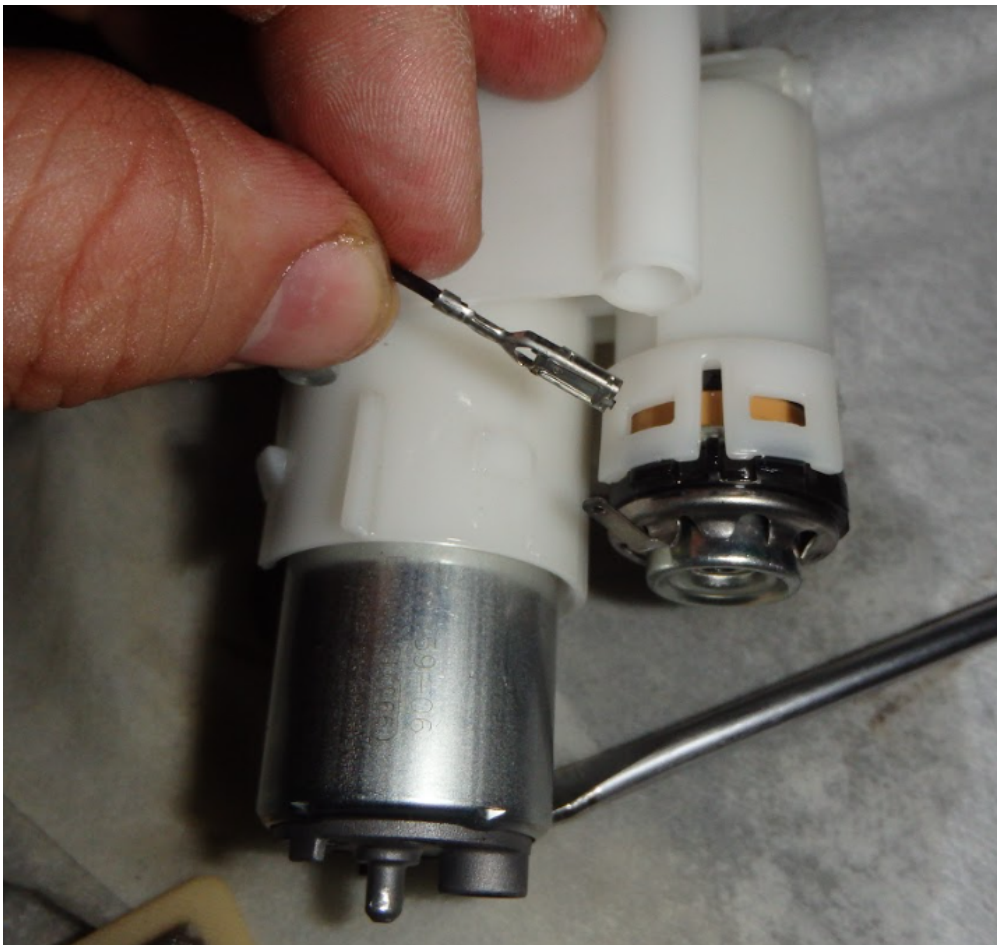

- With the help of a colleague, pull the regulator 4 locking tabs and at the same time, pry up the regulator with a flat screwdriver

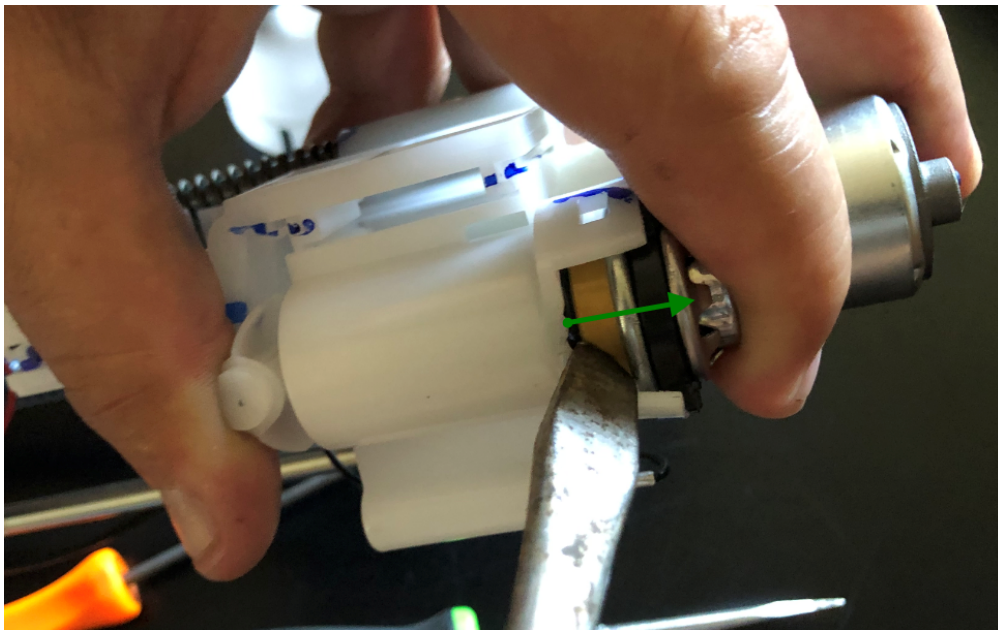

- Use a small amount of brake cleaner and spray the regulator plastic housing.
- Use compressed air to blow and dry the plastic
- Apply 2 drops of Loctite 4070 as shown below

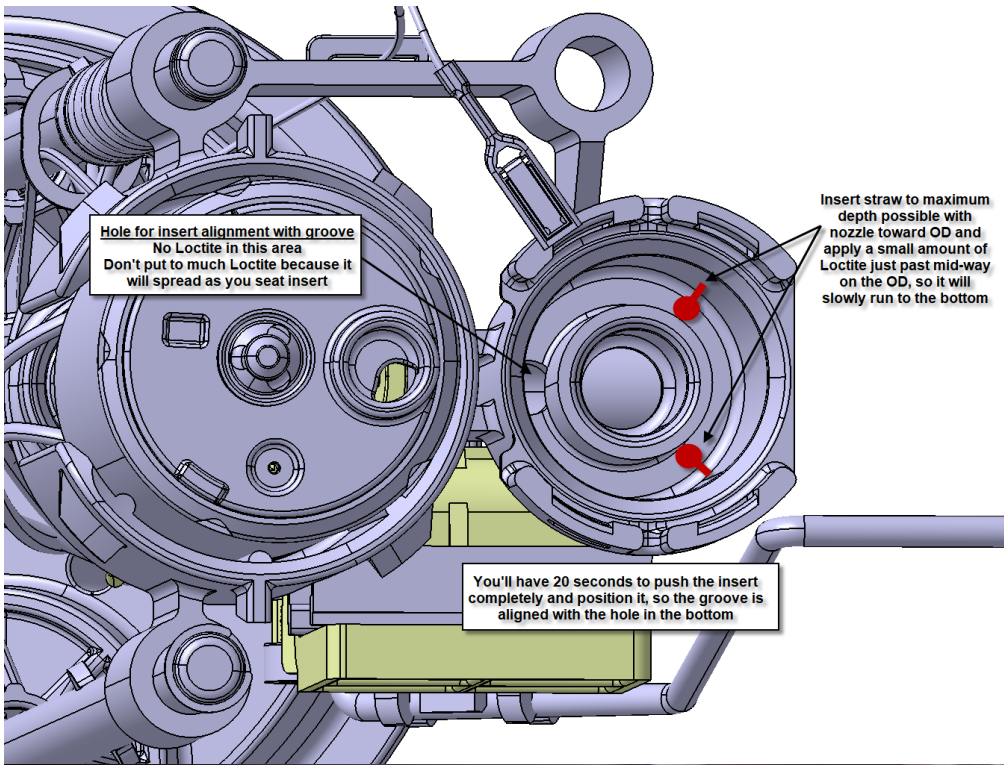



- It does not take a lot of Loctite on the 2 locations. I would say 2-3 "drops" even though it comes out as a continuous flow.
- Inclining the pump so that the hole is higher than the rest of the bottom surface where the insert is going to sit. **Important:** You have 20 seconds to insert and position the insert. **After that, too bad!**
- Add the insert with the open section as shown below.

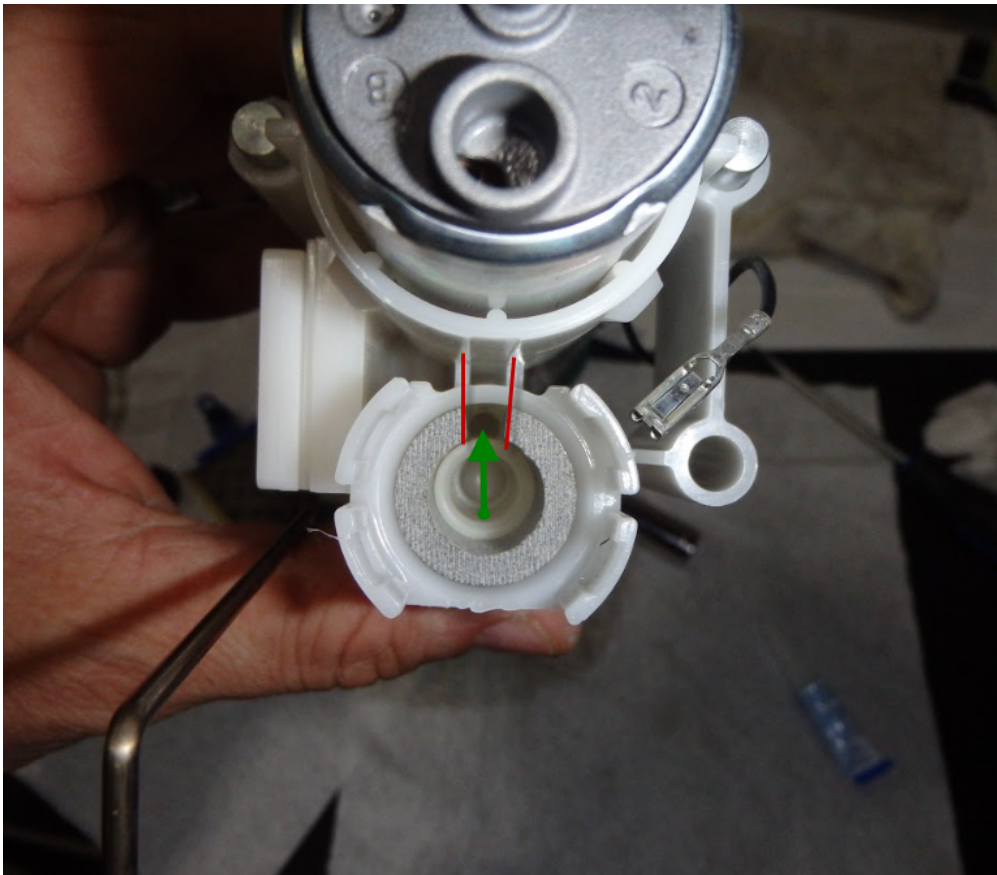

- Use a deep socket to push it down as shown below

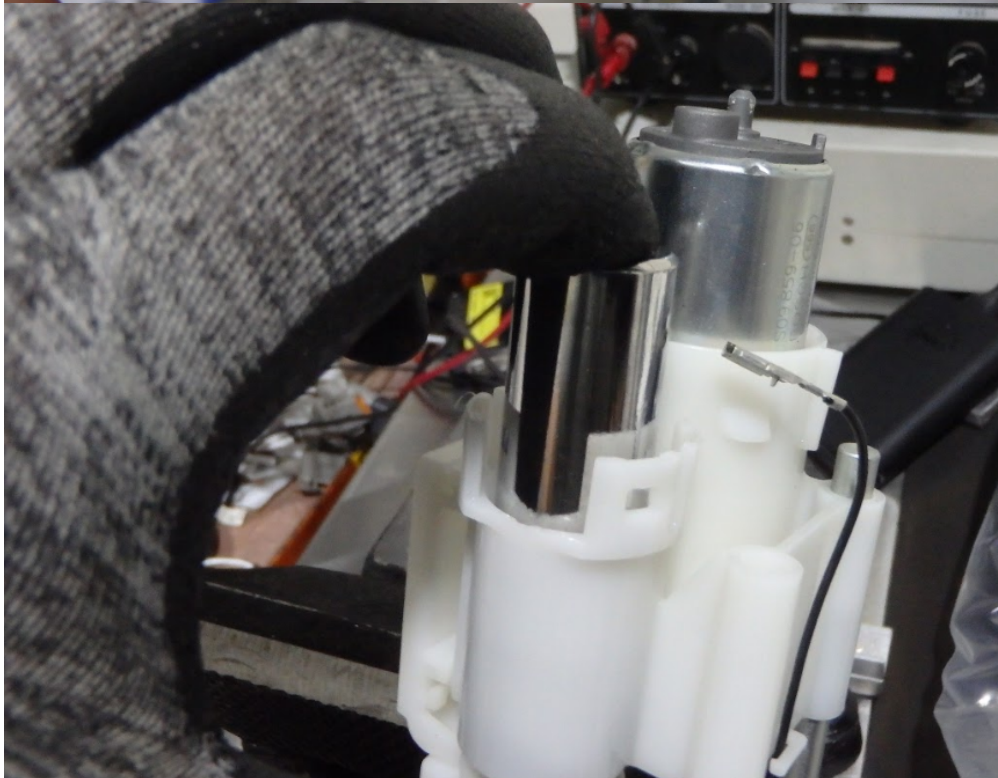

- Apply clean oil on the O-rings and re-assemble the pump.
- Always be careful to not bent the float lever.
- Wait 7 minutes before re-installing the fuel pump in the fuel (Loctite drying time is necessary)

**Attachment:**

---

**First Published By:** Eric Fauteux on 2020-06-19

**Last Modified By:** Eric Fauteux on 2020-06-22