

April 2020

Dealer Service Instructions for:

Customer Satisfaction Notification W17 Missing Side Steps

Remedy Available

2020 (JT) Jeep® Gladiator

NOTE: Some vehicles above may have been identified as not involved in this campaign and therefore have been excluded from this campaign.

IMPORTANT: Some of the involved vehicles may be in dealer new vehicle inventory. Dealers should also consider this requirement to apply to used vehicle inventory and should perform this campaign on vehicles in for service. Involved vehicles can be determined by using the VIP inquiry process.

Subject

The side steps on about 355 of the above vehicles may not have been installed on the vehicle during the manufacturing process. This option is included on all Overland North Edition models.

Repair

Install the side steps.

Parts Information

Part Number

82215608

Description

Molded Side Steps

Dealers should order the part package for each vehicle at the time appointments are scheduled to assure that the part is available when the customer arrives.

Parts Return

No parts return required for this campaign.

Special Tools

No special tools are required to perform this service procedure.

Service Procedure**A. Side Steps Installation Procedure**

1. Raise and support the vehicle on a hoist.
2. Install the side step (A) and install the four bolts (C) hand tight (Figure 1).
3. Install the eight nuts (D) and tighten to 13N·m (9.5ft.lbs.) (Figure 1).
4. Tighten the bolts (C) to 27.5N·m (20ft.lbs.) (Figure 1).
5. Repeat the same procedure for both sides.

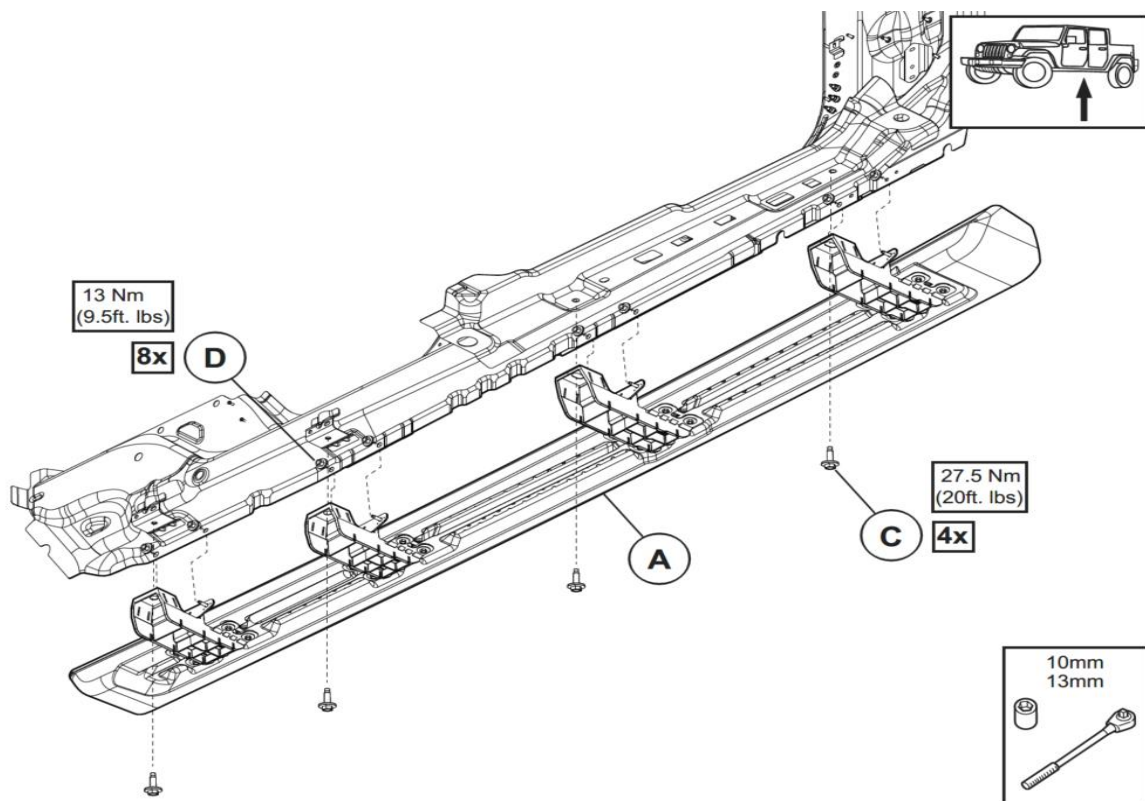
**Figure 1 – Side Step Installation**

6. Lower the vehicle and return it to the customer.

Completion Reporting and Reimbursement

Claims for vehicles that have been serviced must be submitted on the DealerCONNECT Claim Entry Screen located on the Service tab. Claims paid will be used by FCA to record Customer Satisfaction Notification service completions and provide dealer payments.

Use the following labor operation number and time allowance:

	Labor Operation Number	Time Allowance
Inspect for missing side steps	23-W1-71-81	0.2 hours
Install Side Steps	23-W1-71-82	0.8 hours

NOTE: See the Warranty Administration Manual, Recall Claim Processing Section, for complete claim processing instructions.

Dealer Notification

To view this notification on DealerCONNECT, select “Global Recall System” on the Service tab, then click on the description of this notification.

Owner Notification and Service Scheduling

All involved vehicle owners known to FCA are being notified of the service requirement by mail. They are requested to schedule appointments for this service with their dealers. A generic copy of the owner letter is attached.

Vehicle Lists, Global Recall System, VIP and Dealer Follow Up

All involved vehicles have been entered into the DealerCONNECT Global Recall System (GRS) and Vehicle Information Plus (VIP) for dealer inquiry as needed.

GRS provides involved dealers with an updated VIN list of their incomplete vehicles. The owner's name, address and phone number are listed if known. Completed vehicles are removed from GRS within several days of repair claim submission.

To use this system, click on the “**Service**” tab and then click on “**Global Recall System.**” Your dealer's VIN list for each recall displayed can be sorted by: those vehicles that were unsold at campaign launch, those with a phone number, city, zip code, or VIN sequence.

Dealers should perform this repair on all unsold vehicles before retail delivery. Dealers should also use the VIN list to follow up with all owners to schedule appointments for this repair.

VIN lists may contain confidential, restricted owner name and address information that was obtained from the Department of Motor Vehicles of various states. Use of this information is permitted for this notification only and is strictly prohibited from all other use.

Additional Information

If you have any questions or need assistance in completing this action, please contact your Service and Parts District Manager.

Customer Service / Field Operations
FCA US LLC

This notice applies to your vehicle,

[Model Year and Model]

VIN XXXXXXXXXXXXXXXXXXXX

W17

LOGO

VEHICLE PICTURE

YOUR SCHEDULING OPTIONS

- 1. RECOMMENDED OPTION**
Call your authorized Chrysler / Dodge / Jeep® / RAM Dealership
- 2. Call the FCA Recall Assistance Center at 1-800-853-1403.** An agent can confirm part availability and help schedule an appointment
- 3. Visit recalls.mopar.com, scan the QR code below, or download the Mopar Owner's Companion App.**

QR Code

Get access to recall notifications, locate your nearest dealer, and more through this website or Mopar Owner's Companion App. You will be asked to provide your Vehicle Identification Number (VIN) to protect and verify your identity.

DEALERSHIP INSTRUCTIONS

Please reference CSN W17.

CUSTOMER SATISFACTION NOTIFICATION

Missing Side Steps

Dear [Name],

At FCA US LLC, we recognize that the success of our business depends on the satisfaction of our customers. We are constantly monitoring the quality of our products and looking for opportunities to improve our vehicles even after they are sold. Because your long-term satisfaction is important to us, we are contacting you on important improvements we would like to make to your vehicle ^[1]. This will be done at no charge to you.

We are recommending the following improvements be performed on certain [2020 Model Year (JT) Jeep Gladiator] vehicles.

WHY DOES MY VEHICLE NEED REPAIRS?

Side steps are included on all Overland North Edition models. These side steps may not have been installed on your vehicle during the manufacturing process.

HOW DO I RESOLVE THIS CUSTOMER SATISFACTION NOTIFICATION?

FCA US will repair your vehicle free of charge (parts and labor). To do this, your dealer will install the side steps. The estimated repair time is about one hour. In addition, your dealer will require your vehicle for proper check-in, preparation, and check-out during your visit, which may require more time. Your time is important to us, so we recommend that you schedule a service appointment to minimize your inconvenience. Please bring this letter with you to your dealership.

**TO SCHEDULE YOUR FREE REPAIR,
CALL YOUR CHRYSLER, DODGE, JEEP OR RAM DEALER TODAY**

WHAT IF I ALREADY PAID TO HAVE THIS REPAIR COMPLETED?

If you have already experienced this specific condition and have paid to have it repaired, you may visit www.fcarecallreimbursement.com to submit your reimbursement request online. ^[2] Once we receive and verify the required documents, reimbursement will be sent to you within 60 days. If you have had previous repairs performed and/or already received reimbursement, you may still need to have the repair performed.

We apologize for any inconvenience, but are sincerely concerned about your satisfaction. Thank you for your attention to this important matter.

Customer Assistance/Field Operations
FCA US LLC



Mr. Mrs. Customer
1234 Main Street
Hometown, MI 48371

[1] If you no longer own this vehicle, please help us update our records. Call the FCA Recall Assistance Center at 1-800-853-1403 to update your information.

[2] You can also mail in your original receipts and proof of payment to the following address for reimbursement consideration: FCA Customer Assistance, P.O. Box 21-8004, Auburn Hills, MI 48321-8007, Attention: Recall Reimbursement.