

## STAR ONLINE PUBLICATION

**Case Number:** S2008000058

**Release Date:** 04/25/2020

**Symptom/Vehicle Issue:** Rear Power Liftgate Does Not Unlock

**Customer complaint/ technician observation:** Owner complains that the power liftgate does release to unlock the rear hatch when requested. Technician has observed the liftgate will not unlock with the handle or the remote unlock request.

**Repair Procedure:** Test the involved liftgate release driver circuit P31 to unlock the liftgate using the scan tool actuator function to confirm there is no change in the operation. If no change, inspect the BCM's liftgate unlock relay fuse 38 for an open, or no power feed and/or test the circuit further by using a fused power source and applying power from the BCM, C5, black 32 Way connector to test the P31 liftgate unlock circuit integrity, Fig 1, 2, 3.

**Wire Insertion Side:**

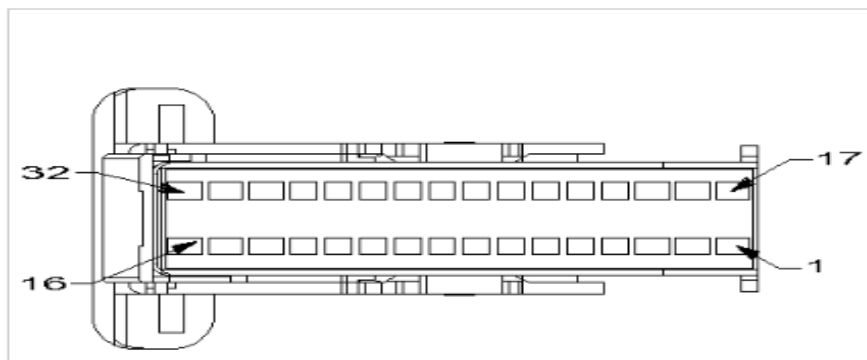

**Fig 1, C5 – BCM 32 way**

This document does not authorize warranty repairs. This communication documents a record of past experiences. STAR Online does not provide any conclusions about what is wrong with the vehicle. Rather, it captures all previous cases known that appear to be similar or related to the vehicle symptom / condition. You are the expert, and you are responsible for deciding on the appropriate course of action.

**Contact STAR Center, or your Technical Assistance Center Via TechCONNECT or eCONTACT ticket if no solution is found**

# STAR ONLINE PUBLICATION

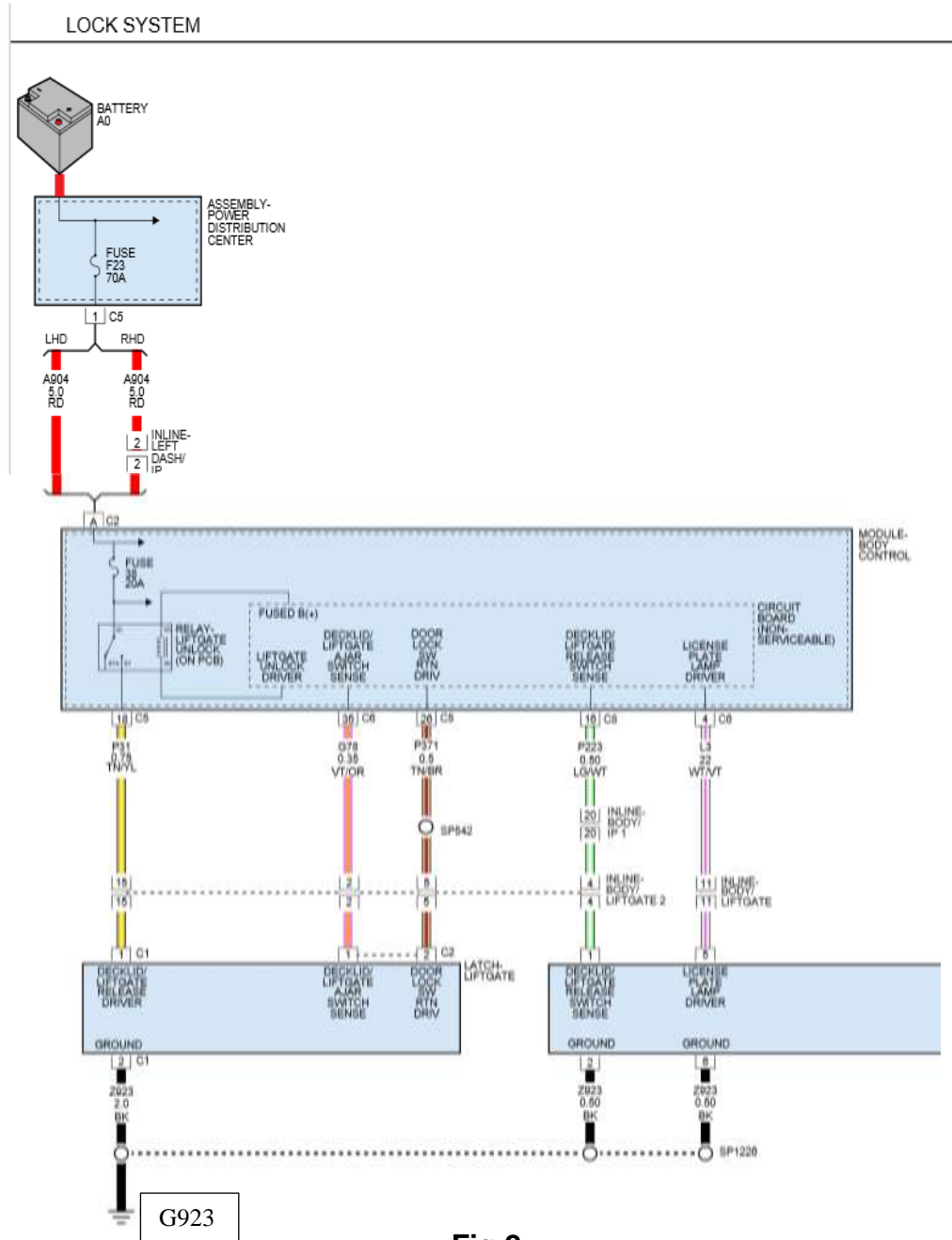

Fig 2

This document does not authorize warranty repairs. This communication documents a record of past experiences. STAR Online does not provide any conclusions about what is wrong with the vehicle. Rather, it captures all previous cases known that appear to be similar or related to the vehicle symptom / condition. You are the expert, and you are responsible for deciding on the appropriate course of action.

**Contact STAR Center, or your Technical Assistance Center Via TechCONNECT or eCONTACT ticket if no solution is found**

## STAR ONLINE PUBLICATION

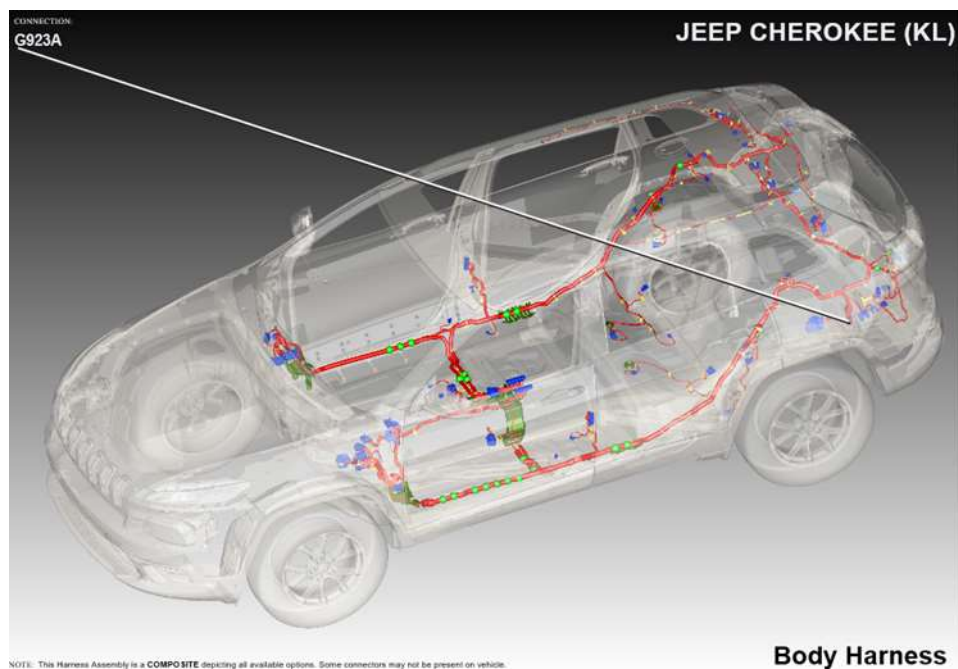

Fig 3

This document does not authorize warranty repairs. This communication documents a record of past experiences. STAR Online does not provide any conclusions about what is wrong with the vehicle. Rather, it captures all previous cases known that appear to be similar or related to the vehicle symptom / condition. You are the expert, and you are responsible for deciding on the appropriate course of action.

**Contact STAR Center, or your Technical Assistance Center Via TechCONNECT or eCONTACT ticket if no solution is found**