



DTC (Code) P1070-17 Codigo:	Bulletin: RD18-002 Date Fecha: January 20, 2019
Description: Gearbox Brake Valve (VAGB) - Circuit voltage above threshold	
Application: US13 – US20 Emissions	

General Information

These repair instructions are intended to address the following fault(s):

DTC	Description	Possible Cause	Possible (Observable) Symptoms
P1070 – 17	Gearbox Brake Valve (VAGB) - Circuit voltage above threshold	<ul style="list-style-type: none"> Solenoid valve assembly (VAGB) Wiring harness 	<ul style="list-style-type: none"> The solenoid valve and the brake are activated The transmission will be destroyed if you drive the vehicle The propeller shaft has to be removed to move the vehicle

Required Parts

Part Number	Description	Quantity
N/A	Please contact Parts Ordering/Transmission OEM for Solenoid Valve Replacement	1

Repair Instructions

Solenoid Valve, Valve Body, Replacement

*** Illustrations may differ slightly from the actual vehicle being serviced. However, key components addressed in this information are represented as accurately as possible.

*** All threaded fasteners that do not have a tightening torque specification in the information are tightened to a standard torque. Standard torques are available in Impact.

1. Remove the screws (1) and (2).

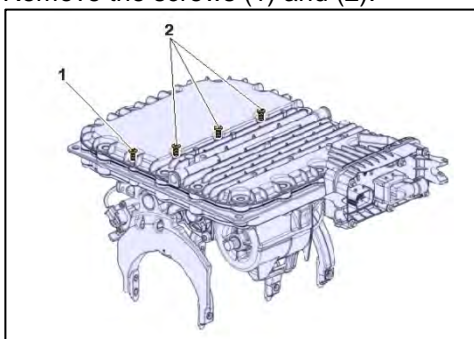



DTC (Code) P1070-17
Codigo:

Bulletin: RD18-002
Date Fecha: January 20, 2019

2. Remove the screws.

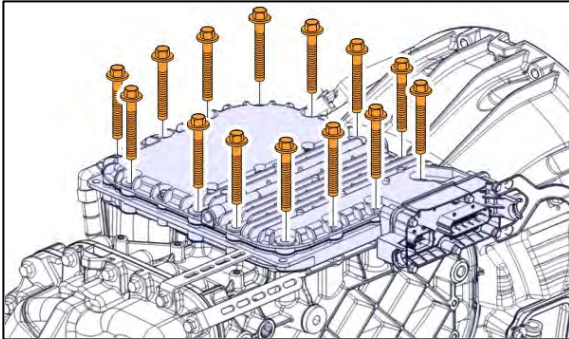

3. Raise the top cover. Note: Ensure that the cable harnesses are not damaged.
4. Disconnect the connectors.
5. Remove the top cover.

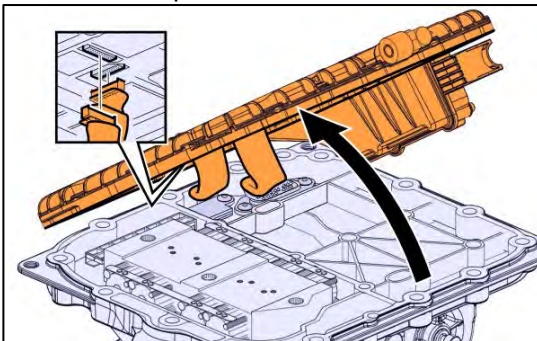

6. Remove the gasket.
7. Remove the seal.

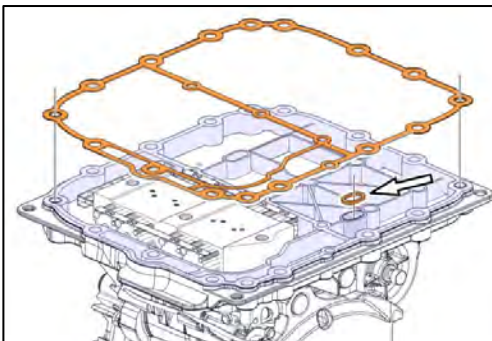

8. Remove the screws.
9. Remove the valve.



DTC (Code) P1070-17
Codigo:

Bulletin: RD18-002
Date Fecha: January 20, 2019

10. Remove the gasket.

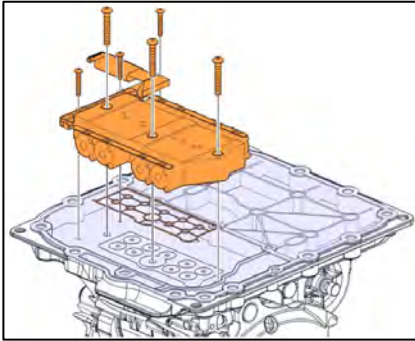

11. Clean the contact surfaces carefully.
12. Install the gasket. Note: Use a new part.
13. Install the valve.
14. Install the screws.
15. Torque tighten the screws (1).
Control housing valve, screw: 33 ± 1 Nm (24 ± 1 lbf-ft)
Required material
TORQUE WRENCH 88890148

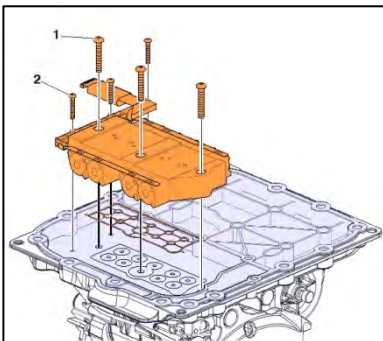

16. Tighten the screws (2).
17. Install the gasket. Note: Use a new part.
18. Install the seal. Note: Use a new part.

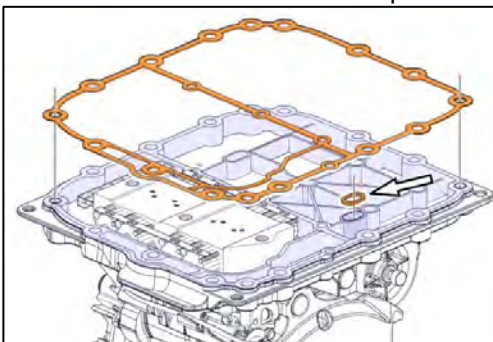

19. Connect the connectors.



DTC (Code) P1070-17
Codigo:

Bulletin: RD18-002
Date Fecha: January 20, 2019

20. Install the cover.

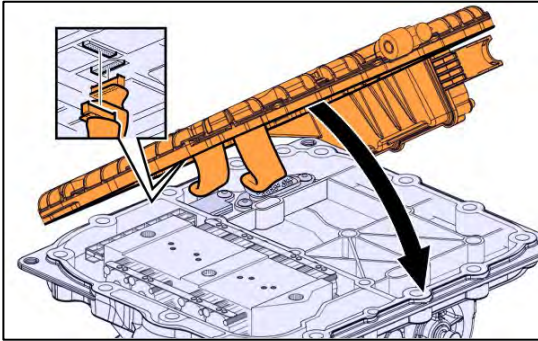

21. Install the screws (1) and (2).

22. Torque tighten the screws.

Control housing, screw
1. 28 ± 1 Nm (21 ± 1 lbf-ft)
2. 33 ± 1 Nm (24 ± 1 lbf-ft)

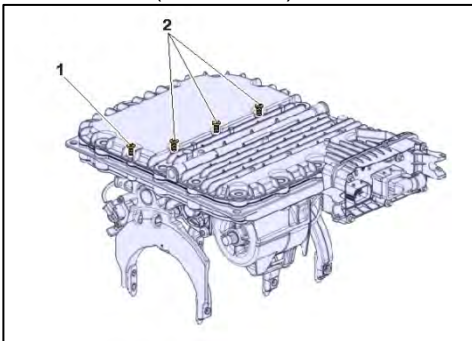

23. Clean all the threads. Note: Protect the parts from dirt. Service hint: Clean the threads without removing the control housing.

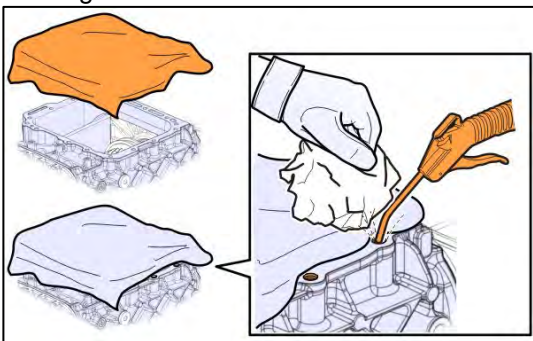

CAUTION: Risk of material damage. The screws are surface treated on delivery. Do not lubricate the screws.



DTC (Code) P1070-17
Codigo:

Bulletin: RD18-002
Date Fecha: January 20, 2019

24. Install the screws. Note: Start installing self tapping screws by hand to ensure correct location in the existing threads.

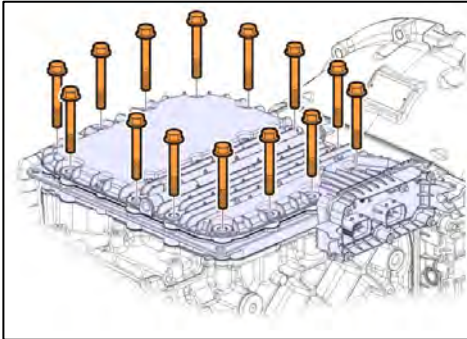

CAUTION: Risk of material damage. The screws are surface treated on delivery. Do not lubricate the screws.

25. Torque tighten the screws in sequence. Note: Torque tighten the screws diagonally.

Control housing, screw

1. Tightening sequence: 1. 75 ± 5 Nm (55 ± 4 lbf-ft)
2. Tightening sequence: 2. 95 ± 7 Nm (70 ± 5 lbf-ft)

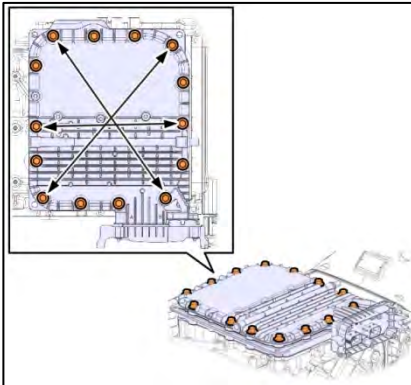

Additional Resources

These repairs are the most likely fix for the identified fault, if this does not fix the issue, Tech Tool will need to be used for more detailed diagnostics. If filing a warranty claim, please include the ASIST case number.

Labor Code	
4325-03-05-01	0.3
Causal Part	N/A