

# Service Update

## A202299960 Shift Lever Cable Bolt Not Fully Fastened



Release Date: April 2020

Revision: 00

**Attention:** This bulletin contains an inspection procedure for vehicles that are in dealer inventory. Vehicles that pass the inspection procedure contained in this bulletin can be sold and delivered to the customer. **Vehicles that DO NOT PASS the inspection procedure contained in this bulletin cannot be sold or delivered to the customer.** When parts become available, a revision will be made to this bulletin to allow for the repair of these vehicles, and floor plan reimbursement will also be added for vehicles which did not pass the inspection procedure.

**Vehicles that pass this inspection procedure can be delivered and closed using the “Inspect Only – Vehicle Passed Inspection (No Further Action Required)” labor code 9105059.**

It is a violation of Federal law for a dealer to deliver a new motor vehicle or any new or used item of motor vehicle equipment (including a tire) covered by this notification under a sale or lease until the defect or noncompliance is remedied.

All involved vehicles that are in New and Unsold dealer inventory must be held and not delivered to customers, dealer traded, or used for demonstration purposes until the inspection contained in this bulletin has been performed on the vehicle.

This service update involves vehicles in dealer inventory only and will expire April 30, 2021.

Make	Model	Model Year		RPO	Description
		From	To		
Buick	Encore GX	2020	2020	MRG or M3F	CVT Automatic Transmission or 9-speed Automatic Transmission
Chevrolet	Trailblazer	2021	2021	MRG or M3F	CVT Automatic Transmission or 9-speed Automatic Transmission

**Note:** This inspection procedure should be performed on vehicles in dealer inventory only. Please select the appropriate labor code when submitting the claim.

<b>Condition</b>	The gear shift lever may have a detent feel between Park and Reverse caused by the fastening bolt that is not fully seated and contacting the shifter housing.
<b>Inspection</b>	Dealers are to inspect the detent feel of the transmission range selector lever.

### Parts

No parts are required for this inspection procedure.

### Warranty Information

Labor Operation	Description	Labor Time	Trans. Type	Net Item
9105059	Inspect Only – Vehicle <b>Passed</b> Inspection (No Further Action Required)	0.2	ZFAT	N/A
9105060	Inspect Only – Vehicle <b>Did Not Pass</b> Inspection and Will Require Repair	0.2	ZFAT	N/A

**Important: Please select the appropriate labor code when submitting the claim. 9105059 should only be used if the vehicle PASSED the inspection.**

**Note: When parts become available and the revised bulletin is released, Floor Plan Reimbursement will be included for vehicles which did not pass the inspection procedure.**

### Service Procedure

1. Park the vehicle in a safe location and put the transmission in Park.
2. Start the engine and apply the brake pedal.
3. Slowly cycle the gear range selector from Park all the way down to Low range, taking your time to check the detent feel at each selector position. Do this from Park to Low and then back to Park three (3) full cycles.
  - If the Transmission Range Selector Lever is getting stuck or feels abnormal between Park and Reverse positions, refer to step 4.

## Service Update

### A202299960 Shift Lever Cable Bolt Not Fully Fastened



- If the Transmission Range Selector Lever is NOT getting stuck or feeling abnormal between the Park and Reverse positions, no further action is required.

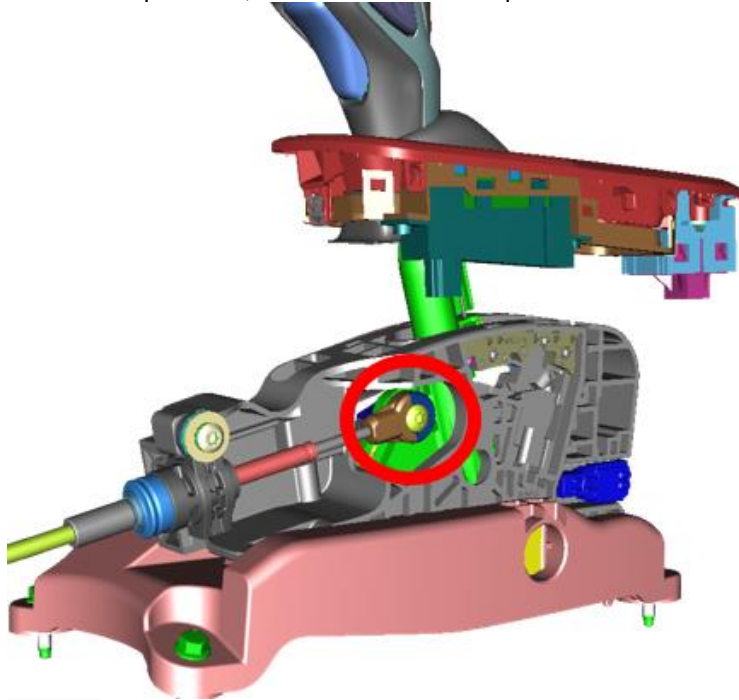

5569860

**Caution:** During part replacement, check to ensure the circled fastener is fully seated.

4. Hold the vehicle for repair until parts are available.

#### Dealer Responsibility

Dealers must take the steps necessary to ensure that the service update correction has been made to all involved vehicles in dealer inventory before selling or dealer-trading the vehicle, but no later than April 30, 2021.

All new, used, GM Certified Used, courtesy transportation vehicles, dealer shuttle vehicles, etc. in dealers' possession and subject to this bulletin must be held and inspected/repared per the service procedure of this bulletin before customers take possession of these vehicles. Involved vehicles must be held and not delivered to customers, dealer-traded, released to auction, used for demonstration, or any other purpose.

All GM Certified Used vehicles currently in the dealers' inventory within the Certified Pre-Owned Inventory System (CPOIS) will be de-certified and must be held and remedied per the service procedure in this bulletin. Upon submitting an accepted/paid warranty transaction in the Global Warranty Management (GWM) system, the vehicle can be re-certified for sale within the CPOIS system, or once again be used in the CTP program.

GM bulletins are intended for use by professional technicians, NOT a "do-it-yourselfer". They are written to inform these technicians of conditions that may occur on some vehicles, or to provide information that could assist in the proper service of a vehicle. Properly trained technicians have the tools, equipment, safety instructions, and know-how to do a job properly and safely. If a condition is described, DO NOT assume that the bulletin applies to your vehicle, or that your vehicle will have that condition. See your dealer for information on whether your vehicle may benefit from the information.



We Support  
Voluntary Technician  
Certification

GLOBAL SAFETY FIELD INVESTIGATIONS  
DCS5373  
URGENT - DISTRIBUTE IMMEDIATELY

Date: April 7, 2020

Subject: A202299960 - Service Update  
Shift Lever Cable Bolt Not Fully Fastened

Models: 2020 Buick Encore GX  
2021 Chevrolet Trailblazer  
Equipped with CVT Automatic Transmission or 9-speed Automatic  
Transmission (RPO MRG or M3F)

To: All General Motors Dealers

General Motors is releasing Service Update A202299960 today. The total number of U.S. vehicles involved is approximately 500. Please see the attached bulletin for details.

**Global Warranty Management (GWM)**

The Required Field Action section on the Investigate Vehicle History (IVH) screen will be updated April 8, 2020 or sooner. A list of involved vehicles in dealer new inventory is attached to this message. Please hold all warranty transactions until IVH has been updated.

END OF MESSAGE

GLOBAL SAFETY FIELD INVESTIGATIONS