



Subject: Rear Axle Remote Breather Retrofit			
Field change Program: Service Bulletin	Bulletin Number: 3137	Revision: A	Date: 04/27/2020
Coach Section: 02- Rear Axle	P/N: 02-01-1419, 02-01-1421, 02-01-1548		Type: Product Improvement

Application:

Coach Model	Model Year	VIN
J4500	All coaches starting MY 2018, VIN:68377	
J3500	68877, 68909, 68965, All coaches starting MY 2019, VIN: 21000	

WARNING

Read this entire procedure before beginning work.

Use Safe Shop Practices at All Times.

To avoid personal injury:

- a. Proper Personal Protective Equipment (PPE) must be worn. Safety glasses and protective gloves are required for working with DEF Fluid.*
- b. Turn the main battery disconnect switch to the OFF position.*
- c. Ensure that both the front and the rear wheels are chocked.*
- d. Position the ENGINE RUN and ENGINE START switches on the engine compartment remote control box to the OFF position.*
- e. Allow enough time for components to cool down prior to working in the engine compartment.*

1.0 Description

This bulletin outlines the steps to replace the breather plug with a remote breather on the ZF axle differential to avoid possible breather clogging when the coach drives through mud and water.

2.0 Material requirements

ITEM	PART NO	QTY	U/M	DESCRIPTION
1	02-01-1404	1	EA	Fitting- Breather Elbow, 90 deg, 6mm tube
2	19-11-259	5	EA	Tie- Cable, 3/8-3 1/2 Dia
3	24-54-027	5.5	FT	Loom Corr - .25ID
4	24-54-0199	5.5	FT	Tubing-Nylon-Flexible-BLK, 6mm OD X 1

3.0 Special tools

Loctite 243, MCI P/N: 23-02-0027, or similar.

4.0 Procedure

Lift the coach at the specified locations as per MCI Maintenance manual.

J4500 Jacking points:

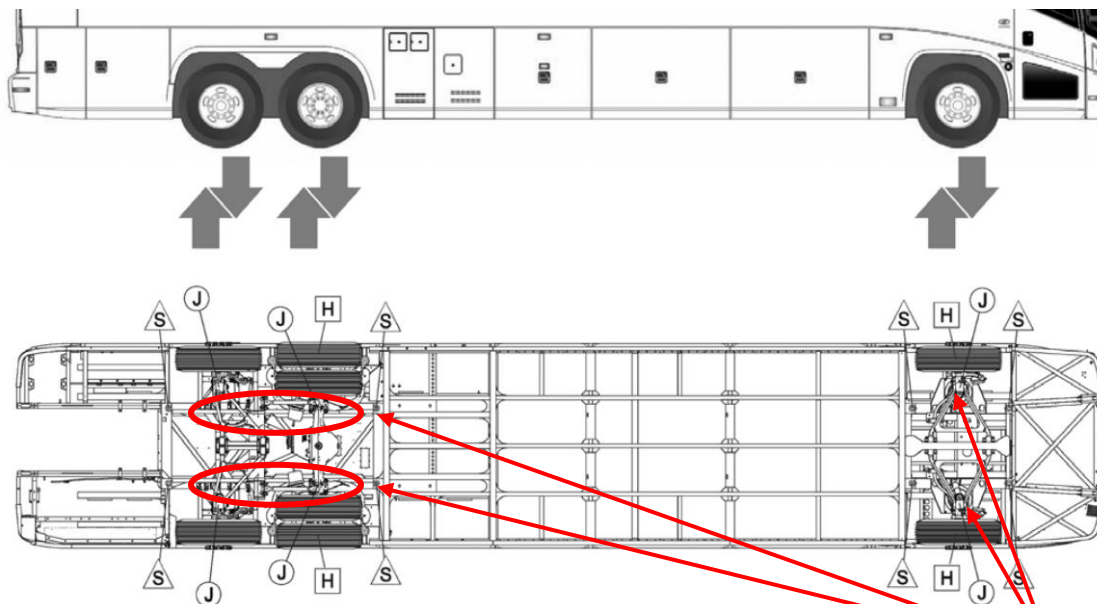

- △ S - Safety Stand (Primary Locations)
- J - Jacking Point
- H - Hoisting Point

Lift the coach at the six jacking points

J3500 Jacking points:

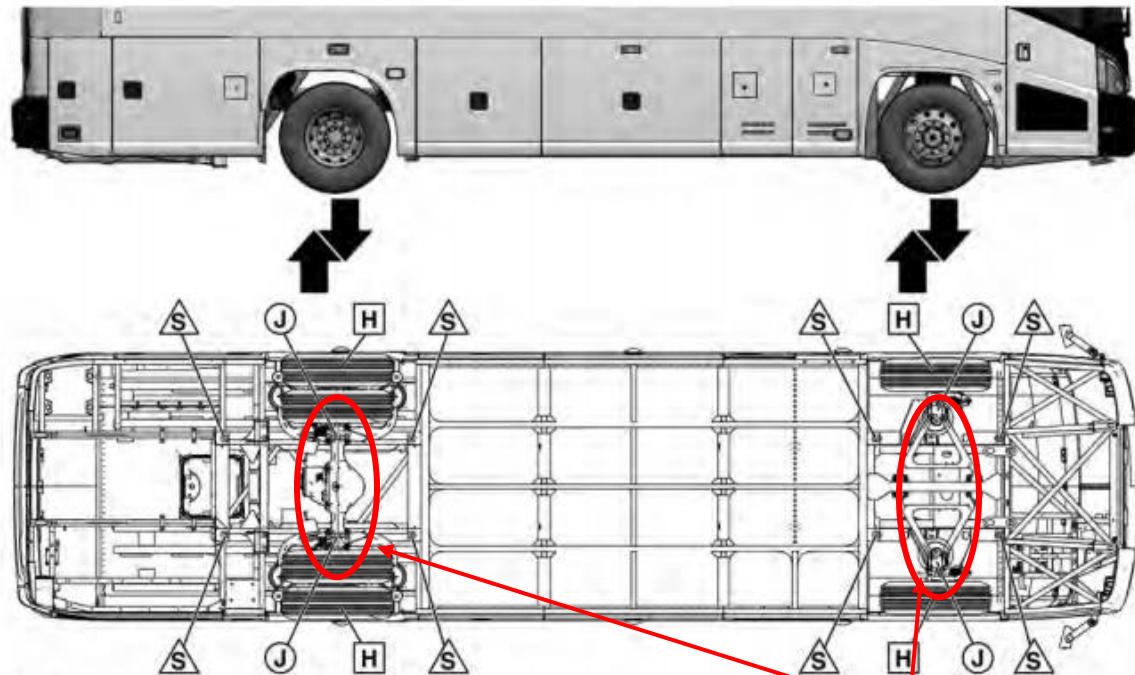

- S** - Safety Stand (Primary Locations)
- J** - Jacking Point
- H** - Hoisting Point

Lift the coach at the four jacking points

Remove and discard the existing breather.

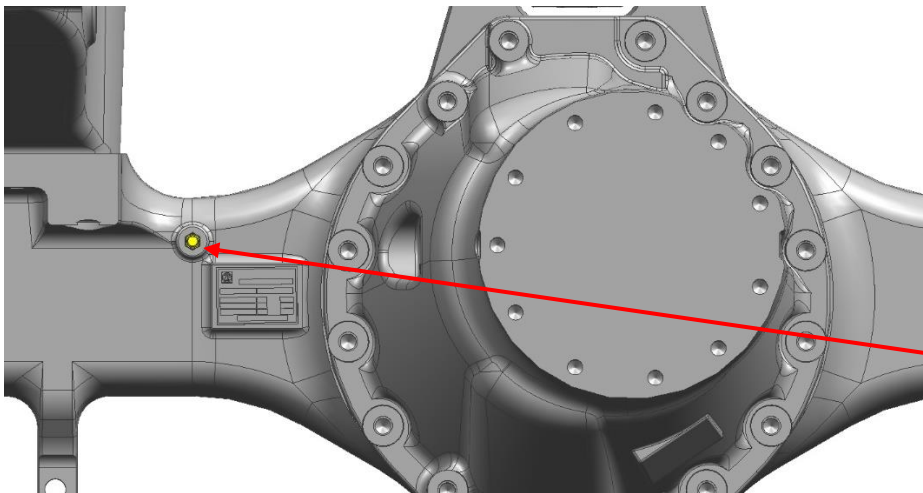

Remove and discard the breather

Apply Loctite, MCI P/N: 23-02-0088, to the breather fitting, MCI P/N: 02-01-1404, and install it into the threaded port. Torque the fitting to 44-53 In-Lbs.

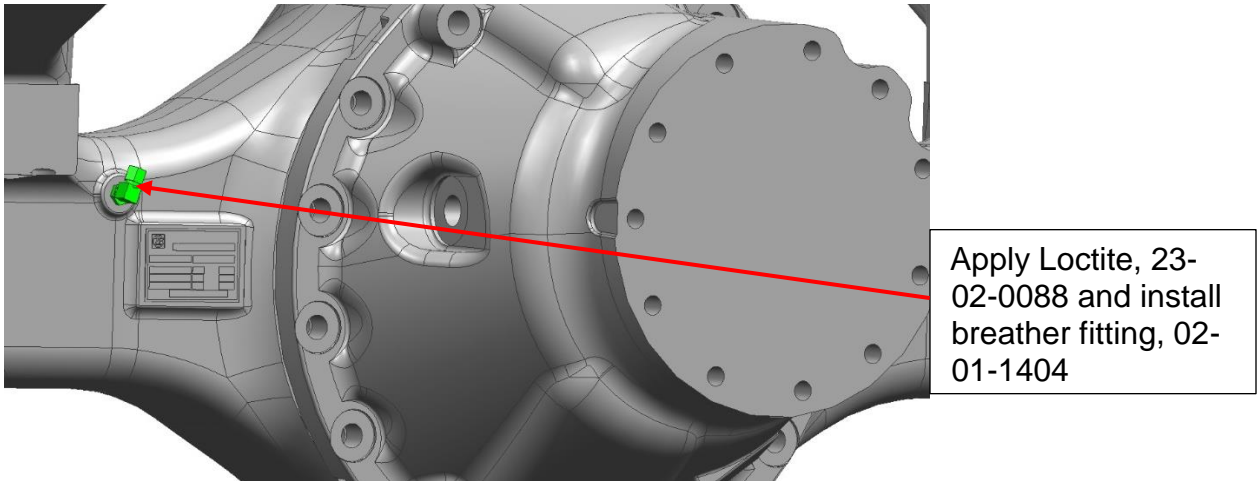

Make a mark on the nylon tube at 19.5mm (0.76") and insert the tube into the fitting up to the mark. Then pull back slightly to ensure good contact with internal sealing surfaces of the fitting. Install loom to the nylon tube.

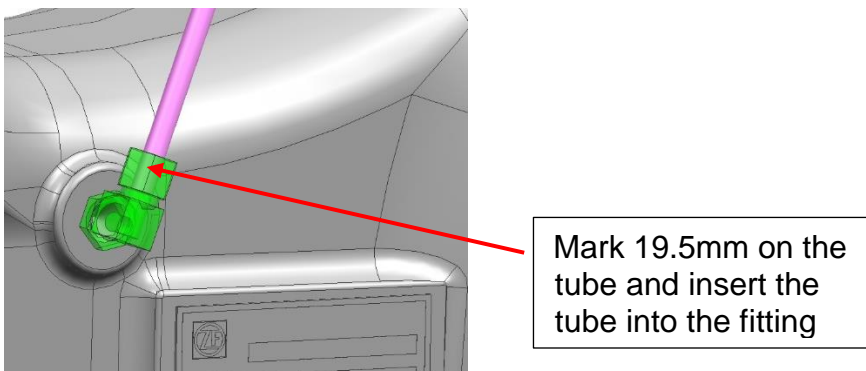

Raise the tube 15" from the fitting end and route the tube along the axle control arm, as shown below. Secure the tube to the control arm using zip ties, MCI P/N: 19-11-259.

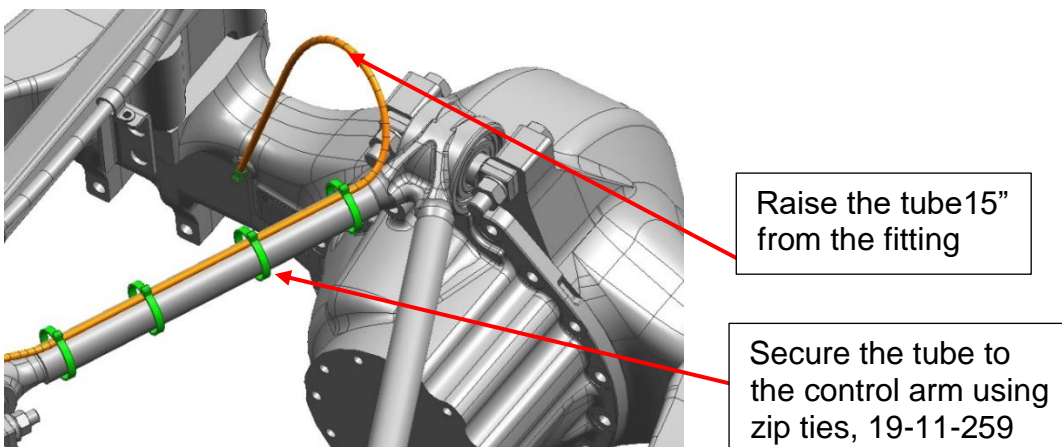

Secure the nylon tube to the tag axle brake hose (rear brake hose for J3500 coaches) using a zip tie, MCI P/N: 19-11-259.

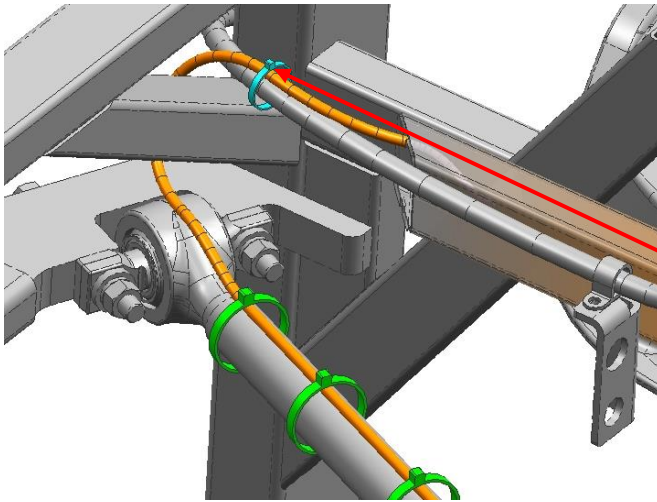

Secure the tube to the tag axle brake hose using zip tie, 19-11-259

Cut the free end of the nylon tube at 45° and insert the tube into the opening in the coach frame.

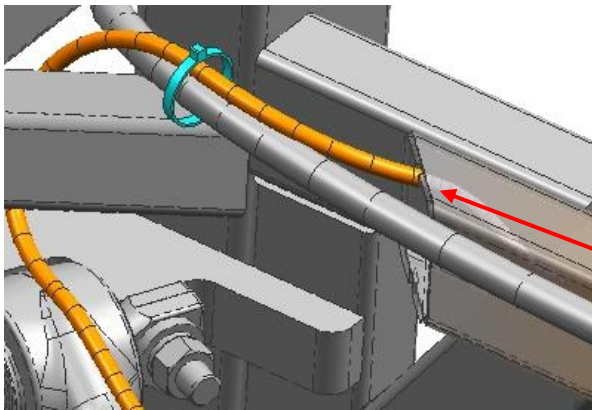

Cut the free end at 45° and insert the tube into the frame tube

End of the procedure