

# Authorized Field Change



AFC 20902

Date: APRIL 2020

Subject File: TRANSMISSION

**Subject:** Transfer Case O-Ring Seal

Model: International® CV™ Series

Start Date: 02 April 2019 End Date: 22 May 2019

Engine Family: N/A

## DESCRIPTION

The transfer case may develop an oil leak from the front input shaft bearing retainer or the idler pulley bearing retainer.

## ELIGIBILITY

This procedure applies ONLY to vehicles marked in the International® Service Portal<sup>SM</sup> with AFC 20902. Check and complete any other open campaigns also at this time.

## TOOLS INFORMATION

Table 1. [Special Tool Information](#)

NPN	Vernier Caliper
-----	-----------------

## PARTS INFORMATION

Table 2. [Parts Information](#)

Part Number	Description	Quantity
2515953C1	O-Ring Seal	2
Source Locally	40W Full Synthetic Lube	6 Pints
Source Locally	Loctite® 242 Threadlocker	As Needed

## SERVICE PROCEDURE

 **WARNING:** To prevent personal injury and / or death, or damage to property, park vehicle on hard flat surface, turn the engine off, set the parking brake, and install wheel chocks to prevent the vehicle from moving in both directions.

 **WARNING:** To prevent personal injury and / or death, or damage to property, if the vehicle must be raised, do not work under the vehicle supported only by jacks. Jacks can slip or fall over.

 **WARNING:** To prevent personal injury and / or death, or damage to property, always wear safe eye protection when performing vehicle maintenance.

 **WARNING:** To prevent personal injury and / or death, or damage to property, allow components in engine compartment to cool before servicing engine or vehicle.

 **WARNING:** To prevent personal injury and / or death, or damage to property, keep flames or sparks away from vehicle and do not smoke while servicing the vehicle's batteries. Batteries expel explosive gases.

1. Park vehicle on flat surface with wheels straight ahead.
2. Shift transmission to Park or Neutral and set parking brake.
3. Turn vehicle ignition to Key OFF position.
4. Install wheel chocks.
5. If necessary, raise vehicle with a jack and place on suitable jack stands.

**NOTE:** If you suspect that the transfer case has internal damage, contact Meritor Ontrac prior to proceeding with repair.

6. Using Inspection procedure in Meritor Technical Bulletin TP-2043, inspect serial number (S/N) on the transfer case.
  - a. If the serial number is in the range of LRS01290649 through LRS01318770, proceed with the Repair Procedures in the Meritor Technical Bulletin.
  - b. If the serial number is outside of LRS01290649 through LRS01318770, no further action is necessary. Proceed to Step 7.
7. If necessary, remove jack stands and lower vehicle.
8. Remove wheel chocks.

## LABOR INFORMATION

Operation number must appear on all claims.

**Table 3. Labor Information**

Operation No.	Description	Time
A40-20902-1	Inspect Serial Number; No Repair Required	0.1 hrs
A40-20902-2	Inspect Serial Number and Replace Two O-Rings	0.9 hrs

## ADMINISTRATIVE PROCEDURE

Expense is to be charged to Warranty. Claims are to be submitted in the normal manner, making reference to Authorized Field Change Number 20902

Section 7 of the Warranty Policy and Procedures Manual contains further information related to the submission and processing of AFC / Recall claims.

As with all claim submissions, items acquired locally must be submitted in the "Other Charges" tab. The cost of any bulk items (such as a bag of cable tie straps, roll of wire, barrel of oil, or tube of silicone) should be prorated for the cost of the individual pieces / amount used during each repair.

To ensure this important improvement is made in a timely manner, all claims for 20902 activity must be submitted by 01 April 2021 or within the normal warranty period for the vehicle, if after 01 April 2021.

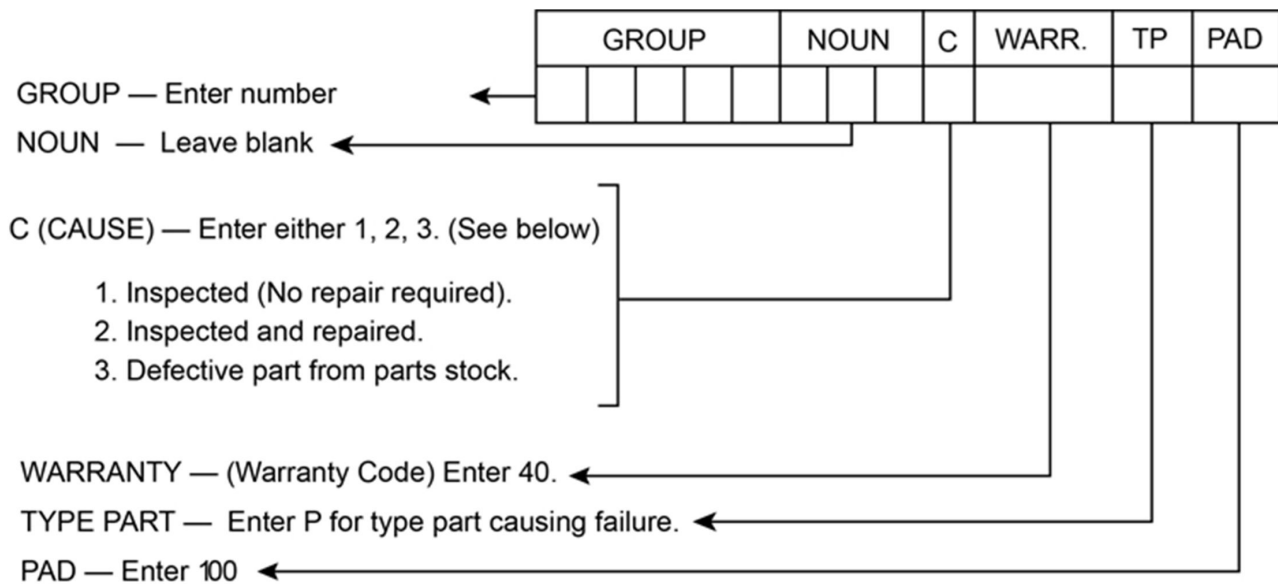

0000047910



## Technical Bulletin

# Transfer Case Adjustable Bearing Carrier O-ring Replacement

MTC-3203-AD02-100-300 Model Variants

## Hazard Alert Messages

Read and observe all Warning and Caution hazard alert messages in this publication. They provide information that can help prevent serious personal injury, damage to components, or both.

### WARNING

To prevent serious eye injury, always wear safe eye protection when you perform vehicle maintenance or service.

Park the vehicle on a level surface. Block the wheels to prevent the vehicle from moving. Support the vehicle with safety stands. Do not work under a vehicle supported only by jacks. Jacks can slip and fall over. Serious personal injury and damage to components can result.

## How to Obtain Additional Maintenance, Service and Product Information

Refer to Maintenance Manual MM-17114, Transfer Case, MTC-3203-AD02-100-300 Series Model. To obtain this publication, visit Literature on Demand at [meritor.com](http://meritor.com).

## How to Obtain Parts

Contact the vehicle manufacturer to obtain necessary service parts.

## Replacing the Adjustable Bearing Carrier O-rings

This bulletin provides instructions for identifying and replacing the adjustable bearing carrier o-rings on MTC-3203-AD02-100-300 model transfer cases. These procedures apply only to the forward output and idler adjustable bearing carriers. Figure 1.

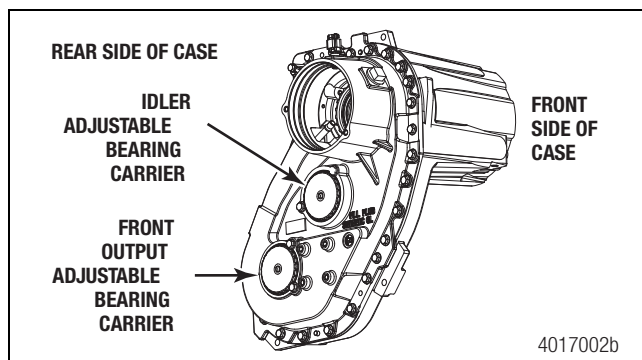

Figure 1

## Parts Required

- O-ring, Part Number 5X1508, Qty. 2 per Transfer Case
- SAE 40W Synthetic Oil
- Loctite® 242 Threadlocker

## Tools Required

- OEM Tool or 3/8" Square Drive Ratchet Wrench
- 13 mm Socket
- 10 mm Allen-Head Wrench
- Torque Wrench Capable of 55 lbs-ft (74 N·m)
- Vernier Caliper

\* If transfer case replacement is required, order FRK-20-10207.

## Inspection

These procedures apply only to MTC-3203-AD02-100-300 model variants. Use the following procedure to correctly identify affected transfer cases.

1. Locate the identification tag on the front of the transfer case. Figure 2.

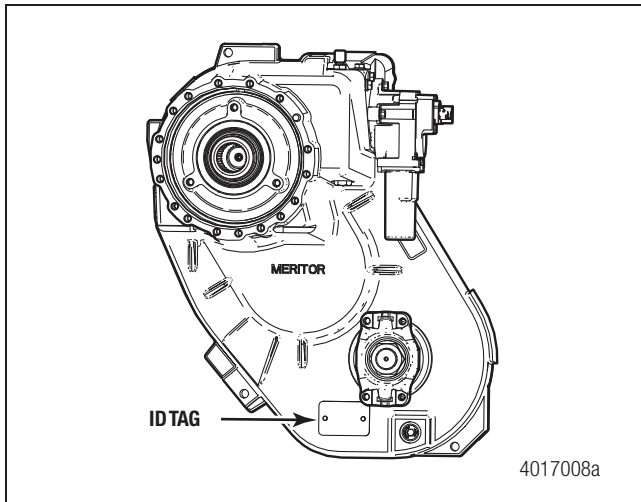

Figure 2

2. Check and record the serial number on the transfer case ID tag. Figure 3.

**NOTE:** If the ID tag is unreadable, refer to the vehicle manufacturer to identify the transfer case serial number.



Figure 3

- If the serial number is between LRS01290649 through LRS01318770: Proceed with the repair instructions in this document.

**NOTE:** If a leak is discovered, note which adjustable bearing carrier location shows evidence of the leak.

- If the serial number is outside LRS01290649 through LRS01318770: No further action is necessary.

**NOTE:** If a leak is discovered on a serial number outside the range, follow the procedures in Maintenance Manual MM-17114 to correct the leak.

## Repair Procedures

### Remove the Adjustable Bearing Carriers

1. Thoroughly clean the rear side of the transfer case prior to any disassembly.
2. Using a 10 mm allen-head wrench, remove the magnetic drain plug from the front transfer case cover and completely drain the oil. Figure 4.

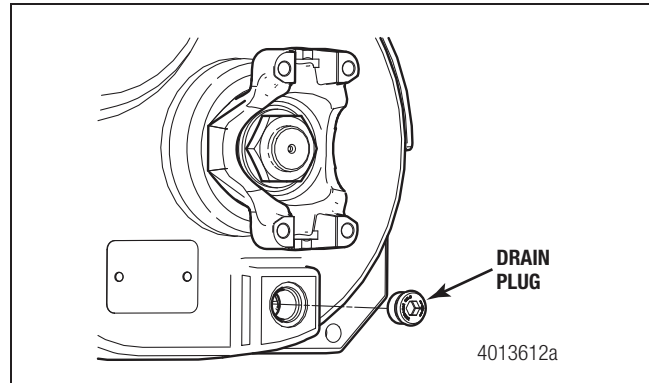

Figure 4

3. Clean the magnetic drain plug using a clean cloth. Reinstall the plug using a 10 mm allen-head wrench and tighten to 42-48 lbs-ft (57-65 N-m).

**NOTE:** Only ONE adjustable bearing carrier should be serviced at a time. Do not remove both at the same time.

4. Beginning with the front output adjustable bearing carrier, mark the exact notch/position of the case and carrier where the 13 mm retaining flange bolt is located. With the carrier to case position marked, remove the 13 mm retaining flange bolt. DO NOT rotate the carrier until AFTER the reference mark has been made. Figure 5.

**NOTE:** If a mark is not made, refer to the original witness mark where the 13 mm flange bolt was previously installed.

**NOTE:** The purpose of this step is to mark the orientation of the adjustable carrier to the case so it may be installed in the same position during reassembly.

**NOTE:** Bearing preload is set by Meritor using the adjustable bearing carriers. It is critical to proper repair that the removed carrier is threaded back to its exact original location upon reassembly.

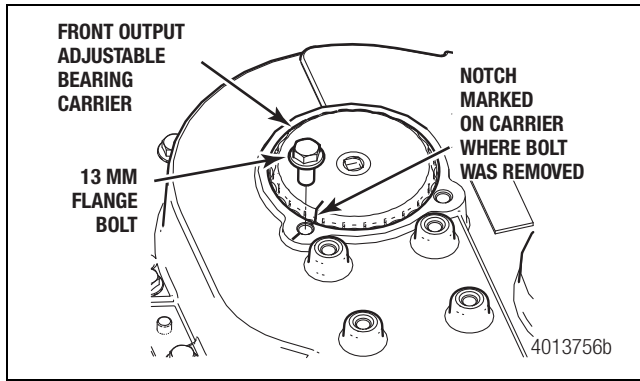

Figure 5

- Using the back of a Vernier caliper as a depth gauge, measure the distance the adjustable bearing carrier is standing off the case surface. This measurement will be used as a secondary reference during reinstallation to make sure the adjustable bearing carrier is threaded back into the same location. Figure 6.

**NOTE:** Measurement must be obtained from the same location on the carrier/case upon reassembly.

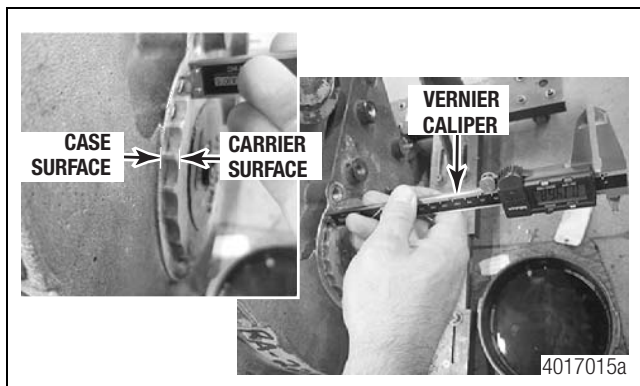

Figure 6

- With the original orientation of the adjustable bearing carrier clearly marked, place the OEM tool on the face of the bearing carrier. **Do NOT rotate the bearing carrier yet.** Figure 7. Alternately a 3/8" square drive inserted into the pipe plug on the face of the bearing carrier can be used. Figure 8.

**NOTE:** If the pipe plug breaks free before the bearing carrier begins to rotate, contact the vehicle manufacturer.

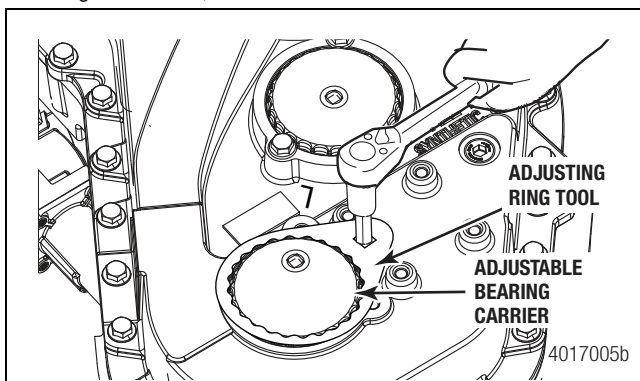

Figure 7

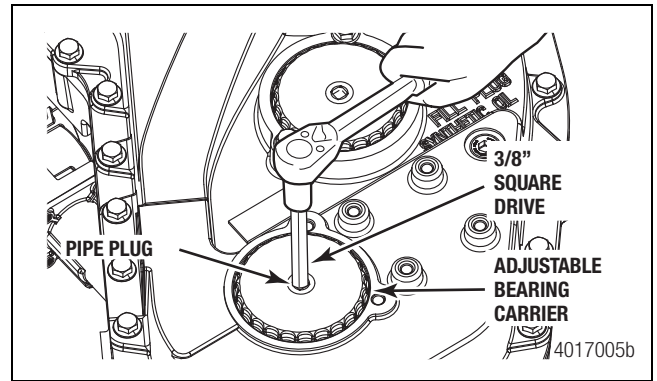

Figure 8

- With the tool in Figure 7, slowly begin to rotate the adjustable bearing carrier counter-clockwise while counting the full revolutions past your original starting mark. Figure 8.

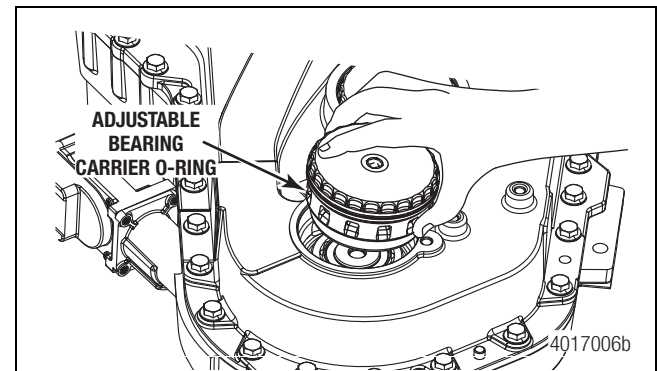

Figure 9

- Remove and discard the original o-ring from the adjustable bearing carrier. Figure 9.
- With a clean cloth, clean and inspect the case bore and adjustable bearing carrier for any damage from corrosion or debris. Figure 10 and Figure 11.

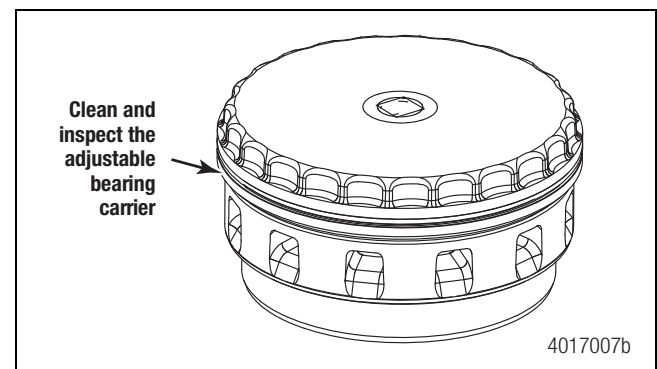

Figure 10

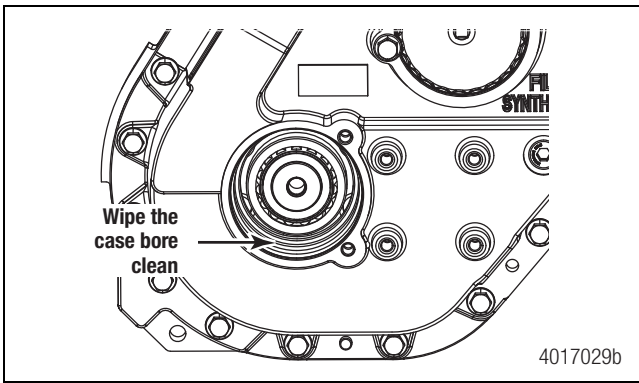

Figure 11

## Install the O-ring and Adjustable Bearing Carrier

1. Carefully install the new o-ring, part number 5X1508, into the o-ring groove on the adjustable bearing carrier. Use a small amount of SAE 40W oil as lubricant for reassembly. Figure 12.

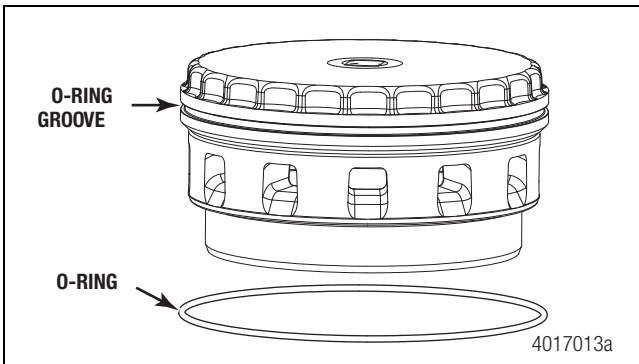

Figure 12

### ⚠ CAUTION

Use care when installing the adjustable bearing carrier to avoid damaging the o-ring.

**NOTE:** You must count the rotations of the carrier during installation to return it to its originally installed position.

2. In the clockwise direction, carefully start the threads of the adjustable bearing carrier back into the case bore, using caution to not damage the o-ring. Once the carrier threads are engaged in the case, begin to thread the carrier clockwise while counting the rotations until the carrier stops rotating past your original reference mark. Note the bearing carrier will only rotate slightly past the original reference mark. At this time, the carrier should be returned to a preloaded state. Rotate the carrier counter-clockwise slightly until the original reference mark on the carrier is lined up to your original reference mark on the case. Figures 7 & 8.

**NOTE:** Bearing preload is set by Meritor using the adjustable bearing carriers. It is critical to proper repair that the removed carrier is threaded back to its exact original location when installed.

3. At this time use the Vernier caliper to verify that the carrier depth measurement is within 0.039" (1 mm) of your original reference measurement. If the carrier is not within 0.039" (1 mm) of the original depth reference, remove the adjustable bearing carrier and reinstall. Figure 13.

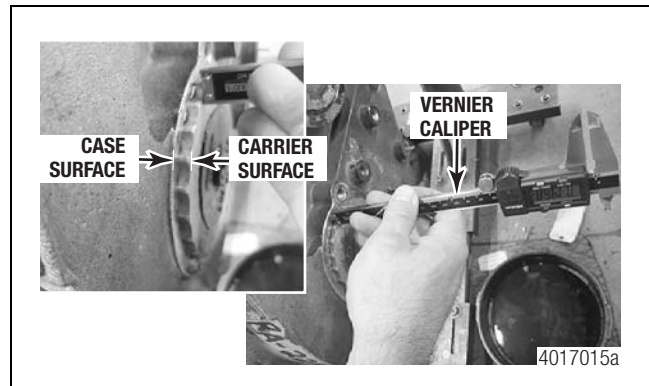

Figure 13

4. Once the adjustable bearing carrier is installed back to its original location, apply a 0.125" (3 mm) bead of Loctite 242 threadlocker around the retaining flange bolt threads approximately 0.25" (6 mm) from the end. Apply a 0.125" (3 mm) bead of Loctite 242 threadlocker across the length of the threads. Figure 14.

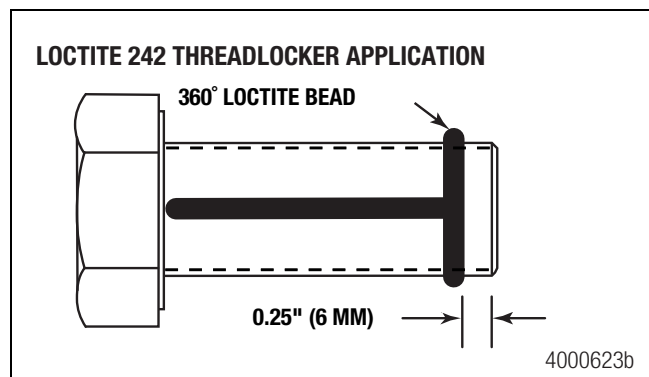
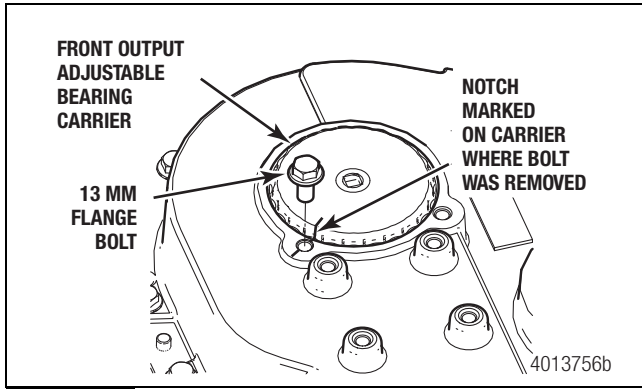

Figure 14

5. After the threadlocker is applied, reinstall the flange bolt and tighten to 43-57 lbs-ft (58-77 N-m). Figure 15.
6. Once the o-ring replacement procedure has been completed for the front output adjustable bearing carrier location, repeat the exact repair procedure for the adjustable bearing carrier at the idler location.
7. Using a 10 mm allen-head wrench, remove the transfer case fill plug and fill with new SAE 40W synthetic oil. Reinstall the fill plug and tighten to 42-48 lbs-ft (57-65 N-m).



**Figure 15**



**Meritor Heavy Vehicle Systems, LLC**  
2135 West Maple Road  
Troy, MI 48084 USA  
866-OnTrac1 (668-7221)  
meritor.com

Information contained in this publication was in effect at the time the publication was approved for printing and is subject to change without notice or liability. Meritor Heavy Vehicle Systems, LLC, reserves the right to revise the information presented or to discontinue the production of parts described at any time.

Copyright 2020  
Meritor, Inc.  
All Rights Reserved

Printed in USA

TP-2043  
Revised 03-20