

Service Alert

Mazda North American Operations
Irvine, CA 92618-2922



Subject: "IN-VEHICLE NETWORK MALFUNCTION" INSTRUMENT CLUSTER WARNING MESSAGE	Service Alert No.: SA-029/20
	Last Issued: 04/08/2020

BULLETIN NOTES

This service alert supersedes the previously issued service alert listed below. The changes are noted in Red text.

Previous Service Alert:	Date(s) Issued:
SA-029/20	02/25/20
SA-014/19	09/05/19 and 04/03/19

APPLICABLE MODEL(S)/VINS

2019-2020 Mazda3
2020 CX-30

DESCRIPTION

Some customers may experience a "IN-VEHICLE NETWORK MALFUNCTION" warning message in the instrument cluster with one or more of the following DTC's stored:

- B119F:01 TCU - Tel antenna No. 1 malfunction
- B1252:87 TCU - Communication error with connectivity master unit (CMU)
- U0156:00 VCM - Communication error with connectivity master unit (CMU)
- U0156:00 BCM - Communication error with connectivity master unit (CMU)
- U0198:00 BCM - Communication error with emergency call unit
- U212D:00 BCM - Communication error with light control module (RH)
- U3000:00 TCU - Telematics communication unit internal malfunction
- **Low Battery DTCs**

CONSUMER NOTICE: The information and instructions in this bulletin are intended for use by skilled technicians. Mazda technicians utilize the proper tools/equipment and take training to correctly and safely maintain Mazda vehicles. These instructions should not be performed by "do-it-yourselfers." Customers should not assume this bulletin applies to their vehicle or that their vehicle will develop the described concern. To determine if the information applies, customers should contact their nearest authorized Mazda dealership. Mazda North American Operations reserves the right to alter the specifications and contents of this bulletin without obligation or advance notice. All rights reserved. No part of this bulletin may be reproduced in any form or by any means, electronic or mechanical---including photocopying and recording and the use of any kind of information storage and retrieval system ---without permission in writing.

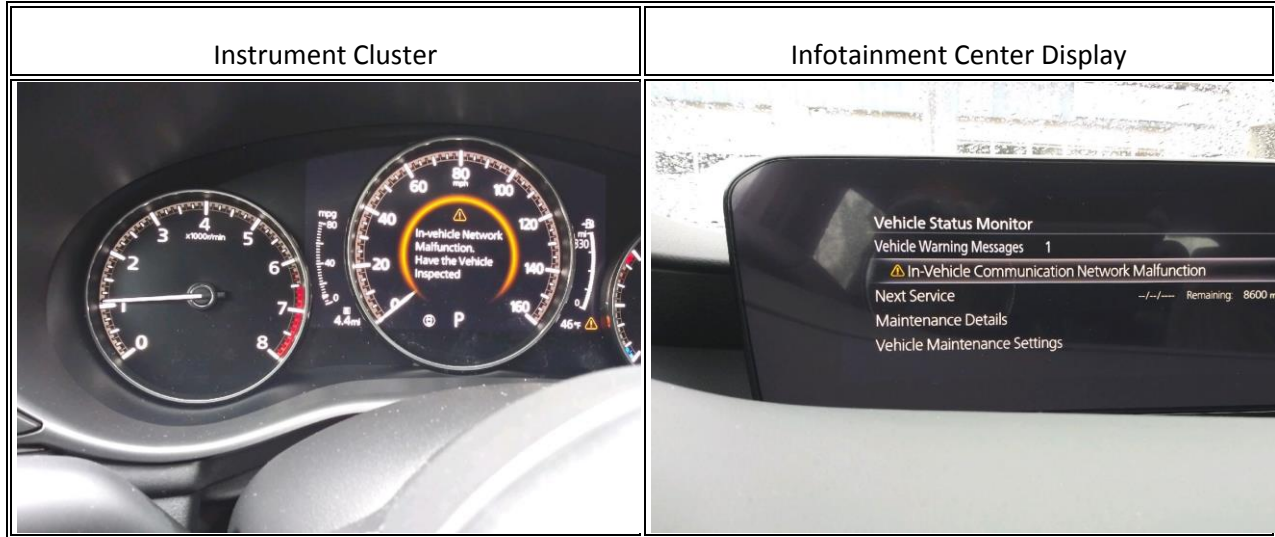

REPAIR PROCEDURE

1. Verify customer concern.

2. Connect MDARS.

NOTE: Only use MDARS to scan for DTC's. If IDS is used, P0602 (PCM programming error) will falsely set.

Is the TCU shown (red or green) on the MDARS main screen?

- Yes - Go to the next step.
- No - Go to **Method For Recovering Missing TCU**, then go to next step.

3. Check for:

- Missing fuses
- Blown fuses
- Correct fuse amperage

CONSUMER NOTICE: The information and instructions in this bulletin are intended for use by skilled technicians. Mazda technicians utilize the proper tools/equipment and take training to correctly and safely maintain Mazda vehicles. These instructions should not be performed by "do-it-yourselfers." Customers should not assume this bulletin applies to their vehicle or that their vehicle will develop the described concern. To determine if the information applies, customers should contact their nearest authorized Mazda dealership. Mazda North American Operations reserves the right to alter the specifications and contents of this bulletin without obligation or advance notice. All rights reserved. No part of this bulletin may be reproduced in any form or by any means, electronic or mechanical---including photocopying and recording and the use of any kind of information storage and retrieval system ---without permission in writing.

4. Are any DTC(s) stored?

- Yes - See table below:
- No - Contact hotline for latest repair information.

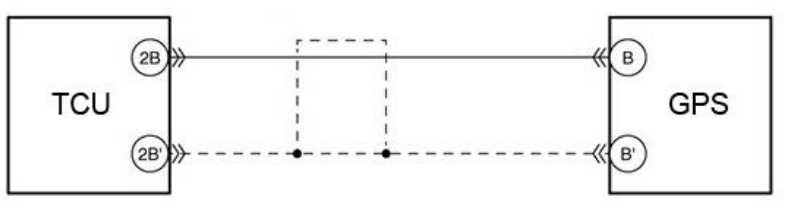
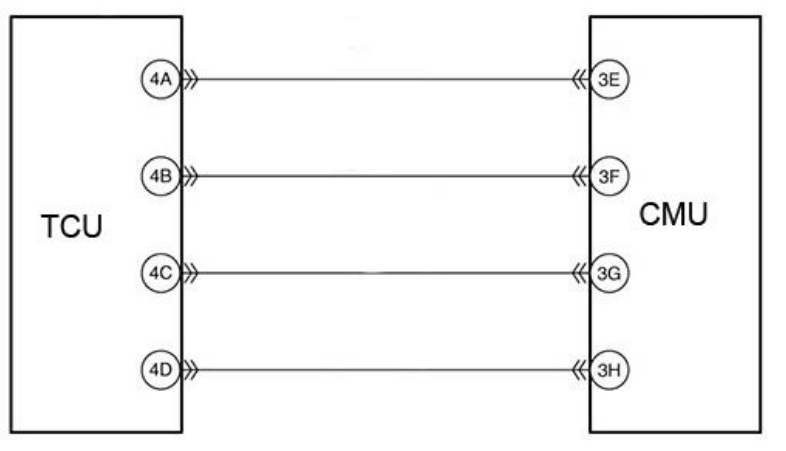
DTC	Action
B119F:01	<p>1. Check GPS antenna connection.</p> <p>1. GPS connection is good - No further repairs needed. TSB repair is coming soon. Inform the customer that Mazda is aware of the issue and is working on a repair. Release the vehicle to the customer.</p> <p>2. GPS connection is bad - Repair GPS antenna connection.</p> 
B1252:87	<p>1. Check USB cable connections between TCU and CMU.</p> 
U0156:00	<p>1. Refer to the instructions on MGSS.</p> <p>1. Mazda3 DTC U0156:00 [BODY CONTROL MODULE (BCM)]</p> <p>2. CX-30 DTC U0156:00 [BODY CONTROL MODULE (BCM)]</p>

CONSUMER NOTICE: The information and instructions in this bulletin are intended for use by skilled technicians. Mazda technicians utilize the proper tools/equipment and take training to correctly and safely maintain Mazda vehicles. These instructions should not be performed by "do-it-yourselfers." Customers should not assume this bulletin applies to their vehicle or that their vehicle will develop the described concern. To determine if the information applies, customers should contact their nearest authorized Mazda dealership. Mazda North American Operations reserves the right to alter the specifications and contents of this bulletin without obligation or advance notice. All rights reserved. No part of this bulletin may be reproduced in any form or by any means, electronic or mechanical---including photocopying and recording and the use of any kind of information storage and retrieval system ---without permission in writing.

<p>U0198:00</p>	<p>1. Check USB cable connections between TCU and CMU.</p>
<p>U212D:00</p>	<p>1. Refer to the instructions on MGSS. 1. Mazda3 DTC U212D:00 [BODY CONTROL MODULE (BCM)] 2. CX-30 DTC U212D:00 [BODY CONTROL MODULE (BCM)]</p>
<p>U3000:00</p>	<p>1. Replace TCU. Refer to the instructions on MGSS. 1. Mazda3 TELEMATICS COMMUNICATION UNIT REMOVAL/INSTALLATION. 2. CX-30 TELEMATICS COMMUNICATION UNIT REMOVAL/INSTALLATION.</p>
<p>Other DTC's</p>	<p>Refer to the instructions on MGSS.</p>
<p>Low Battery with or without DTC</p>	<p>Reset KAM</p>

5. Verify repair.

CONSUMER NOTICE: The information and instructions in this bulletin are intended for use by skilled technicians. Mazda technicians utilize the proper tools/equipment and take training to correctly and safely maintain Mazda vehicles. These instructions should not be performed by "do-it-yourselfers." Customers should not assume this bulletin applies to their vehicle or that their vehicle will develop the described concern. To determine if the information applies, customers should contact their nearest authorized Mazda dealership. Mazda North American Operations reserves the right to alter the specifications and contents of this bulletin without obligation or advance notice. All rights reserved. No part of this bulletin may be reproduced in any form or by any means, electronic or mechanical---including photocopying and recording and the use of any kind of information storage and retrieval system ---without permission in writing.

Method For Recovering Missing TCU

a.	ID vehicle using MDARS.
b.	IG OFF.
c.	Refresh DTC.
d.	IG ON while refreshing DTC.
e.	TCU now appears. Go to step 3.

TCU appears

CONSUMER NOTICE: The information and instructions in this bulletin are intended for use by skilled technicians. Mazda technicians utilize the proper tools/equipment and take training to correctly and safely maintain Mazda vehicles. These instructions should not be performed by "do-it-yourselfers." Customers should not assume this bulletin applies to their vehicle or that their vehicle will develop the described concern. To determine if the information applies, customers should contact their nearest authorized Mazda dealership. Mazda North American Operations reserves the right to alter the specifications and contents of this bulletin without obligation or advance notice. All rights reserved. No part of this bulletin may be reproduced in any form or by any means, electronic or mechanical---including photocopying and recording and the use of any kind of information storage and retrieval system ---without permission in writing.