



# Service Bulletin

Bulletin No.: 19-NA-184

Date: March, 2020

## TECHNICAL

**Subject: Front Exterior Lighting Malfunction**

Brand:	Model:	Model Year:		VIN:		Engine:	Transmission:
		from	to	from	to		
Cadillac	XT4	2019	2019			All	All

<b>Involved Region or Country</b>	North America, Middle East, Israel
<b>Additional Options (RPOs)</b>	Equipped with LAMP-FRT TURN SIGNAL, LED (UGC) and Excluding (UGC)
<b>Condition</b>	Some customers may comment that the low beam lamps are <b>always</b> on, and cannot be turned off. They also may note that <b>all</b> of the following lamp functions are inoperative: <ul style="list-style-type: none"> <li>• Turn signal</li> <li>• Daytime running lamps (DRL)</li> <li>• High beam lamps</li> <li>• Park lamps</li> <li>• Hazards</li> </ul>
<b>Cause</b>	The cause of the condition may be that a failure mode in the headlamp assembly module has occurred. The software error puts the headlamp in a Fail-Safe Mode (low beam only) and disables other lamp functions.
<b>Correction</b>	Depending on whether the vehicle is equipped WITH or Excluding (UGC), proceed by validating the steps in the appropriate Service Procedure below.

### Service Procedure

#### XT4 Equipped with UGC

- Confirm that the low beam lamps are **always** on and cannot be switched off.
- Confirm that the DRL, high beams and parking lamps are ALL **inoperative**.
- Confirm that the turn signal lamps are **inoperative** and that the turn signal is operating as intended on the IPC. Even though the turn signal is not functioning, it will appear to the customer that it is functioning correctly.

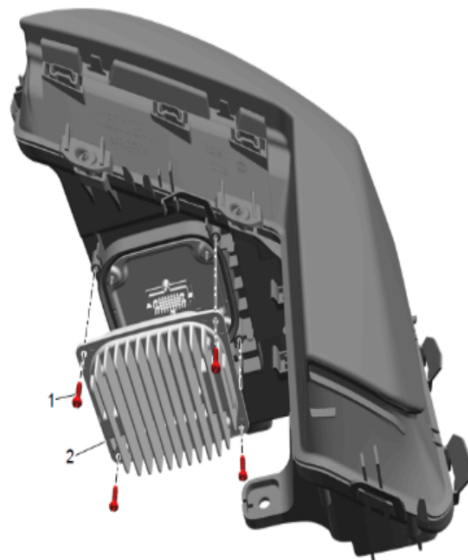

5393772

**If all the prior criteria is met, replace the affected right and/or left headlamp automatic control module(s) (2).** Refer to *Headlamp Automatic Control Module Replacement* in SI.

**XT4 Equipped Excluding UGC**

- Confirm that the low beam lamps are **always** on and cannot be switched off.
- Confirm that the DRL, high beams and parking lamps are **ALL inoperative**.
- Confirm that the turn signal lamps are **operative**.

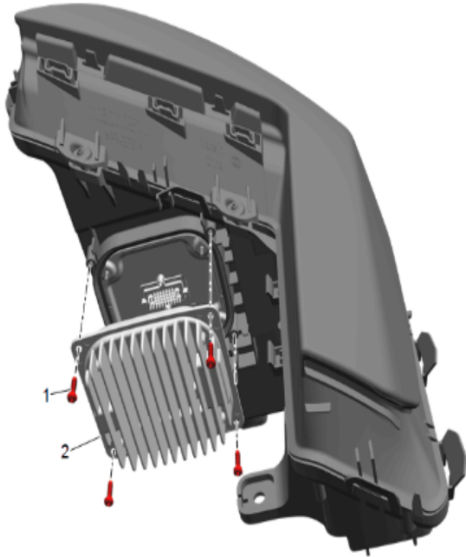

5393772

If all the prior criteria is met, replace the affected right and/or left headlamp automatic control module(s) (2). Refer to *Headlamp Automatic Control Module Replacement* in SI.

<b>Version</b>	1
<b>Modified</b>	Released March 24, 2020

**Parts Information**

Causal Part	Description	Part Number	Qty
X	MODULE ASM-HDLP AUTO CONT	84761764	1, or 2, as needed
		84761765	
		84761766	
		84761767	

**Warranty Information**

For vehicles repaired under the Bumper-to-Bumper coverage (Canada Base Warranty coverage), use the following labor operation. Reference the Applicable Warranties section of Investigate Vehicle History (IVH) for coverage information.

Labor Operation	Description	Labor Time
2086018*	Headlamp Automatic Control Module Replacement	3.4 hrs
Add	Replace Headlamp Automatic Control Module on Opposite Side	0.2 hr

\*This is a unique Labor Operation for bulletin use only.

