

04/17/2020
CAL FTL 32-004

Subject: 80KSI Frame Reinforcement Installation

Models Affected: Specific 2020 model year Freightliner M2 vehicles manufactured between May 28, 2019 and October 06, 2019 equipped with 80KSI frame rails and an Airliner 21,000 lb rear suspension

DS Services,

Our records indicate that you are the owner of certain vehicles, and therefore DTNA has decided to share the following documentation with you.

04/17/2020
CAL FTL 32-004

Work Instructions

Subject: 80KSI Frame Reinforcement Installation

Models Affected: Specific 2020 model year Freightliner M2 vehicles manufactured between May 28, 2019 and October 06, 2019 equipped with 80KSI frame rails and an Airliner 21,000 lb rear suspension

Parts

Parts Required		
Part Number	Part Description	Quantity
23-09114-000	WASHER-HRDN,0.69X1.31X.177,ZN	16
23-13179-110	NUT-HEX,PT,5/8-11,C,ZC,.559	8
23-09444-275	SCREW-CAP,5/8-11X2.75GR8PO.403	2 (Bump stop)
23-09444-200	SCREW-CAP,5/8-11X2.00GR8PO.403	2 (Shock bracket)
23-09444-500	SCREW-CAP,5/8-11X5.00GR8PO.403	2 (Track rod frame bracket)
23-09444-400	SCREW-CAP,5/8-11X4.00GR8PO.403	2 (Track rod axle tower)
16-14540-000	PLT-BKG,A/L,6,28/90/23.9D344	1
680 990 04 40	WASHER-FLAT, HARDENED,40X17.5X6	1

Table 1, Parts Required

Work Instructions

Replace the existing reinforcement plate located at the rear suspension track rod frame bracket with a larger reinforcement plate as outlined in the following instructions.

1. Park the vehicle on a level surface, set the parking brakes, and chock the tires.
2. Put the transmission in neutral. Build the air pressure to at least 100 psi. Set the Airliner rear suspension to its normal ride height. Shut down the engine.
3. Remove the rear suspension axle stop from the right-hand frame rail.
4. Disconnect the transverse torque rod from the axle tower bracket, then remove the transverse torque rod and bracket from the inside of the right-hand frame rail.
5. Remove the existing reinforcement plate and discard it.
6. Remove the fasteners that attach the right-hand shock mounting-bracket to the frame.
7. Thoroughly clean the inside and outside of the right-hand frame rail between the air spring and suspension crossmember.
8. Align the inner reinforcement plate (16-14540-000) with the shock bracket mounting holes on the inside of the right-hand frame, then attach the shock mounting bracket to the frame and inner reinforcement plate using the two 2 in long 5/8 in bolts, nuts, and washers. See [Fig. 1](#). Tighten the bolts hand tight only.

04/17/2020
CAL FTL 32-004

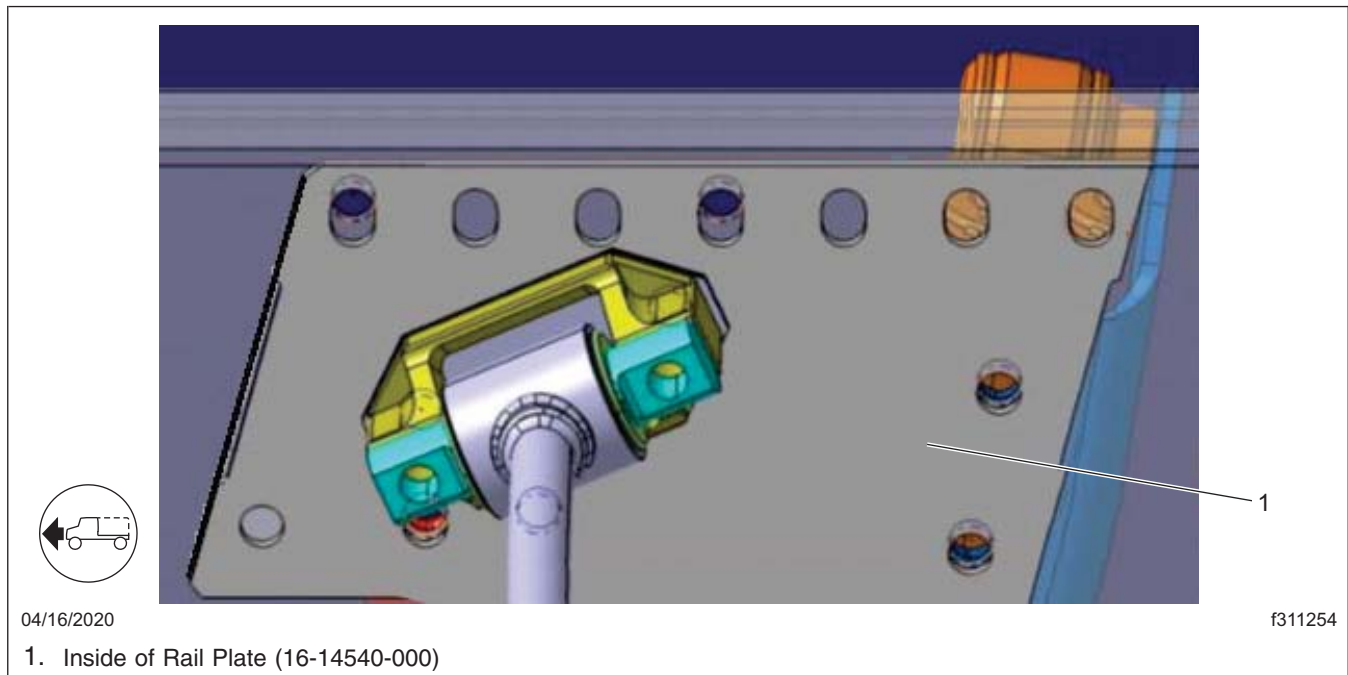

Fig. 1, View From Inside of Right-Hand Rail

9. Attach the bump stop through the two lower mounting holes using the two 2-3/4 in long 5/8 in bolts, nuts and washers. Tighten the bolts hand tight only.
10. Attach the transverse torque rod and bracket using the two 5 in long 5/8 in bolts, nuts and washers. Insure the washer (680 990 04 40) is installed as shown in **Fig. 2**.

04/17/2020
CAL FTL 32-004

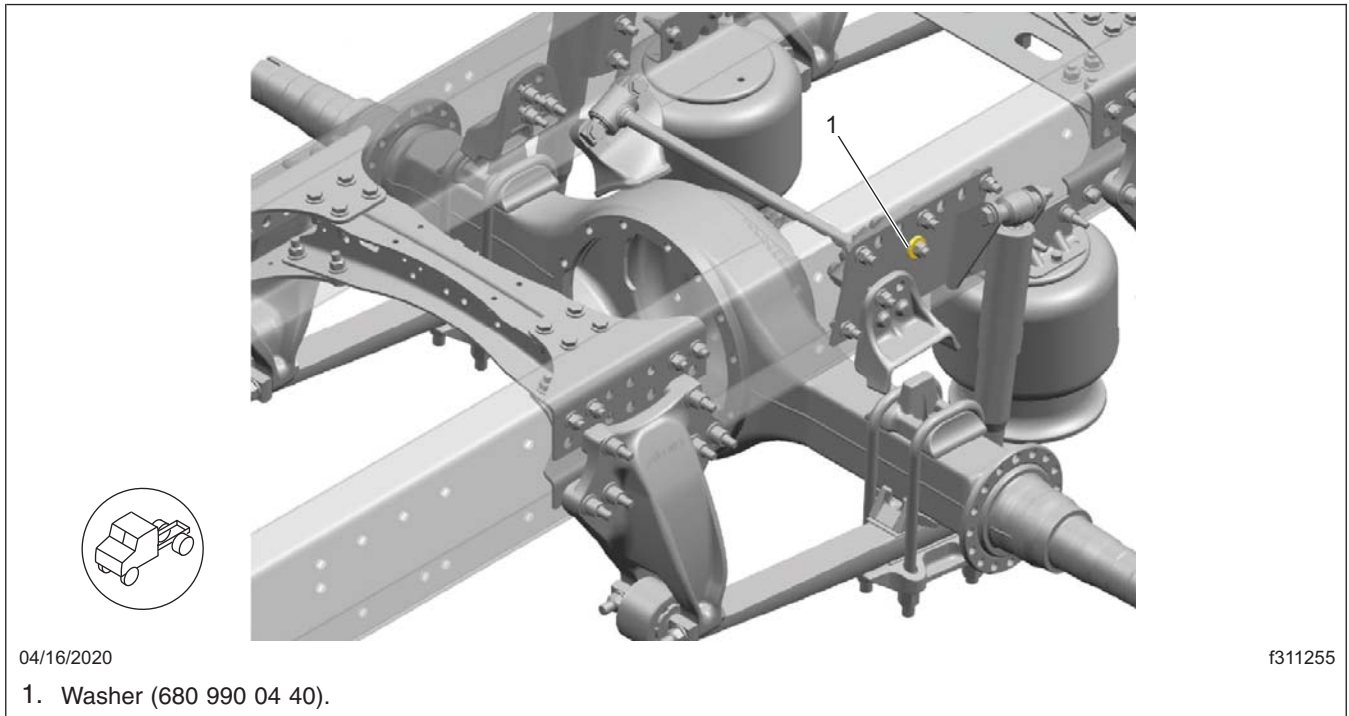

Fig. 2, View of Installed Washer

11. Attach the transverse torque rod to the axle tower using the two 4 in long 5/8 in bolts, nuts, and washers.
12. Torque the 5/8 in fasteners from the nut side to 128 lbf·ft (174 N·m).

Warranty

This procedure is warrantable only if the described condition exists and the repair is performed within the applicable base or extended coverage warranty period. If a failure is not found, this procedure is considered preventive and warranty does not apply.

Normal warranty applies. See [Table 2](#) for OWL VMRS codes and labor allowance information. Enter this CAL bulletin number in the claim story as you would do for a Service Bulletin warranty claim.

OWL VMRS Codes and Labor Allowance					
Primary Failed Part	Component Code	Cause Code	SRT Code	Description	Time: Hours
681 328 15 85	016-005-118	28	623-5015A	TORQUE ROD MTG BRKT, W/DRILLING	4.5

Table 2, OWL VMRS Codes and Labor Allowance