



# Ferrari North America Technical Information

Date: March 2020  
Bulletin #: 2657  
Campaign #:  
Supersedes:  
Section: 10

Model: 812 GTS

Subject: Installation of front and rear license plate holders

Please find herein the instructions for fitting the front and rear license plates on the aforementioned model.

The vehicle is shipped from the factory with a specific kit for the destination market for installing the front and rear license plate holders.

The market-specific kit consists of:

- Front license plate holder
- Rear license plate holder;
- Bag containing fastener hardware for installing license plate holders.

The front (Fig. 1) and rear (Fig. 2) license plate holders differ depending on the market, but must always be installed in the same position: The license plate holder must be installed precisely in the center of the front and rear bumper.

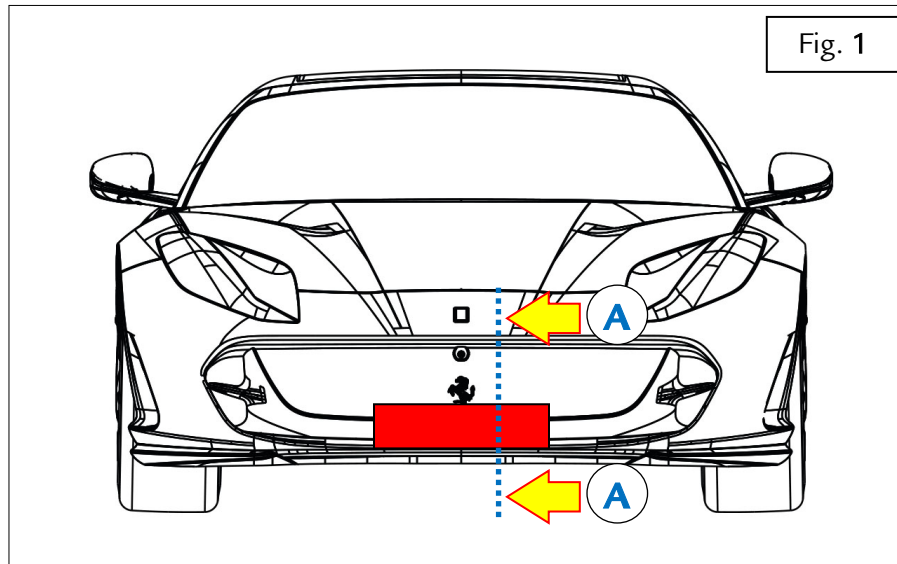

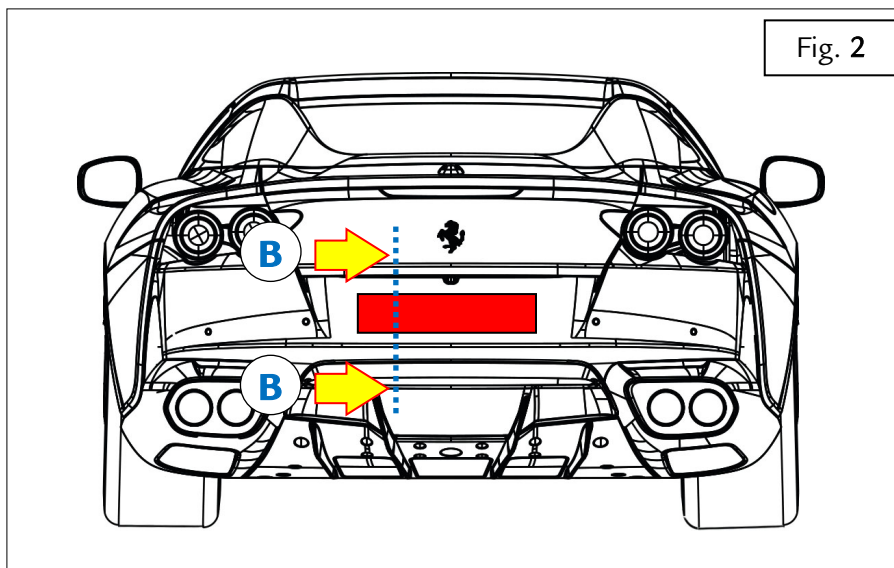

The file denominated “Dima\_Portatarga\_USA” attached to this Technical Information contain the templates which must be used to install the license plate holders. The following table indicates the correct file for each market.

## COMPLETE FRONT LICENSE PLATE HOLDER (Cross section A – Fig. 1)

When fitting the complete front license plate holder:

- the license plate holder must be centered perfectly with the centerline of the front bumper;
- the bottom of the license plate holder must be perfectly parallel with the ground;

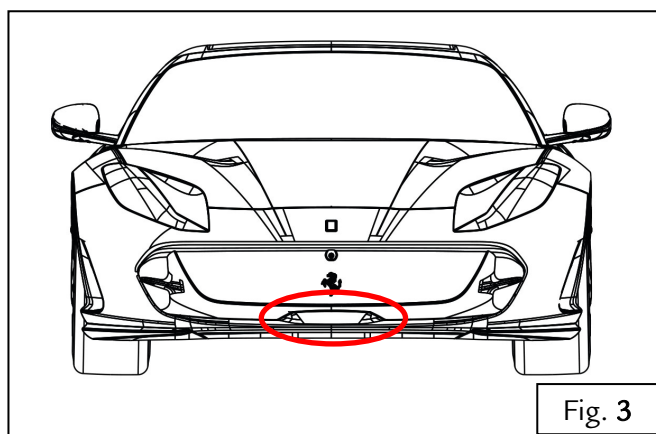

- Identify the mounting position for the complete front license plate holder on the front bumper –Fig. 3.
- Print the attached document **Dima\_Portatarga\_USA**, ensuring that the option 'Scale to paper size' is set to “No Scaling” (DO NOT RESIZE THE PAGE).



# Ferrari North America

- After printing the document, use a ruler to check that the measurement indicated is correct, and then cut out and join the two parts of the template.
- On the front bumper, identify the division between the painted bodywork and the matte black zone, indicated by the dotted yellow line in Fig. 7. The upper edges of the template must be placed against this division on both sides.  
Note: the European version of the template is shown in Fig. 4 as an example.
- Place the template on the vehicle, centering horizontally and with the upper edges precisely against the division between the painted bodywork and the matte black zone on the bumper.

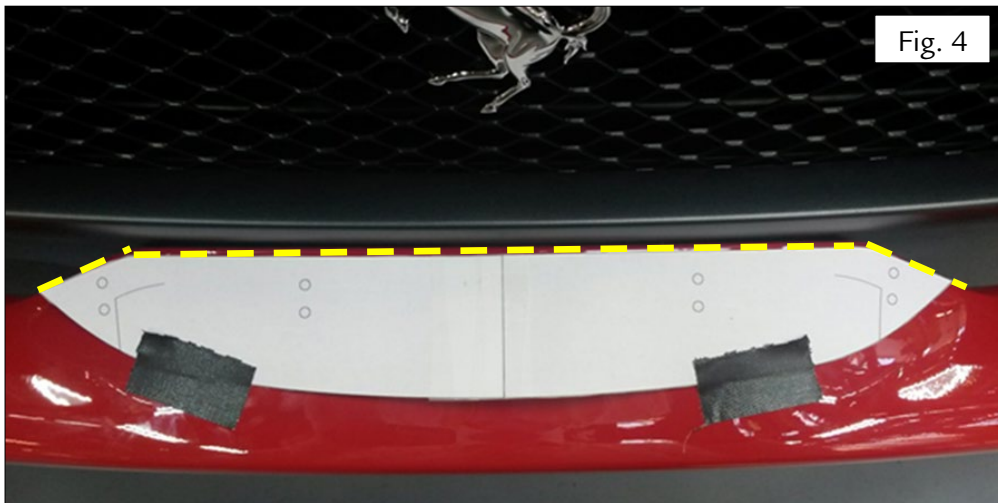

- Check that the template is positioned correctly on the front bumper, and that all the conditions indicated above are met.
- Using a drill with a suitable bit, drill 8 holes in the positions indicated on the template.
- Place the complete front license plate holder over the holes drilled in the previous step.
- Fasten the license plate holder with the rivets included in the kit.



## REAR LICENSE PLATE HOLDER (Cross section B – Fig. 2) –

When fitting the rear license plate holder (2), ensure that the following conditions are met:

- the license plate holder must be centered perfectly with the centerline of the rear bumper;
- the distance Z (shown in Fig.5) must be 34mm.

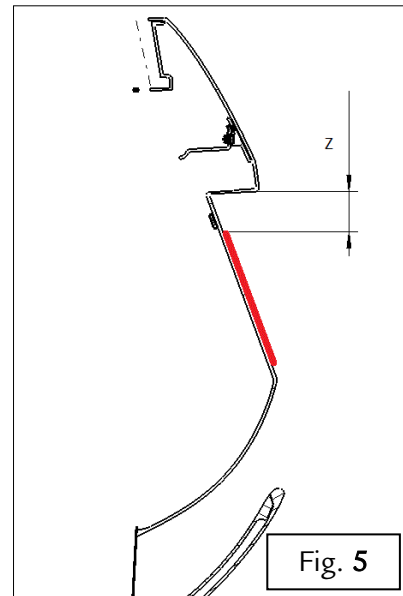

- Fit the license plate holder as indicated, aligning the top edge in the correct position in accordance with the distance Z. Fig.6

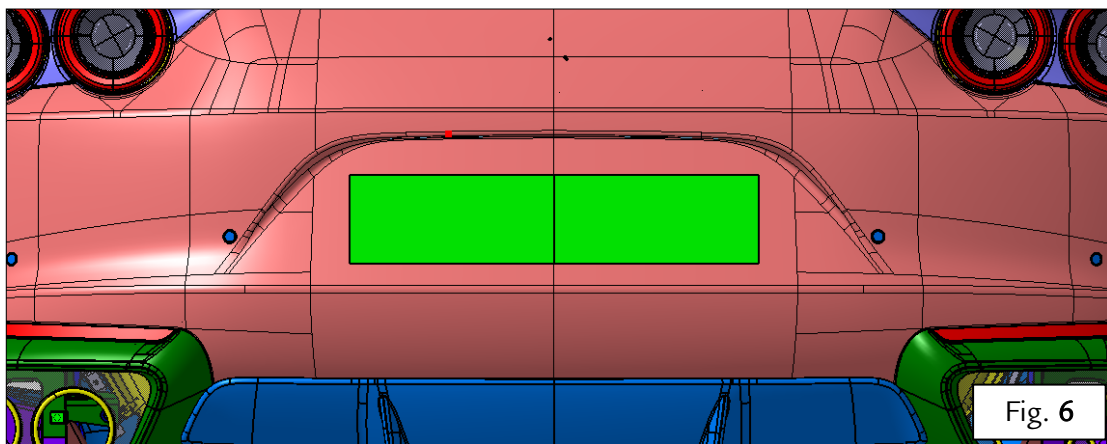

- With the license plate holder positioned correctly as described, mark the positions of the four mounting holes on the license plate holder itself.
- Using a drill with a suitable bit, drill four holes in the positions marked.



# Ferrari North America

- Place the rear license plate holder over the holes drilled in the previous step.
- Fasten the license plate holder with the rivets included in the kit.

Thank you for your co-operation.

USA VERSION TEMPLATE

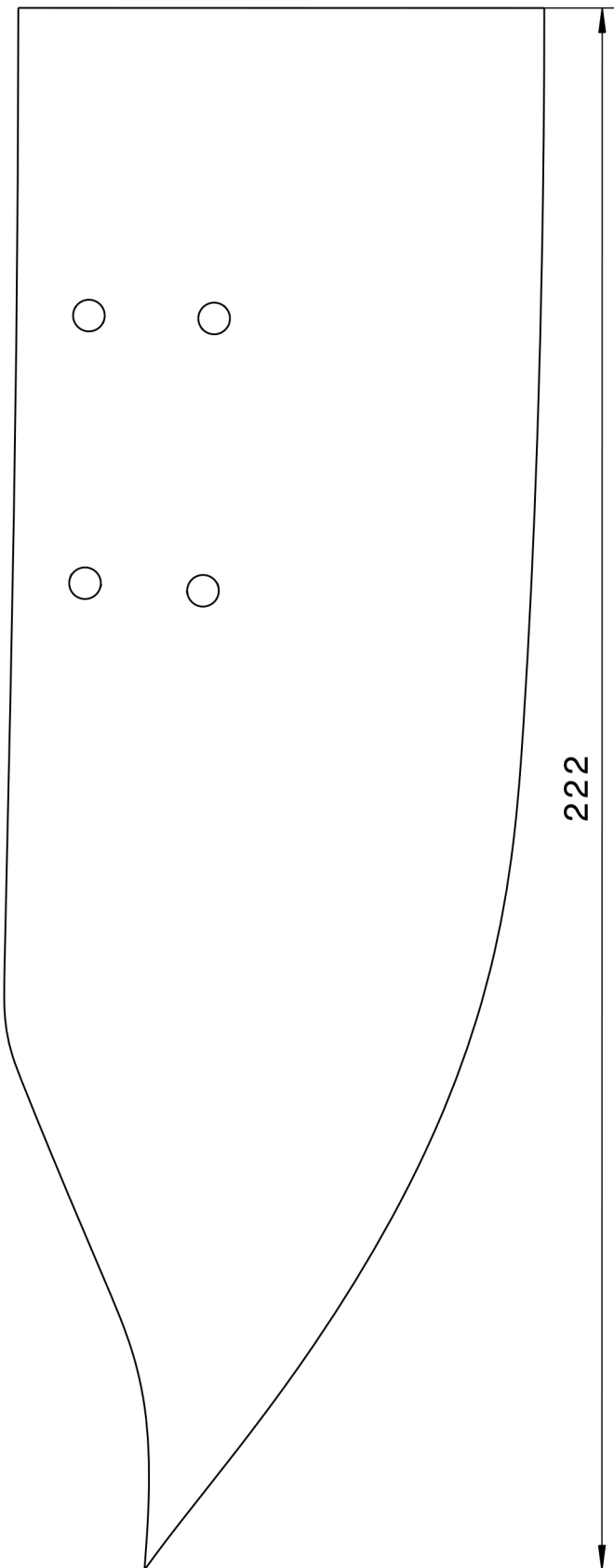

Left Side  
Dimension in mm

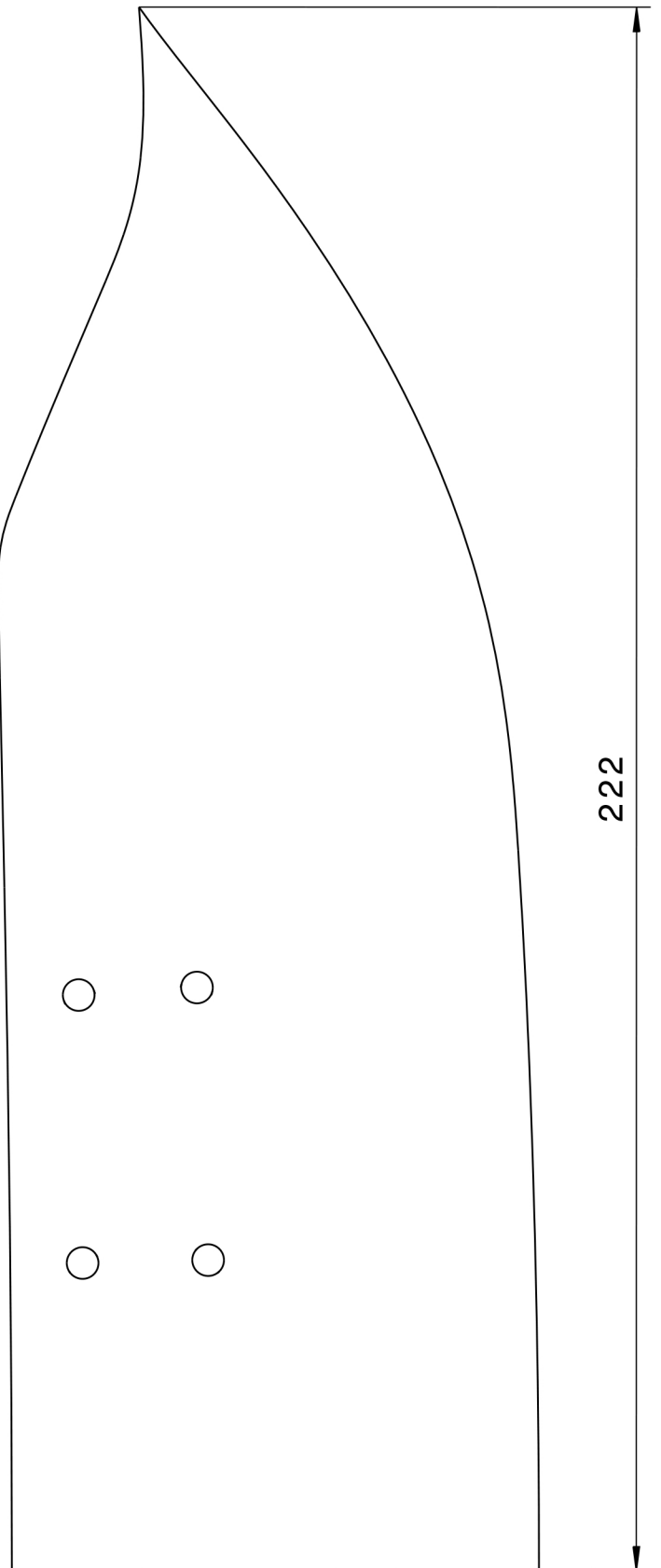

Right Side  
Dimension in mm