



Technical Service Bulletin

GROUP HVAC	NUMBER 20-HA-001H
DATE MARCH, 2020	MODEL(S) Multiple HEV, PHEV, and EV Models

SUBJECT: ELECTRIC COMPRESSOR BODY
AND INVERTER REPLACEMENT GUIDELINES

This TSB supersedes TSB 19-HA-001H to revise the available service parts configuration.

Description: This bulletin provides additional service diagnostic information and repair procedures related to electric A/C compressors equipped in hybrid electric vehicles, plug-in hybrid electric vehicles, and electric vehicles.

Refer to the applicable Shop Manual HVAC section of the vehicle, and then follow the procedures outlined in this bulletin whenever a vehicle with the following symptom(s) are being diagnosed:

- A/C does not get cold enough or A/C does not operate at all.
- A/C compressor operates with very high abnormal noise.
- Related Diagnostic Trouble Code (DTC) is present.

⚠ WARNING

Be sure to read and follow the sections listed below from the applicable Shop Manual before doing any work related with the high voltage system:

- General Safety Information and Caution
- High Voltage Shut-Off Procedures

Failure to follow the safety instructions may result in serious electrical injuries.

Component Overview:

The electric A/C compressor assembly has 2 major segments that are tasked with a specific function.

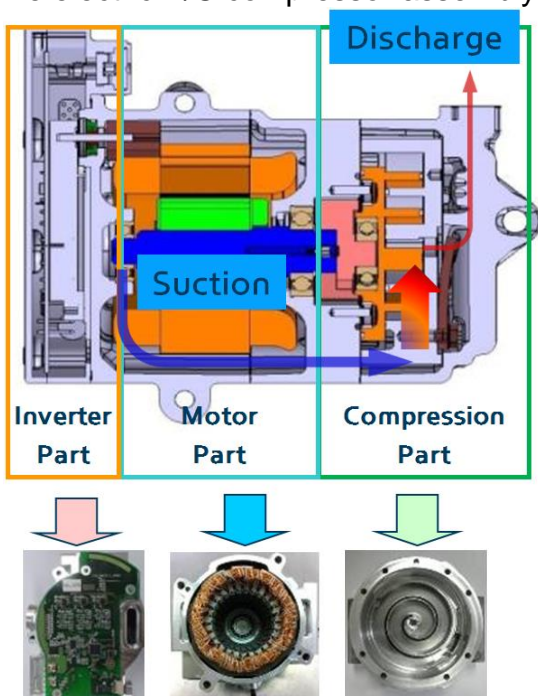

- **INVERTER**

- The inverter converts direct current to 3-phase alternating current to control the compressor speed for supporting the required cooling or heating (if equipped with a heat pump system) demand.

- Main Parts: PC Board, High voltage capacitor, Power switch

- **COMPRESSOR BODY**

- The motor is a brushless DC type and converts the electric energy into mechanical motion.
 - Main Parts: Stator, Rotor, Insulator, Magnet
- The compressor is an orbital scroll that is rotated by the motor and compresses the refrigerant against the fixed scroll.
 - Main Parts: Fixed/Orbital Scroll, Anti-rotating mechanism, Shaft/Bushing

Circulate To: General Manager, Service Manager, Parts Manager, Warranty Manager, Service Advisors, Technicians, Body Shop Manager, Fleet Repair

NOTICE

If there's an issue with other parts of the high voltage system (such as the battery pack, BMS, power line, fuse, etc.), then it may affect the proper operation of the compressor.

Troubleshooting Flow Diagram:

Follow the information shown below to determine the proper diagnosis and repair procedure.

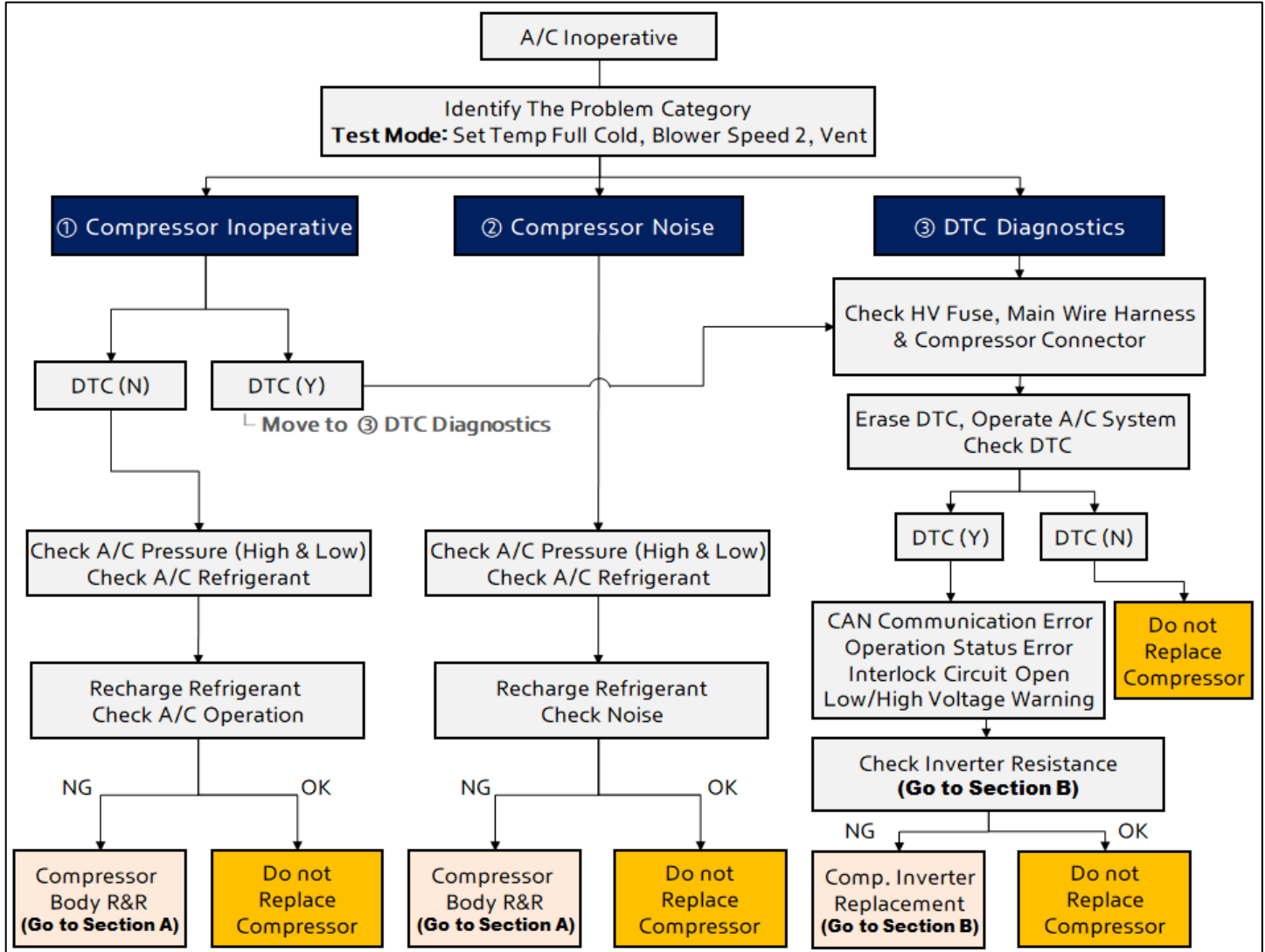

Service Procedure - Section A:

1. Remove the suction pipe fitting from compressor to gain access to the suction port.
2. Inspect the copper wire and white thread inside the suction port for **burnt colored contamination**.

Inspection Results – Next Steps	
Contamination: Replace the Compressor Body	No Contamination: Go to Section B if other issues exist.



NG 

OK 

NOTICE

Visual inspection is not possible for 11-15MY (YFE) Sonata HEV. Replace the compressor body.

Service Procedure - Section B:

1. If there any BMS related codes unrelated to the A/C system, resolve the BMS related issues first and then retest the A/C system function again to determine if further diagnosis is necessary.
2. Inspect the 30A High Voltage DC Protection Fuse if any of the following symptoms are present and then retest the A/C system.
 - Compressor will not operate (A/C is not cold).
 - DTC set in DATC system (B1801 or B1695).

NOTICE

- **30A High Voltage DC Fuse is located in the HPCU.**
- **Shut off High Voltage before inspecting the DC Fuse.**

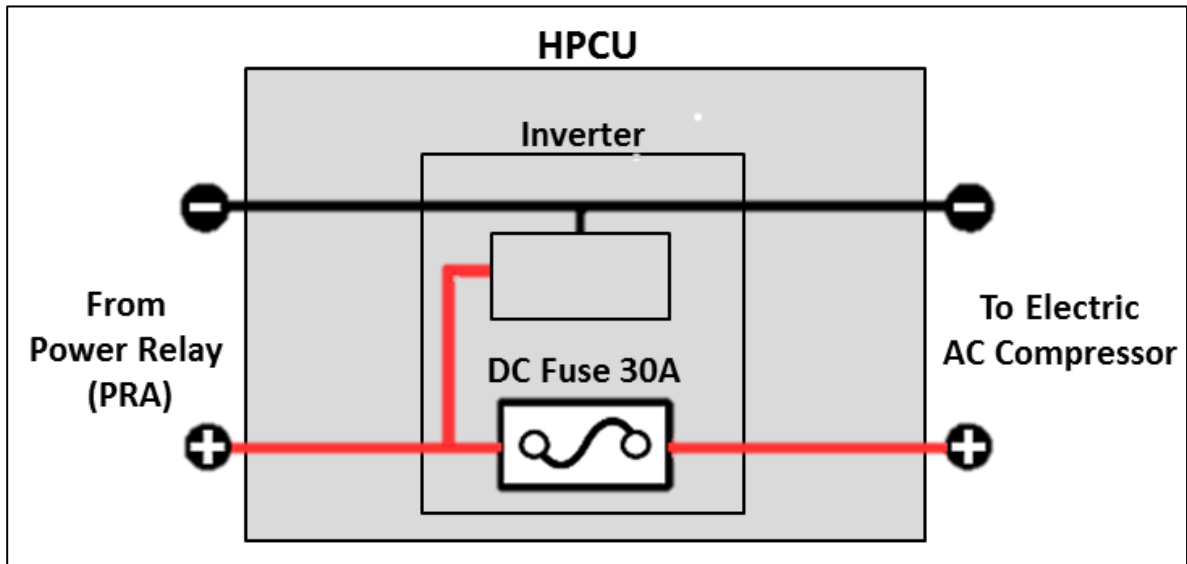

3. Inspect and diagnose the A/C system according to the DTC issues listed below.

DTC Issue List		Related DTC Category
1	CAN Communication Error	B1695, B169588
2	Operation Status Error	B1696, B169688, B1807
3	Interlock Circuit Open	B2470, B247013
4	Low Voltage Warning	B1821, B182188, B1801
5	High Voltage Warning	B1822, B182288, B1802

- Refer to the following page for the inverter connector and harness pin resistance inspection procedures.

4. Check the resistance at the electric A/C compressor High and Low Voltage connectors.
 - **Operation Status Error** can be the result of internal inverter damage.
 - Check the High Voltage Connector resistance.
 - Replace the inverter if resistance is out of spec and then retest the A/C system.

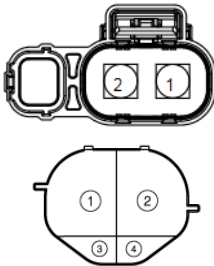
High Voltage Connector - Resistance Value Checking		
Inspect High Voltage input and ground resistance between terminals ① and ②. <ul style="list-style-type: none"> ➤ OK → Over 100Ω (Open) ➤ NG → Below 100Ω 		(Connector Varies By Model) <ul style="list-style-type: none"> ① HV High Voltage IG ② HV High Voltage GND ③ External Interlock (-) ④ External Interlock (+)

- **CAN Communication Error** can be the result of poor contact at the Low Voltage Connector.
 - Inspect the connector for (bent pin, poor contact, damage, etc.) and then inspect the Low Voltage Connector resistance.
 - Retest A/C operation after checking or replace the inverter if resistance is out of spec.

NOTICE

Refer to the correct **CAN High / CAN Low** resistance specifications after confirming the **Inverter Type** by part number and **VIN** production date listed in the **Parts Information** table.

- **Interlock Circuit Open** can be the result of poor contact at the Low Voltage Connector.
 - Inspect the connector proper connection (complete insertion) and then inspect the Low Voltage Connector interlock resistance after connecting the High Voltage Connector.
 - Retest A/C operation after checking or replace the inverter if resistance is out of spec.

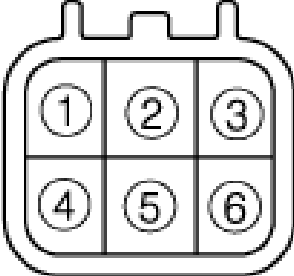
Low Voltage Connector - Resistance Value Checking		
Inspect CAN High/Low resistance between terminals ② and ⑤. <ul style="list-style-type: none"> ➤ OK → Approx. 120 Ω ➤ NG → Short (≒0 Ω) 		<ul style="list-style-type: none"> ① GND 12V ② CAN Low ③ Interlock (-) ④ IG 12V ⑤ CAN High ⑥ Interlock (+)
❖ Refer to Parts Information to verify Inverter Type.		
Inspect CAN Low ground resistance between terminals ① (DVOM + probe) and ② (DVOM - probe). Inspect CAN High ground resistance between terminals ① (DVOM + probe) and ⑤ (DVOM - probe). <ul style="list-style-type: none"> ➤ OK → 13~14 KΩ (Conventional Type) ➤ OK → 200~600 KΩ (High Performance DSP Type) ➤ NG → Short (≒0 Ω) (Both Inverter Types) 		
Inspect resistance at terminals ③ and ⑥ for interlock (-/+). <ul style="list-style-type: none"> ➤ OK → Below 1.0Ω ➤ NG → ∞MΩ 		

NOTE: Connect the high voltage connector in order to measure the interlock resistance.

5. Once it is determined that the Inverter of the Electric A/C Compressor needs replacement, refer to the applicable Shop Manual for the specific Removal and Installation procedure.

- Shop Manual > Heating, Ventilation and Air Conditioning > Air Conditioning System > Electric A/C Compressor > Repair procedures > Inverter

NOTE: If the inverter removal and installation service information is not available for a specific model, refer to the service information for a similar model until the information becomes available.

Parts Information:

- Part numbers may be subject to change. Newly created part numbers may be available.
- Refer to the latest Parts Catalog and filter by VIN for the applicable part numbers.

Model Year / Model	*Compressor Assembly	Compressor Body Kit	Compressor Inverter Kit	Compressor Inverter Type
19MY- (FE) NEXO FC	97701-M5000	97729-M5000	97728-M5000	High Performance DSP
15-17MY (LMFC) Tucson FC	97701-4W000	97229-4W000AS	97728-4W000	Conventional
19MY- (OS) KONA EV	97701-K4000	97729-K4000	97728-K4000	High Performance DSP
18MY- (AE) IONIQ PHEV	97701-G2800	97729-G2800	97728-G2800	Conventional
17MY- (AE) IONIQ HEV	97701-G2000	97729-G2000	97728-G2000	Conventional
17-19MY (AE) IONIQ EV	97701-G7000	97729-G7000	97728-G7000	Conventional
20MY- (AE) IONIQ EV	97701-G7200	97729-K4000		
16-19MY (LFE) Sonata PHEV	97701-E6100	97729-E6100	97728-E6100	Conventional
	97701-E6110	97729-E6110	97728-E6100	Conventional (~3/14/2019) High Performance DSP (3/15/2019-)
16-19MY (LFE) Sonata HEV	97701-E6000	97729-E6000	97728-E6000	Conventional (SOP~4/18/2019) High Performance DSP (4/19/2018-)
	97701-E6010	97729-E6010	97728-E6000	High Performance DSP (3/15/2019-)
11-15MY (YFE) Sonata HEV	97701-4U000	97229-4R000AS	97728-E7000	Conventional

NOTES:

- **Compressor body kit** contains the required bolt(s), gasket, and thermal paste.
 - Replace only if the motor or compressor portion is damaged/contaminated.
- **Compressor inverter kit** contains the required bolt(s), gasket, and thermal paste.
 - CAN High / CAN Low resistance specifications can differ depending on Inverter Type which can be determined by part number and VIN production date.
 - Replace the inverter whenever the pin testing results show an out of spec condition.
- **Electric compressor assembly** includes the compressor body and the compressor inverter.
 - *Availability of electric compressor assemblies will phase out after inventory depletion.

Warranty Information:

Model	OP Code	Operation	Op Time	Causal Part	Nature	Cause
Refer to Parts Information table for appropriate model	97731R00	Compressor Body Kit	Refer to WEB LTS for the current LTS time	Refer to Parts Information table above for applicable P/N	I11	N94
	97729R00	Compressor Inverter		I11	N66	
	09760A00	A/C Refrigerant Recovery & Charging		ACGAS00000	I12	N11

NOTE: Normal warranty procedures apply.