

IMPORTANT SAFETY RECALL

This notice applies to your vehicle. Your VIN(s) can be found on the bottom or back of this page.

Subject: Safety Recall: 20PBB – Model 520 Dual Steer Quick Release
NHTSA: 20V132
EXPIRATION DATE: NONE

Dear Peterbilt Customer,

You are receiving this notice in accordance with the National Traffic and Motor Vehicle Safety Act.

Peterbilt has decided that a defect, which relates to motor vehicle safety, may exist in certain Model 520 and 320 vehicles manufactured between 2/20/2015 and 7/16/2019. On certain trucks, a quick release valve may not have been installed. The absence of this valve could affect rear brake timing and could increase the risk of a crash or injury. Your vehicle has been identified as being built within the date range in which the quick release valve may not have been installed.

What is the problem?	A quick release valve that is required for proper brake timing may not have been installed.
What will your dealer do?	The brake plumbing will be inspected to see if the quick release valve was installed. If not, the valve will be installed.
What should you do?	Contact your Peterbilt Dealer to schedule an appointment for repair.

Peterbilt Motors Company has initiated this recall to remedy the issue with no charge to you. Please contact your Peterbilt dealer to schedule an appointment for these services. To find your Peterbilt dealer, please visit the Dealer Locator at www.Peterbilt.com or scan the QR code. When contacting your Peterbilt dealer, reference the Safety Recall number and the NHTSA number. This repair may take up to 1.0 hour of labor depending on dealer scheduling.

If you had this repair performed before receiving this letter, you may be eligible to receive reimbursement for the cost of obtaining a pre-notification remedy of the problem associated with this recall. Receipts for parts and/or labor are required for consideration of reimbursement. Contact your local Peterbilt dealership for details.

If you require further information about this recall, or experience any difficulty in making arrangements for this repair, please contact: Peterbilt Motors Company, 1700 Woodbrook St, Denton, TX 76205, Attn: Customer Services Department, phone 940-591-4220.

If you conclude that Peterbilt has not enabled you to remedy this defect in a reasonable time and without charge, you may submit a complaint to: Administrator, National Highway Traffic Safety Administration, 1200 New Jersey Avenue, S.E., Washington, DC 20590, or call the toll free Vehicle Safety Hotline at 1-888-327-4236 (TTY: 1-800-424-9153); or go to <http://www.safercar.gov>.

Federal regulation requires that any vehicle lessor receiving this recall notice must forward a copy of this notice to the lessee within ten days. If you no longer own this vehicle, we would appreciate your advising us of the new owner if you know their name.

We apologize for any inconvenience this preventive procedure may cause and thank you for your participation in helping Peterbilt provide the highest levels of customer satisfaction and service expertise. We value your business and appreciate your ongoing loyalty to Peterbilt and its dealer network. Industry-leading quality, performance and reliability are hallmarks of Peterbilt products, and we thank you for making Peterbilt your truck of choice.

Sincerely,

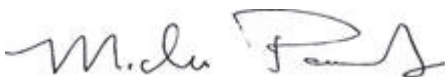

Michelle Ponsonby
Director of Customer Service
Peterbilt Motors Company

Scan this QR code to open the
Peterbilt Dealer Locator.





Federal Recall Information

20PBB

Supplier

Peterbilt

Description

Model 320/520 Dual Steer Quick Release

Release Date

3/24/2020

Introduction

Peterbilt has decided that certain Model 320 and 520 trucks built between 2/20/2015 and 7/16/2019 may have been built without a quick release valve. The absence of this valve could affect rear brake timing on certain vehicles equipped with a tri-drive or liftable tag axle and Dual Seated or Right Hand Stand-Up steering configurations.

Resolution

Safety Recall

Service all affected chassis that enter your dealership, even if the customer has no issue with the chassis.

1. Review the attached chassis list for your dealer code and schedule your customer(s) for service if their chassis is on the list.
 2. If you are not using Service Management to start repair orders, review SIR for "Complete" or "In Process" next to the "20PBB" campaign code prior to performing this repair.
 3. Follow the procedures below to inspect the brake plumbing and, if necessary, install the quick release valve.
-

It is a violation of Federal law for a dealer to sell or lease new vehicles covered by this recall until the defect or noncompliance has been corrected.

Warranty

There is no time or mileage limit for this recall. Peterbilt will pay for parts at dealer net plus applicable mark up and labor:

- 0.3 hours to inspect the brake plumbing to see if the quick release valve is installed. File Quick Claim 20PBBA.
 - This labor is for inspection only. It is not applicable for trucks that require the quick release valve installation.
- 0.4 hours to install the quick release valve and complete the necessary plumbing for Dual Seated Drive configuration. File Quick Claim 20PBBB. This includes the inspection of the brake plumbing for the presence of the

- 0.4 hours to install the quick release valve and complete the necessary plumbing for Right Hand Stand-Up configuration. File Quick Claim 20PBB. This includes the inspection of the brake plumbing for the presence of the quick release valve.
- File an additional claim for extraordinary circumstances, referencing 20PBB. A quick claim for standard labor must be filed first.

For Field...	Enter...
Failure Location	013-010-008
Failure Type	705
Claim Type	C
Campaign Number	20PBB
Labor	SRT 013-183 0.3 hours to inspect the brake plumbing for the quick release valve. SRT 013-184 0.4 hours to install and plumb the quick release valve – includes inspection for the presence of the valve.

Take-off parts disposition: Destroy parts 30 days after the claim has been paid.

Parts

Parts are available through PACCAR Parts.

DUAL SEATED DRIVE CONFIGURATION		
Quantity	Part Number	Description
1	288251BXW	Quick Release Valve
2	K041-809-30	Hex Bolt
2	27-00801-005	Flat Washer
1	G38-1021-0608	90 Degree Male Fitting
1	G38-1023-0608	Straight Male Fitting
1	AP2335	3/8 IN Plug
1 foot	Source Locally	#8 Orange or Black Nylon Brake Hose – 1 foot
As Needed	Source Locally	Teflon Tape
As Needed	Source Locally	Cable Ties

RH STAND-UP CONFIGURATION		
Quantity	Part Number	Description
1	288251BXW	Quick Release Valve
2	K041-809-30	Hex Bolt
2	27-00801-005	Flat Washer
2	G38-1023-0608	Straight Male Fitting

1	AP2335	3/8 IN Plug
1 foot	Source Locally	#8 Orange or Black Nylon Brake Hose – 1 foot
As Needed	Source Locally	Teflon Tape
As Needed	Source Locally	Cable Ties

Procedure

1. Inspect the truck to see if the Quick Release (QR) valve is installed. If not installed as shown below, tilt the cab forward for access and bolt the QR valve to the washer bottle housing.

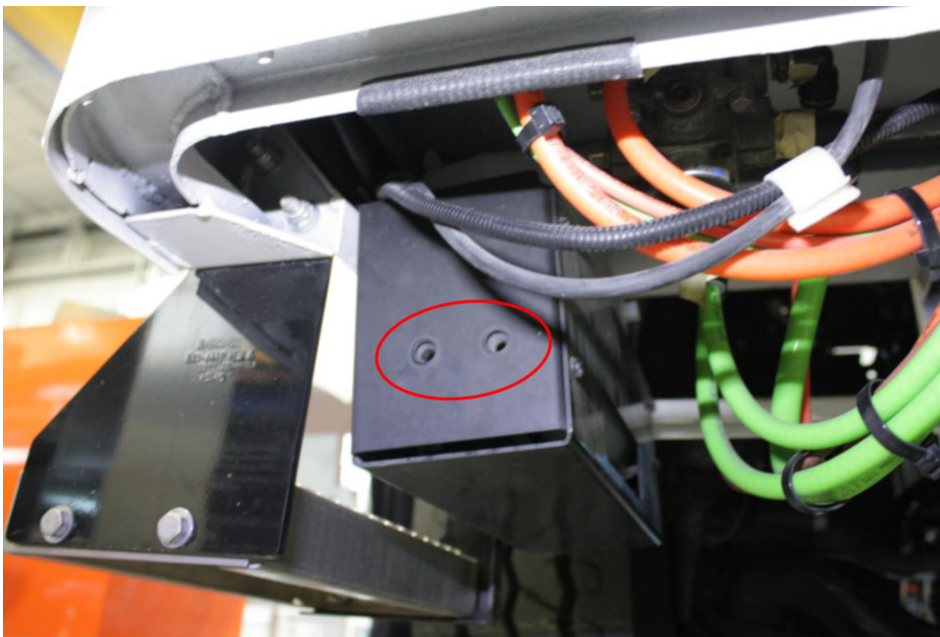

2. Using the images below, determine the correct plumbing for the QR valve and locate the primary delivery hose from the foot valve that will be routed to the QR valve.
3. Wrap the threads of the fittings with Teflon tape and install into the QR valve as shown for the appropriate steering configuration below.
4. Remove the primary delivery hose from the foot valve, trim the excess if necessary and install in the outlet port of the QR valve.
5. Cut a new section of hose to install from the QR valve inlet back to the foot valve.

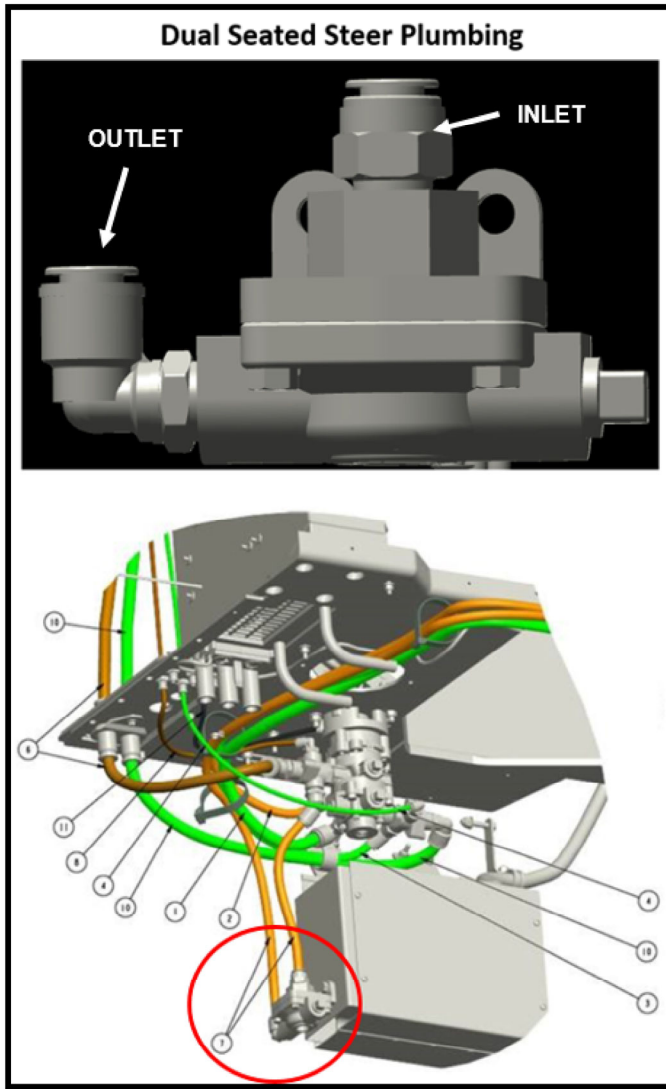

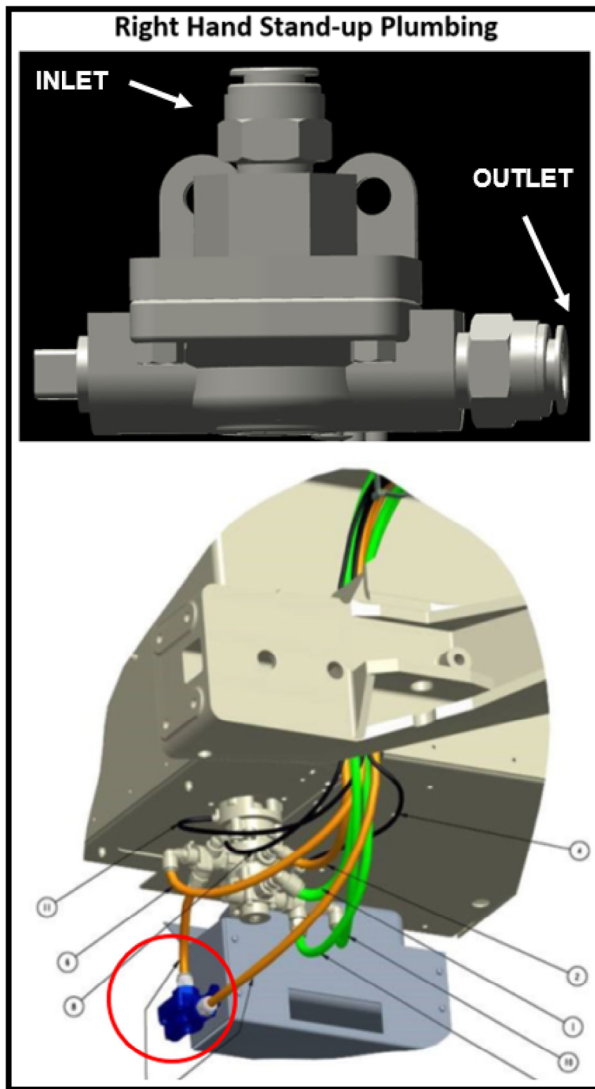

6. Avoid kinking the hoses and secure the hose bundle with cable ties.

Attachments

[Chassis List](#)
[Customer Letter – US](#)
[Customer Letter – Canada](#)
[Customer Letter – Canada \(French\)](#)

Authored by: PR

Access to PACCAR's Enterprise Portal is provided as a benefit of doing business with PACCAR. All applications and content accessed through this system are confidential and proprietary and the property of PACCAR Inc and its suppliers, and must be kept strictly confidential pursuant to the contract licensing such access. Disclosure, publication, release or distribution of any material found on PACCAR systems to any person other than employees with a need to know such information is strictly prohibited. All activity on this system is monitored. If PACCAR suspects or discovers any unauthorized activity, access may be immediately terminated without prior notification. Violators may be subject to legal action.

© Copyright 2020 PACCAR Inc. All rights reserved. We welcome your [feedback](#) on this page. For technical questions or concerns about this page, please contact the [DealerNet Webmaster](#).