

# Technical Service Bulletin

Mazda North American Operations  
Irvine, CA 92618-2922



<b>Subject:</b>  <b>CLICK OR SQUEAK NOISE FROM FRONT BRAKES</b>	<b>Bulletin No.:</b> 04-004/20
	<b>Last Issued:</b> 03/19/2020

## BULLETIN NOTES

This bulletin supersedes the previously issued bulletin(s) listed below. The changes are noted in Red text.

Previous TSBs:	Date(s) Issued:
04-004/20	02/20/20 and 03/06/20
04-006/18	07/30/18

## APPLICABLE MODEL(S)/VINS

2016-2020 CX-9

## DESCRIPTION

Some vehicles may exhibit a click or squeak noise from the front brakes under the following conditions:

Page 1 of 16

**CONSUMER NOTICE:** The information and instructions in this bulletin are intended for use by skilled technicians. Mazda technicians utilize the proper tools/equipment and take training to correctly and safely maintain Mazda vehicles. These instructions should not be performed by "do-it-yourselfers." Customers should not assume this bulletin applies to their vehicle or that their vehicle will develop the described concern. To determine if the information applies, customers should contact their nearest authorized Mazda dealership. Mazda North American Operations reserves the right to alter the specifications and contents of this bulletin without obligation or advance notice. All rights reserved. No part of this bulletin may be reproduced in any form or by any means, electronic or mechanical---including photocopying and recording and the use of any kind of information storage and retrieval system ---without permission in writing.

Affected Model Years	Noise	Condition	Cause / Mass-Production Change
2016-2020 CX-9	Click	1. When first moving forward or reverse from a stop.  OR  2. When first applying the brakes while moving forward at slow speeds.	Cause: Due to deteriorated grease between the brake pads and the shim, the front brake pads move upward/downward along with the brake rotors during brake application. When the vehicle moves or the brakes are applied the next time, the front brake pads move to the other side, which causes a click noise.  Mass-Production Change: None
2016-2018 CX-9 vehicles with VINs lower than JM3TC*****231530 (produced before Apr. 27, 2018)	Squeak	During light braking	Cause: Occurs when the front brake pads have been worn to certain levels. As the pads wear, the chamfer goes away and the grease between the pad and the shim deteriorates.  Mass-Production Change: As of Apr. 27, 2018, the chamfer shape of the brake pad was improved to increase durability.

Customers having this concern should have their vehicle repaired using the following repair procedure.

**CONSUMER NOTICE:** The information and instructions in this bulletin are intended for use by skilled technicians. Mazda technicians utilize the proper tools/equipment and take training to correctly and safely maintain Mazda vehicles. These instructions should not be performed by "do-it-yourselfers." Customers should not assume this bulletin applies to their vehicle or that their vehicle will develop the described concern. To determine if the information applies, customers should contact their nearest authorized Mazda dealership. Mazda North American Operations reserves the right to alter the specifications and contents of this bulletin without obligation or advance notice. All rights reserved. No part of this bulletin may be reproduced in any form or by any means, electronic or mechanical---including photocopying and recording and the use of any kind of information storage and retrieval system ---without permission in writing.

**REPAIR PROCEDURE**

1. Verify the customer concern.

- If the vehicle emits a click noise during light braking, proceed to **REPAIR A: 2016-2020 CX-9 - CLICK NOISE FROM FRONT BRAKES**

- If the vehicle emits a squeak noise during light braking, proceed to **REPAIR B: 2016-2018 CX-9 - FRONT BRAKE SQUEAK DURING LIGHT BRAKING**

**NOTE:** Repair B only applies to 2016-2018 CX-9 vehicles with VINs lower than JM3TC\*\*\*\*\*231530 (produced before Apr. 27, 2018).

**REPAIR A: 2016-2020 CX-9 - CLICK NOISE FROM FRONT BRAKES**

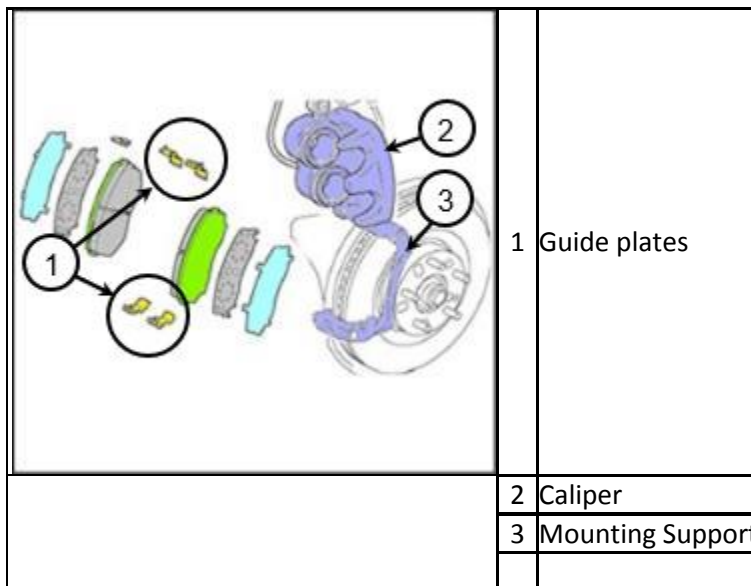

**NOTE:** This repair includes attaching the protectors to the original guide plates (1), then apply white grease to the specified locations as outlined below.

1. Remove the front brake pads (both sides) according to MGSS online (DISC PAD (FRONT) REPLACEMENT).

**CONSUMER NOTICE:** The information and instructions in this bulletin are intended for use by skilled technicians. Mazda technicians utilize the proper tools/equipment and take training to correctly and safely maintain Mazda vehicles. These instructions should not be performed by "do-it-yourselfers." Customers should not assume this bulletin applies to their vehicle or that their vehicle will develop the described concern. To determine if the information applies, customers should contact their nearest authorized Mazda dealership. Mazda North American Operations reserves the right to alter the specifications and contents of this bulletin without obligation or advance notice. All rights reserved. No part of this bulletin may be reproduced in any form or by any means, electronic or mechanical---including photocopying and recording and the use of any kind of information storage and retrieval system ---without permission in writing.

2. Clean the guide plates (1) and the guide plate seating area of the mounting support (2) using brake cleaner or equivalent.

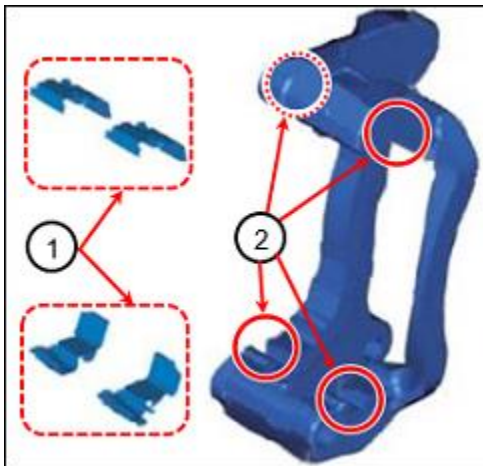
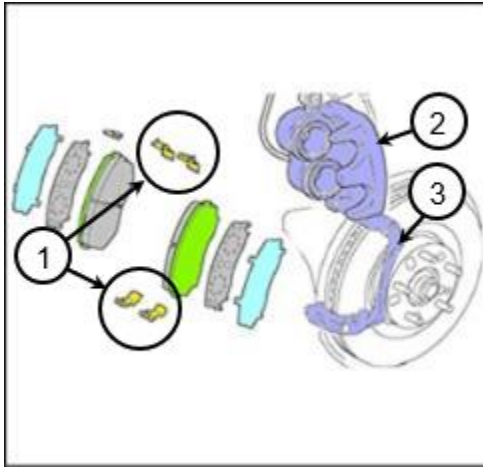

3. Attach protector (4) to the removed guide plates (3) (as shown below).

4. Reinstall the guide plate (3) to the mounting support (2).

**CONSUMER NOTICE:** The information and instructions in this bulletin are intended for use by skilled technicians. Mazda technicians utilize the proper tools/equipment and take training to correctly and safely maintain Mazda vehicles. These instructions should not be performed by "do-it-yourselfers." Customers should not assume this bulletin applies to their vehicle or that their vehicle will develop the described concern. To determine if the information applies, customers should contact their nearest authorized Mazda dealership. Mazda North American Operations reserves the right to alter the specifications and contents of this bulletin without obligation or advance notice. All rights reserved. No part of this bulletin may be reproduced in any form or by any means, electronic or mechanical---including photocopying and recording and the use of any kind of information storage and retrieval system ---without permission in writing.

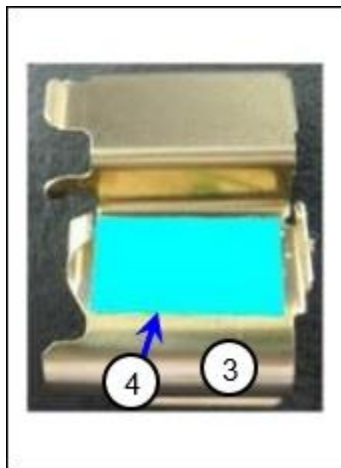
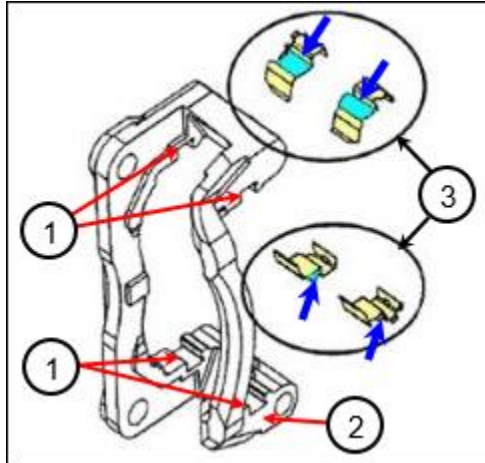

**NOTE:** When the protector (4) is properly attached, there should be no clearance between the guide plate and mounting support.

5. Clean the end (1) of the pistons (pad-to-shim contact surface) and the caliper clips (2) (shim contact area) using brake cleaner or equivalent. Also, wipe off old grease from the pad-to-shim contact surface, including molded holes and from the inner/outer shims (all shims).

**CONSUMER NOTICE:** The information and instructions in this bulletin are intended for use by skilled technicians. Mazda technicians utilize the proper tools/equipment and take training to correctly and safely maintain Mazda vehicles. These instructions should not be performed by "do-it-yourselfers." Customers should not assume this bulletin applies to their vehicle or that their vehicle will develop the described concern. To determine if the information applies, customers should contact their nearest authorized Mazda dealership. Mazda North American Operations reserves the right to alter the specifications and contents of this bulletin without obligation or advance notice. All rights reserved. No part of this bulletin may be reproduced in any form or by any means, electronic or mechanical---including photocopying and recording and the use of any kind of information storage and retrieval system ---without permission in writing.

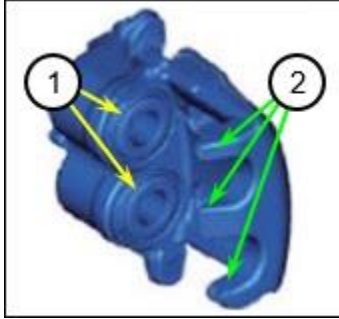

6. Push the pistons into the caliper using a commercially available disc brake expanding tool.

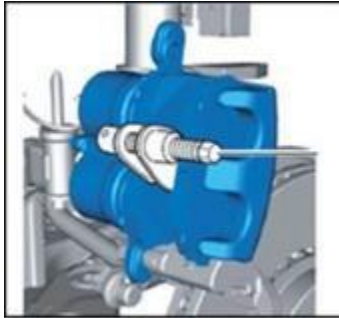

7. Verify that the dust seal installation position is lower than the piston surface (as shown below).

**CONSUMER NOTICE:** The information and instructions in this bulletin are intended for use by skilled technicians. Mazda technicians utilize the proper tools/equipment and take training to correctly and safely maintain Mazda vehicles. These instructions should not be performed by "do-it-yourselfers." Customers should not assume this bulletin applies to their vehicle or that their vehicle will develop the described concern. To determine if the information applies, customers should contact their nearest authorized Mazda dealership. Mazda North American Operations reserves the right to alter the specifications and contents of this bulletin without obligation or advance notice. All rights reserved. No part of this bulletin may be reproduced in any form or by any means, electronic or mechanical---including photocopying and recording and the use of any kind of information storage and retrieval system ---without permission in writing.

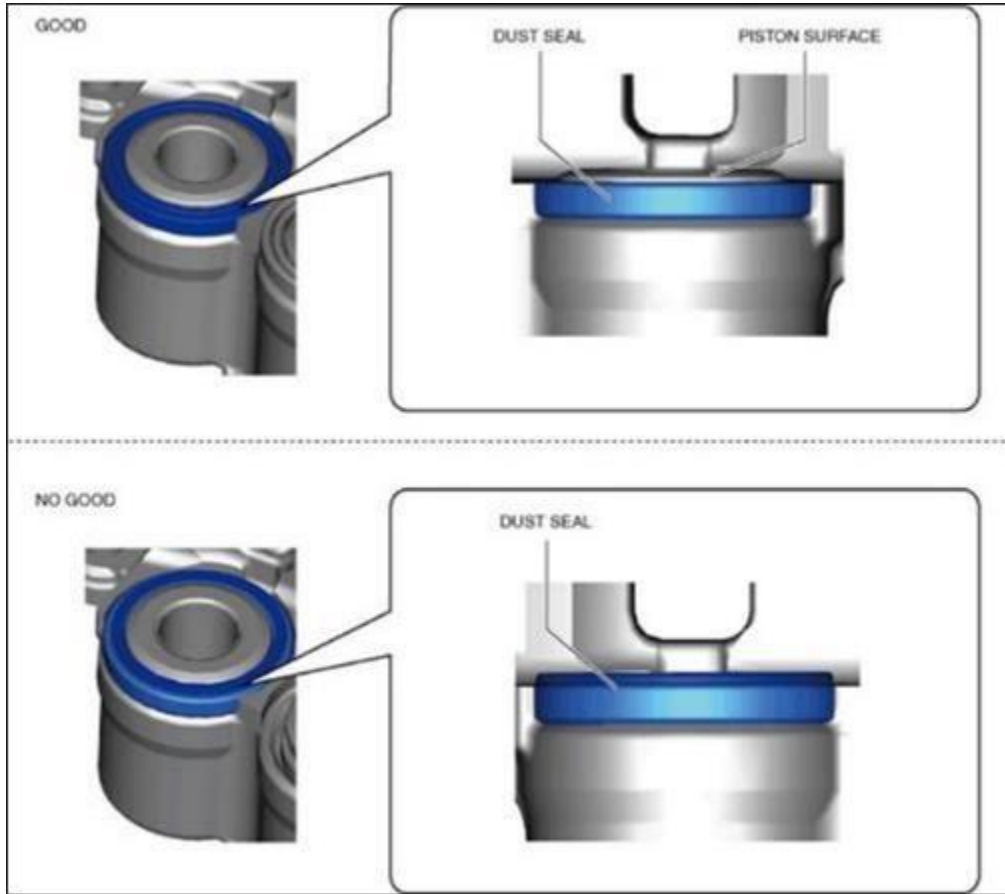

- If the dust seal protrudes from the piston surface, install the SST (as shown below) and press the dust seal back to the correct position.



**CONSUMER NOTICE:** The information and instructions in this bulletin are intended for use by skilled technicians. Mazda technicians utilize the proper tools/equipment and take training to correctly and safely maintain Mazda vehicles. These instructions should not be performed by "do-it-yourselfers." Customers should not assume this bulletin applies to their vehicle or that their vehicle will develop the described concern. To determine if the information applies, customers should contact their nearest authorized Mazda dealership. Mazda North American Operations reserves the right to alter the specifications and contents of this bulletin without obligation or advance notice. All rights reserved. No part of this bulletin may be reproduced in any form or by any means, electronic or mechanical---including photocopying and recording and the use of any kind of information storage and retrieval system ---without permission in writing.

8. Lightly and evenly apply white grease to the end of the pistons (as shown below).

**NOTE:**

- Use one (1) package of grease (5g) per side.
- Do not allow the grease to stick to the friction surfaces of the brake pads and discs.
- Do not allow the grease to stick to the piston boot rubber areas.

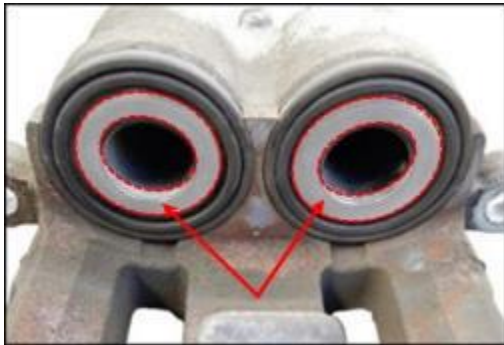

9. Lightly and evenly apply white grease to the caliper clips (shim contact area) as shown below.

**NOTE:** During caliper installation, make sure the grease applied to the parts is not scraped off.



**CONSUMER NOTICE:** The information and instructions in this bulletin are intended for use by skilled technicians. Mazda technicians utilize the proper tools/equipment and take training to correctly and safely maintain Mazda vehicles. These instructions should not be performed by "do-it-yourselfers." Customers should not assume this bulletin applies to their vehicle or that their vehicle will develop the described concern. To determine if the information applies, customers should contact their nearest authorized Mazda dealership. Mazda North American Operations reserves the right to alter the specifications and contents of this bulletin without obligation or advance notice. All rights reserved. No part of this bulletin may be reproduced in any form or by any means, electronic or mechanical---including photocopying and recording and the use of any kind of information storage and retrieval system ---without permission in writing.



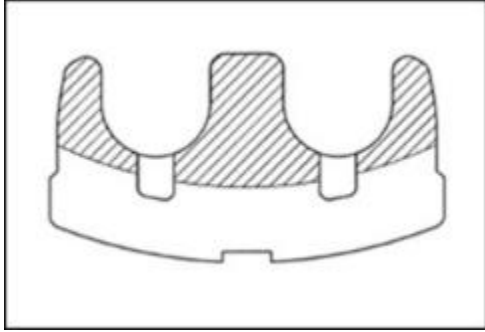

**CAUTION:DO NOT** allow the grease to stick to the guide plate seating areas and guide plates (as shown below).



10. Lightly and evenly apply the remaining white grease between the cleaned pad and the shim.

a) Evenly apply 1/4 of the white grease over the back of the pad, then install the rubber coated shim.

**NOTE:** In case of a multi-layer shim, apply half of the white grease over the back of the pad, then install the

**CONSUMER NOTICE:** The information and instructions in this bulletin are intended for use by skilled technicians. Mazda technicians utilize the proper tools/equipment and take training to correctly and safely maintain Mazda vehicles. These instructions should not be performed by "do-it-yourselfers." Customers should not assume this bulletin applies to their vehicle or that their vehicle will develop the described concern. To determine if the information applies, customers should contact their nearest authorized Mazda dealership. Mazda North American Operations reserves the right to alter the specifications and contents of this bulletin without obligation or advance notice. All rights reserved. No part of this bulletin may be reproduced in any form or by any means, electronic or mechanical---including photocopying and recording and the use of any kind of information storage and retrieval system ---without permission in writing.

multi-layer shim.



b) Evenly apply 1/4 of the white grease over the rubber coated shim then install the outer shim.



c) Apply remaining half of the white grease to the other combination of pad and shim.

d) Apply the other package of the white grease to the other side of the vehicle.

11. Install the pads and shims and other parts according to MGSS online (DISC PAD (FRONT) REPLACEMENT).

12. After completing the installation, depress the brake pedal a few times and confirm that the brake pedal does not feel spongy.

13. Verify the repair.

**CONSUMER NOTICE:** The information and instructions in this bulletin are intended for use by skilled technicians. Mazda technicians utilize the proper tools/equipment and take training to correctly and safely maintain Mazda vehicles. These instructions should not be performed by "do-it-yourselfers." Customers should not assume this bulletin applies to their vehicle or that their vehicle will develop the described concern. To determine if the information applies, customers should contact their nearest authorized Mazda dealership. Mazda North American Operations reserves the right to alter the specifications and contents of this bulletin without obligation or advance notice. All rights reserved. No part of this bulletin may be reproduced in any form or by any means, electronic or mechanical---including photocopying and recording and the use of any kind of information storage and retrieval system ---without permission in writing.

**REPAIR B: 2016-2018 CX-9 - FRONT BRAKE SQUEAK DURING LIGHT BRAKING**

**NOTE:** Repair B only applies to 2016-2018 CX-9 vehicles with VINs lower than JM3TC\*\*\*\*\*231530 (produced before Apr. 27, 2018).

1. Remove the front brake pads according to the instructions on MGSS online DISC PAD (FRONT) REPLACEMENT.

**NOTE:** The modified pads alone are effective for brake squeak, but the modified shims and grease should also be used, especially for customers who are very sensitive to brake noise.

2. Clean the mounting support areas (1) with brake cleaner.

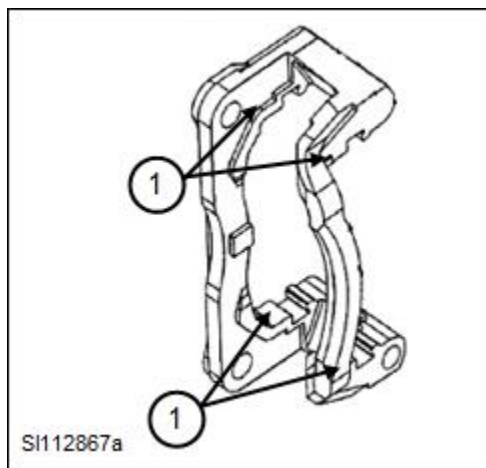

3. Clean the exposed area of the piston and the caliper pins with brake cleaner.

4. Press the piston in using a commercially available disc brake expander tool.

**CAUTION:** Do not use a pair of pliers etc. since the piston is made of plastic and may be damaged by pliers, etc.

5. Evenly apply the white grease between the pad and shim (as shown below).

**NOTE:**

- Use a half packet of white grease for the pad and shim (one (1) packet for one (1) side of the vehicle).
- Do not apply the white grease to the pad surface or disc plate.
- Wipe off any excess grease coming out of the applicable areas.
- Do not mix white grease with black grease.

**CONSUMER NOTICE:** The information and instructions in this bulletin are intended for use by skilled technicians. Mazda technicians utilize the proper tools/equipment and take training to correctly and safely maintain Mazda vehicles. These instructions should not be performed by "do-it-yourselfers." Customers should not assume this bulletin applies to their vehicle or that their vehicle will develop the described concern. To determine if the information applies, customers should contact their nearest authorized Mazda dealership. Mazda North American Operations reserves the right to alter the specifications and contents of this bulletin without obligation or advance notice. All rights reserved. No part of this bulletin may be reproduced in any form or by any means, electronic or mechanical---including photocopying and recording and the use of any kind of information storage and retrieval system ---without permission in writing.



SI112867b



SI112867c



SI112867d

**CONSUMER NOTICE:** The information and instructions in this bulletin are intended for use by skilled technicians. Mazda technicians utilize the proper tools/equipment and take training to correctly and safely maintain Mazda vehicles. These instructions should not be performed by "do-it-yourselfers." Customers should not assume this bulletin applies to their vehicle or that their vehicle will develop the described concern. To determine if the information applies, customers should contact their nearest authorized Mazda dealership. Mazda North American Operations reserves the right to alter the specifications and contents of this bulletin without obligation or advance notice. All rights reserved. No part of this bulletin may be reproduced in any form or by any means, electronic or mechanical---including photocopying and recording and the use of any kind of information storage and retrieval system ---without permission in writing.

6. Attach the shim as shown.



7. Remove the shim and confirm the grease has been applied evenly (as shown below).



8. Install the front brake pads according to the instructions on MGSS online DISC PAD (FRONT) REPLACEMENT.

**NOTE:** Replace the guide plates (1) with the new ones included in the shim set.

**CONSUMER NOTICE:** The information and instructions in this bulletin are intended for use by skilled technicians. Mazda technicians utilize the proper tools/equipment and take training to correctly and safely maintain Mazda vehicles. These instructions should not be performed by "do-it-yourselfers." Customers should not assume this bulletin applies to their vehicle or that their vehicle will develop the described concern. To determine if the information applies, customers should contact their nearest authorized Mazda dealership. Mazda North American Operations reserves the right to alter the specifications and contents of this bulletin without obligation or advance notice. All rights reserved. No part of this bulletin may be reproduced in any form or by any means, electronic or mechanical---including photocopying and recording and the use of any kind of information storage and retrieval system ---without permission in writing.

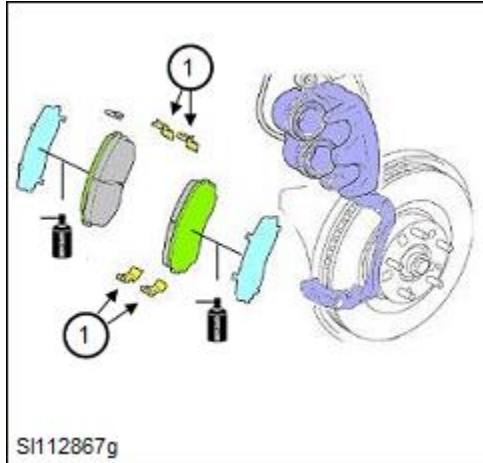

9. After installation, depress the brake pedal a few times and confirm that the brake pedal does not feel spongy.

10. Verify the repair.

**CONSUMER NOTICE:** The information and instructions in this bulletin are intended for use by skilled technicians. Mazda technicians utilize the proper tools/equipment and take training to correctly and safely maintain Mazda vehicles. These instructions should not be performed by "do-it-yourselfers." Customers should not assume this bulletin applies to their vehicle or that their vehicle will develop the described concern. To determine if the information applies, customers should contact their nearest authorized Mazda dealership. Mazda North American Operations reserves the right to alter the specifications and contents of this bulletin without obligation or advance notice. All rights reserved. No part of this bulletin may be reproduced in any form or by any means, electronic or mechanical---including photocopying and recording and the use of any kind of information storage and retrieval system ---without permission in writing.

**PARTS INFORMATION****REPAIR A: 2016-2020 CX-9 - CLICK NOISE FROM FRONT BRAKES**

Parts Number	Description	Qty.	Notes
L2Y7-33-247	Grease	1	2 x (5g each)
L2Y7-43-782	Protector	1	25 pcs. (8 needed per vehicle)

**REPAIR B: FRONT BRAKE SQUEAK DURING LIGHT BRAKING**

**Applicable: 2016-2018 CX-9 vehicles with VINs lower than JM3TC\*\*\*\*\*231530 (produced before Apr. 27, 2018)**

Parts Number	Description	Qty.	Notes
TNY9-33-28Z	Pad Set	1	Includes one (1) package of grease
KCYR-33-29Z	Shim Set	1	Includes one (1) package of grease

**CONSUMER NOTICE:** The information and instructions in this bulletin are intended for use by skilled technicians. Mazda technicians utilize the proper tools/equipment and take training to correctly and safely maintain Mazda vehicles. These instructions should not be performed by "do-it-yourselfers." Customers should not assume this bulletin applies to their vehicle or that their vehicle will develop the described concern. To determine if the information applies, customers should contact their nearest authorized Mazda dealership. Mazda North American Operations reserves the right to alter the specifications and contents of this bulletin without obligation or advance notice. All rights reserved. No part of this bulletin may be reproduced in any form or by any means, electronic or mechanical---including photocopying and recording and the use of any kind of information storage and retrieval system ---without permission in writing.

**WARRANTY INFORMATION****NOTE:**

- This warranty information applies only to verified customer complaints on vehicles eligible for warranty repair.
  - This repair will be covered under Mazda's New Vehicle Limited Warranty term.
  - Additional diagnostic time cannot be claimed for this repair.

<b>REPAIR A: 2016-2020 CX-9 - CLICK NOISE FROM FRONT BRAKES</b>	
Warranty Type	A
Symptom Code	35
Damage Code	9E
Part Number Main Cause	L2Y6-33-29Z
Quantity	0
Operation Number / Labor Hours:	XXRC3XRX / 0.6 Hrs.

**NOTE:**

- Claim Grease (L2Y7-33-247) and Protector (L2Y7-43-782) as related parts.
- Claim Protector as a related part for the first time repair.

<b>REPAIR B: FRONT BRAKE SQUEAK DURING LIGHT BRAKING</b>	
<b>NOTE: Repair B only applies to 2016-2018 CX-9 vehicles with VINs lower than JM3TC*****231530 (produced before Apr. 27, 2018).</b>	
Warranty Type	A
Symptom Code	35
Damage Code	99
Part Number Main Cause	TNY9-33-28Z
Quantity	0
Operation Number / Labor Hours:	XXP6EXRX / 0.4 Hrs.

**CONSUMER NOTICE:** The information and instructions in this bulletin are intended for use by skilled technicians. Mazda technicians utilize the proper tools/equipment and take training to correctly and safely maintain Mazda vehicles. These instructions should not be performed by "do-it-yourselfers." Customers should not assume this bulletin applies to their vehicle or that their vehicle will develop the described concern. To determine if the information applies, customers should contact their nearest authorized Mazda dealership. Mazda North American Operations reserves the right to alter the specifications and contents of this bulletin without obligation or advance notice. All rights reserved. No part of this bulletin may be reproduced in any form or by any means, electronic or mechanical---including photocopying and recording and the use of any kind of information storage and retrieval system ---without permission in writing.