

Sports Exhaust System - Silver (OP8)/Black (OP9)

Vehicle type: **911 Carrera (992)/911 Carrera S (992)/911 Carrera 4 (992)/911 Carrera 4S (992)**

Model Year: **As of 2020**

Engine Types: Carrera S/4S: **DKK/DKKA** = 6-cylinder/3.0 liter/331 kW (450 hp)
 Carrera/Carrera 4: **DKC/DKCA** = 6-cylinder/3.0 liter/283 kW (385 hp)

Restrictions: **ONLY** approved for vehicles produced from 39/2018 (week/year)!

Information: **Retrofitting**

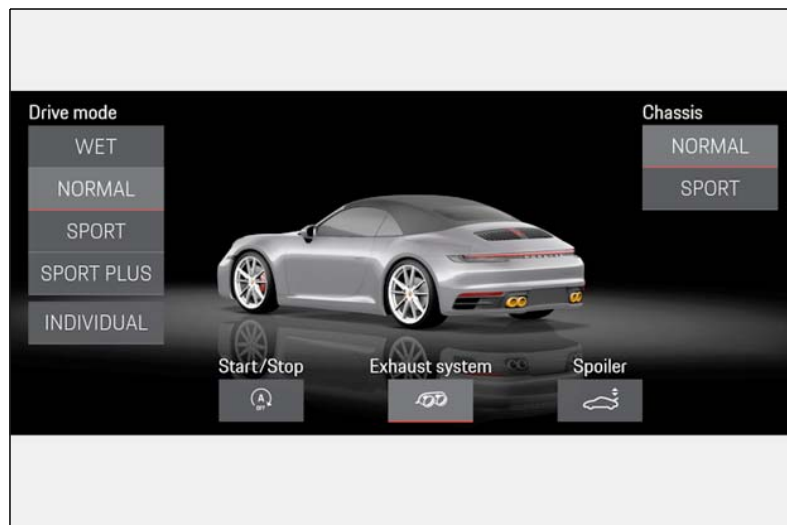

Figure 1

Notes: In the sports exhaust system, the signal for activating the flaps in the silencer comes from the respective current map in the DME control unit. This depends on the driving status and accelerator pedal position among other things.

Engine power and exhaust behaviour of the vehicle are not affected.

The sports exhaust system is also available straight from the factory for new vehicles by requesting optional equipment "OP8 – Sports exhaust system (Brushed stainless steel tailpipe)" or "OP9 – Sports exhaust system (Black chrome-plated look tailpipe)".

Switching the sports exhaust system on and off:

- Porsche Communication Management (⇒ Figure 1): Select the menu "Car" → "Drive" → "Exhaust system"

- Porsche Communication Management (⇒ *Figure 1*): Select "SPORT" or "SPORT PLUS"
- Quick-access button in the keypad (below PCM, see also "911 – Good to know" – "Practical Tips" and "Strip for switches")
- Quick-access button on the multi-function steering wheel (if available, see also "911 – Good to know" – "Practical Tips" and "Instrument cluster")

Parts Info:	992.044.210	⇒ Sports exhaust system – Tailpipe in Silver chrome-plated look, set
	992.044.212	⇒ Sports exhaust system – Tailpipe in Black chrome-plated look, set

Also order the following parts in accordance with vehicle equipment:

Vehicles **WITHOUT** SportDesign package (– 2D1):

992.807.833.A.OK1	1 x	⇒ Exhaust pipe cover, left, Matt Black
992.807.834.A.OK1	1 x	⇒ Exhaust pipe cover, right, Matt Black
992.807.983.C.OK1¹	1 x	⇒ Cover, lower rear, Matt Black– USA/Canada

¹ Check country version!

Vehicles **WITH** SportDesign package (+ 2D1):

992.807.833.C.OK1	1 x	⇒ Exhaust pipe cover, left, Matt Black
992.807.834.C.OK1	1 x	⇒ Exhaust pipe cover, right, Matt Black
992.807.983.F.OK1	1 x	⇒ Cover, lower rear, Matt Black



Information

Before ordering the additional parts:

Check vehicle equipment and country versions in the Porsche Electronic Parts (PET) catalog!

Parts list:

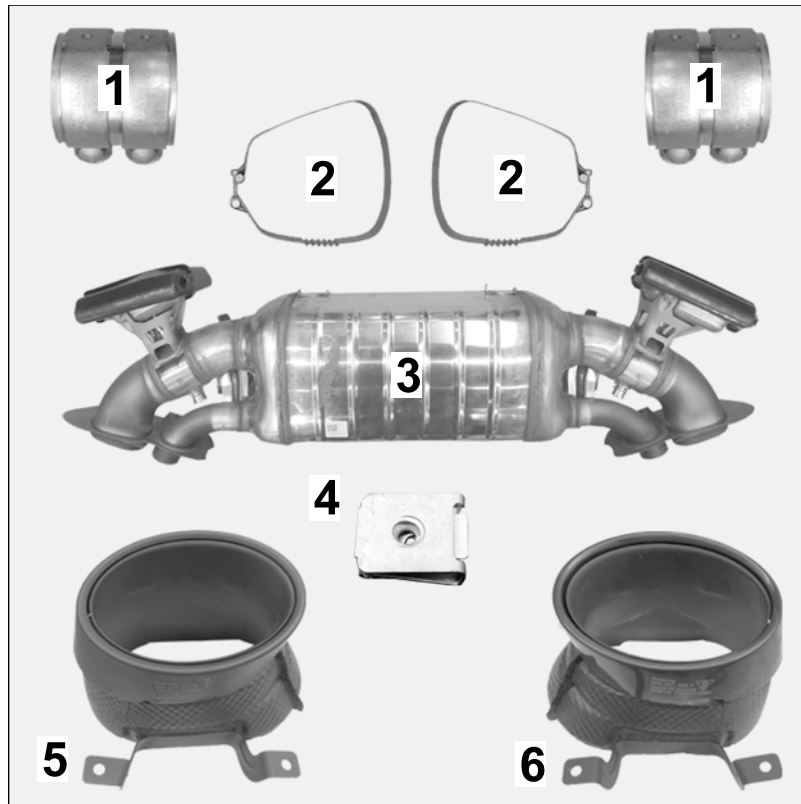

Figure 2

992.253.143.A	2 x	Clamping sleeve, Ø 70 x 75 ⇒ Figure 2-1-
992.251.571	2 x	Restraining strap ⇒ Figure 2-2-
992.251.053.A	1 x	Silencer assembly for sports exhaust system ⇒ Figure 2-3-
N.912.425.01	6 x	Speed nut, St 4.8 x 22 x 18 (exhaust pipe cover) ⇒ Figure 2-4-
992.251.187.P ²	1 x	Sports tailpipe, Black chrome-plated, left ⇒ Figure 2-5-
992.251.188.P ²	1 x	Sports tailpipe, Black chrome-plated, right ⇒ Figure 2-6-
992.251.187.N ²	1 x	Sports tailpipe, Silver chrome-plated, left (not shown)
992.251.188.N ²	1 x	Sports tailpipe, Silver chrome-plated, right (not shown)
PAF.912.769	6 x	Screw, 4.8 x 16 (not shown)

2 **ONLY** contained in respective set!

Notes:

The relevant legal regulations must be observed in the various countries.

- e13*2007/46*0992*00 = 911 Carrera S/911 Carrera 4S
- e13*2007/46*0992*04 = 911 Carrera
- e13*2007/46*0992*05 = 911 Carrera 4

The underside (\Rightarrow *Figure 3*) of the new sports exhaust system (silencers and sports tailpipes) is marked as follows:

- 1 – Porsche logo
- 2 – Porsche part no.
- 3 – Week (W) and year of manufacture
- 4 – Type number

- Silencer: Porsche Part No. = 992.251.053.A / Type number = 992 120 B
- Sports tailpipes: Porsche Part Nos. = see Parts list

This information can be read off from underneath when installed.



Information

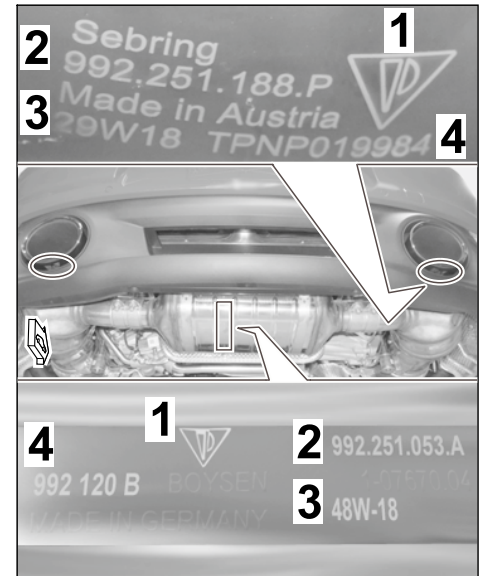

Figure 3

Tools:

9900 - PIWIS Tester 3
Torque wrench, 2-10 Nm (1.5-7.5 ftlb.)
 Restraining strap for securing loads

Transmission and Engine Jack
Torque wrench, 40-200 Nm (30-148 ftlb.)
 Shop light

Work Procedure: 1 Preparatory work

- 1.1 Drive vehicle onto a lifting platform (\Rightarrow *Workshop Manual '4X00IN Lifting the vehicle'*).
- 1.2 Connect battery charger (\Rightarrow *Workshop Manual '2X00IN Trickle charging 12-volt lithium-ion battery'*).
- 1.3 Remove wheels on rear axle (\Rightarrow *Workshop Manual '440519 Removing and installing wheel'*).
- 1.4 Remove rear apron (\Rightarrow *Workshop Manual '635519 Removing and installing rear apron'*).
 - 1 – Air guide for charge-air cooling
 - 2 – Bumper bracket with foam section
- 1.5 Remove rear bumper (\Rightarrow *Workshop Manual '635019 Removing and installing rear bumper'*, \Rightarrow *Figure 4*)

2 Replace muffler

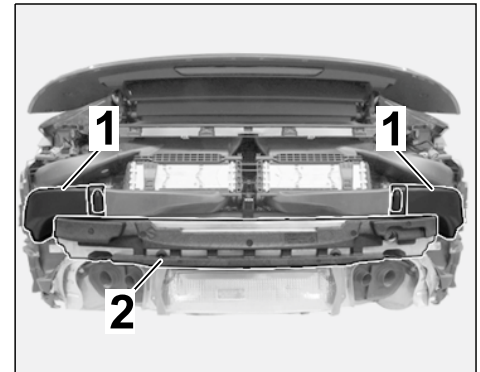

Figure 4

⚠ CAUTION**Hot components**

- Risk of burns
- ⇒ Let hot components cool down.
- ⇒ Wear personal protective gear.

⚠ CAUTION**Heavy components**

- Risk of pinching
- ⇒ Wear personal protective gear.
- ⇒ Get someone to help if necessary.

- 2.1 **Transmission and Engine Jack** must be positioned under the exhaust system (in transfer case area). Then, secure the exhaust system with restraining straps to prevent it from falling down.
- 2.2 Disconnect electric plug connection for exhaust flap (left/right) on the muffler.

**Information**

The help of another person is required for this step.

- 2.3 Remove muffler (⇒ *Workshop Manual '263319 Removing and installing rear silencer'*)
- 2.4 Install new muffler for sport exhaust system (⇒ *Workshop Manual '263319 Removing and installing rear silencer'*)

- 2.4.1 Engage new restraining strap (2 ea.) with screw heads facing downwards on the muffler holder (⇒ *Figure 5*).

- 1 – New restraining strap (2 x)
- 2 – Muffler holder

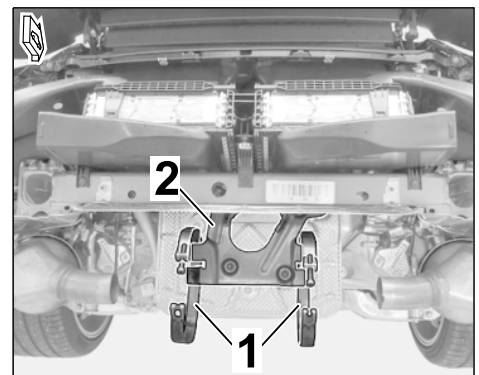

Figure 5

2.4.2 Remove transport protection shell on the new muffler in the exhaust flap connector area (⇒ *Figure 6*).

- 1 – Transport protection shell
- 2 – Exhaust pipe on muffler (right)

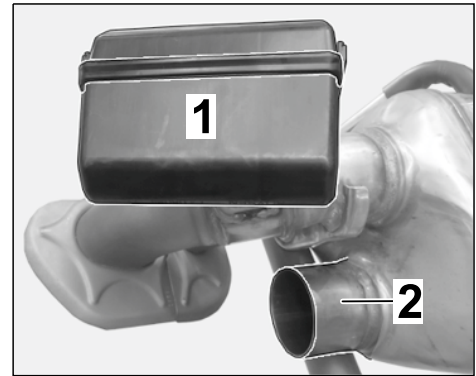

Figure 6

2.4.3 Coat exhaust pipe on catalytic converter (at the left/right) and on the new muffler (at the left/right) with high-temperature grease.

2.4.4 Install new clamping sleeve (Ø 70 x 75, 2 ea.) on exhaust pipe on catalytic converter (at the left/right).



Information

The help of another person is required for this step.

2.4.5 Position new muffler for sport exhaust system on the muffler holder and pre-install hand-tight with new restraining straps (2 ea.) (⇒ *Figure 7*).

- 1 – Muffler for sport exhaust system
- 2 – Clamping sleeve, Ø 70 x 75
- 3 – Restraining strap
- 4 – Protective plate

2.4.6 Check whether the protective plate is touching the catalytic converter (⇒ *Figure 7-insets*-).

- If it is (⇒ *Figure 7-A*-): Correct the position of the muffler or bend the cover away if necessary so that there is a gap of at least 3–5 mm (⇒ *Figure 7-B*-) between the plate and catalytic converter!
- If not (⇒ *Figure 7-B*-): Continue with the next step.

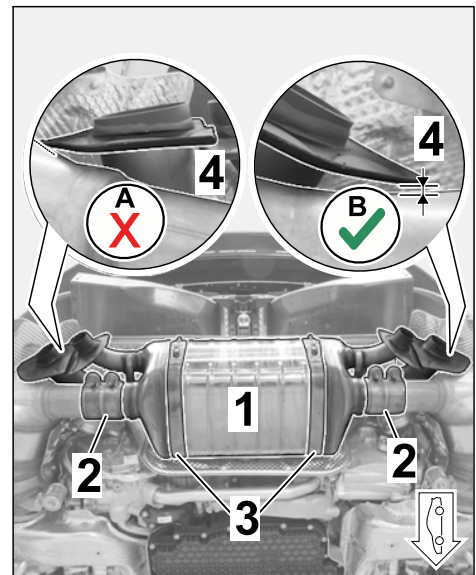

Figure 7

2.4.7 Move new clamping sleeve (Ø 70 x 75, 2 ea. ⇒ *Figure 7-2*-) as far as the markings on the exhaust pipe on the catalytic converter/muffler, align the opening horizontally and pre-install hand-tight.

2.4.8 Tighten restraining strap (2 ea.).

Tightening torque 15 Nm (11 ftlb.) +/-10 %

2.4.9 Tighten clamping sleeve (Ø 70 x 75, 2 ea.).

Tightening torque 30 Nm (22 ftlb.) +/-10 %

2.5 Install rear bumper (⇒ *Workshop Manual '635019 Removing and installing rear bumper*).

Hexagon-head bolt, M8 x 30 (8 x): **Tightening torque 23 Nm (17 ftlb.)**

3 Convert rear apron

3.1 Remove rear skirt (see also ⇒ *Workshop Manual '636819 Removing and installing rear skirt*).

3.1.1 Remove trim frame for tailpipe cover (left ⇒ *Figure 8*/right)(⇒ *Workshop Manual '637019 Removing and installing trim frame for tailpipe cover*).

1 – Screw, 4.8 x 16

2 – Trim frame for tailpipe cover (left)

3.1.2 Unclip/disengage electric wire harness near the rear skirt and air guide(s).

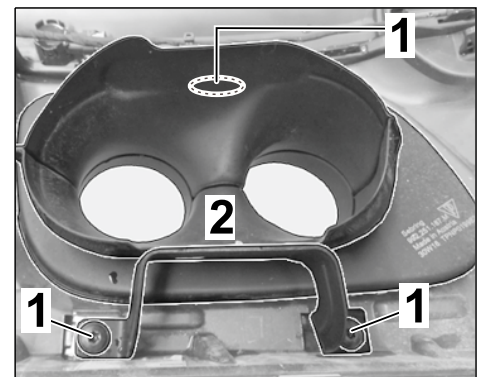

Figure 8

3.1.3 **ONLY** for vehicles WITH Sport-Design package (+ 2D1):

- 1 – Air intake frame (center)
- 2 – Countersunk screw, ST4.8 x 16
- 3 – Oval-head screw, TP6 x 20
- 4 – Air intake frame (left)
- 5 – Painted trim (left)

- Unclip air intake frame (center) (⇒ *Figure 9-1-*)
- Remove countersunk screw, ST4.8 x 16 (1 ea.) and oval-head screw, TP6 x 20 (2 ea.) for painted trim in the air intake frame (left ⇒ *Figure 9-2-/right*)

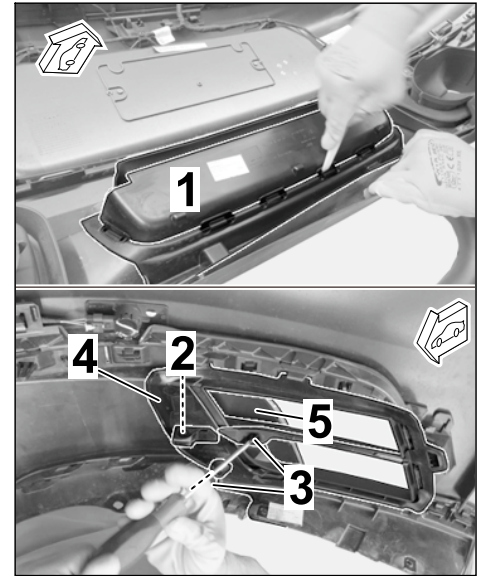

Figure 9

3.1.4 Unclip air intake frame (left ⇒ *Figure 9-4-/right*) from rear skirt.

3.1.5 **ONLY** for vehicles WITH SportDesign package (+ 2D1): Remove painted trim (left ⇒ *Figure 9-3-/right*)

3.1.6 Unclip rear skirt from rear apron.

3.2 Install new rear skirt

3.2.1 Clip new rear skirt into the rear apron (⇒ *Workshop Manual '636819 Removing and installing rear skirt*).

- 3.2.2 **ONLY** for vehicles WITH Sport-Design package (+ 2D1):
- 1 – Painted trim (right)
 - 2 – Rear skirt
- Clip in air intake frame (center) (⇒ *Figure 9-1-*)
 - Clip in painted trim (left/right ⇒ *Figure 10-1-*)

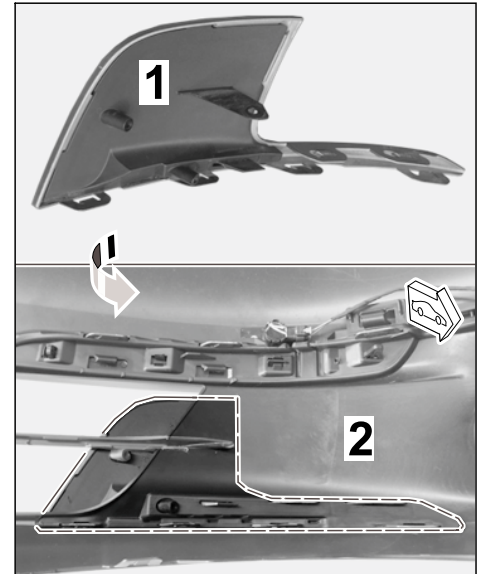

Figure 10

- 3.2.3 Clip air intake frame (left/right) into the rear skirt.

- 3.2.4 **ONLY** for vehicles WITH Sport-Design package (+ 2D1):
- Secure painted trim (left/right) with countersunk screw, ST4.8 x 16 (1 ea.) and oval-head screw, TP6 x 20 (2 ea.).

Countersunk screw, ST4.8 x 16: **Tightening torque 3.2 Nm (2.1 ftlb.)**

Oval-head screw, TP6 x 20: **Tightening torque 3.2 Nm (2.1 ftlb.)**

- 3.2.5 **ONLY** for USA vehicles WITHOUT SportDesign package (- 2D1):
- Remove attachment (at the left/right) from the old rear skirt and install it on the new rear skirt.
- 3.2.6 Clip in/engage electric wire harness near the rear skirt and air guide(s).

- 3.3 Install new exhaust pipe cover in matt black (left/right) (⇒ *Workshop Manual '637019 Removing and installing trim frame for tailpipe cover*).

- 3.3.1 Install new clamping sleeve, St 4.8 x 22 x 18 (3 ea.) on exhaust pipe cover (left ⇒ *Figure 11* /right).

- 1 – Clamping sleeve, St 4.8 x 22 x 18
- 2 – Exhaust pipe cover, Matt Black (left)

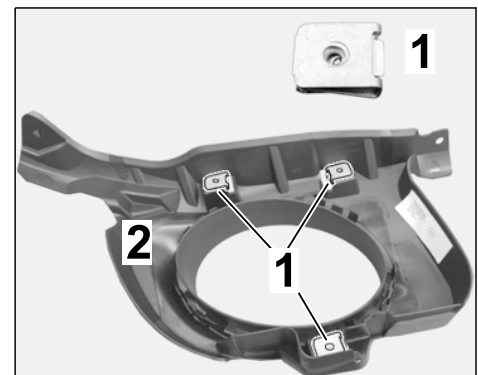

Figure 11

- 3.3.2 Clip exhaust pipe cover in matt black (left/right) into the rear skirt.
- 3.3.3 Install retaining strip for exhaust pipe cover in matt black (left/right)/rear skirt on rear trim panel.

- 3.4 Install new sport tailpipe in black or silver (left/right) (⇒ *Workshop Manual '263519 Removing and installing tailpipe cover*).
- 3.4.1 Install new sport tailpipe (black or silver) hand-tight using new screws (4.8 x 16, 3 ea.) on the relevant exhaust pipe cover in matt black (left/right).
- 3.4.2 Turn the rear apron and check that the gap = "dimension Z" between the new sport tailpipes and exhaust pipe cover (rear apron – left and right side of vehicle) is symmetrically constant (⇒ *Figure 12*).
- Re-align sport tailpipes if necessary.
- 3.4.3 Tighten countersunk screw, ST4.8 x 16 (3 ea.): **Tightening torque 3.2 Nm (2.1 ftlb.)**

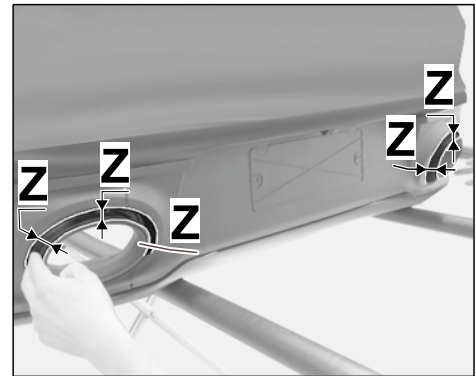

Figure 12

- 4 Concluding mechanical work
- 4.1 Install rear apron (⇒ *Workshop Manual '635519 Removing and installing rear apron*).
- 4.2 Install wheels on rear axle (⇒ *Workshop Manual '440519 Removing and installing wheel*).

Coding: 5 Coding/programming sport exhaust system - Silver (OP8)/Black (OP9)

NOTICE

Voltage drop

- Risk of irreparable damage to control unit
 - Risk of damage to control unit
 - Fault entries in the control unit
 - Coding in the control unit is aborted
 - Malfunctions in control unit, even during programming
- ⇒ Switch off the ignition and remove the ignition key before disconnecting the control unit.
- ⇒ Ensure that the power supply is not interrupted during programming.
- ⇒ Connect a battery charger with a current rating of at least Nominal value 90 A to the vehicle battery.

- 5.1 Preparatory work – Coding

NOTICE

Control unit programming will be aborted if the Internet connection is unstable.

- **An unstable Internet connection can interrupt communication between PIWIS Tester III and the vehicle communication module (VCI). As a result, control unit programming may be aborted.**
- ⇒ **During control unit programming, always connect PIWIS Tester III to the vehicle communication module (VCI) via the USB cable.**

5.1.1 **9900 - PIWIS Tester 3** must be connected to the vehicle and switched on.

5.1.2 Switch on ignition **AND** hazard warning lights on the vehicle.



Information

The **9900 - PIWIS Tester III** instructions take precedence since the description may be different with later Tester releases.

The procedure described here has been structured in general terms; different text or additions may appear on the **9900 - PIWIS Tester III**.

5.1.3 Select the "Diagnostics" menu item on the PIWIS Tester.

5.1.4 If **9900 - PIWIS Tester 3** is connected correctly, a connection to the vehicle will be established: Model line "911" is detected.

5.1.5 Press **•F12** to go to the control unit search screen.

5.1.6 Confirm the question: "Create vehicle analysis log (VAL)?" with "Yes" = **•F12** .



Information

The function is **ONLY** available when the Tester is online!

5.2 Enter the new vehicle equipment in the vehicle data using "PIWIS Online"

5.2.1 Press **•F7** in the control unit overview to switch to the "Additional menu".

5.2.2 Select the function "Maintenance of vehicle data with PIWIS ONLINE".

A message appears informing you that the "Actual" (vehicle) data and "Required" (PIWIS Online) data will be compared.

Press **•F12** to continue.

5.2.3 Confirm the message "The vehicle data was compared with PIWIS Online. Significant differences were found" with **•F12** .

5.2.4 Look for the option "EXHAUST TAILPIPE" in the "Family" column.

Select "OP8 – SPORT EXHAUST SYSTEM – STAINLESS-STEEL TAILPIPES" or "OP9 – SPORT EXHAUST SYSTEM – BLACK TAILPIPES" from the drop-down menu in the "Value" column, depending on the installed option. Press **•F12** to continue.

- 5.2.5 A table containing the coding value and the columns "new value" and "old value" is displayed in the overview. Press •F8" to continue.
- 5.2.6 Data is then written/stored. The following messages appear one after the other:
- Transferring vehicle data to PIWIS Online.
 - Writing and transferring vehicle data to the vehicle.
 - Vehicle order was written successfully.
 - A check was performed in order to check whether control units have to be coded or programmed as a result of the changes that were made.
- 5.3 Code/program the new vehicle equipment.
- 5.3.1 Confirm the table containing a list of control units that must be coded/programmed by pressing •F12" .
- 5.3.2 Individual data records will be loaded, depending on the number of control units to be coded/programmed.
- Wait until the message "Creating backup documentation. Please wait..." and "Coding was completed successfully" appears. Press •F12" to continue.
- Repeat the process for other control units if necessary.
- 5.3.3 Wait until the message "Adaptation of the control units is complete." appears and check the coding status of the control units in the table that is displayed.
- Continue by pressing •F12" to return to the control unit overview.
- 5.4 **ONLY** for vehicles with the following driver assistance systems:
- 5.4.1 Vehicles with Lane Change Assist/Lane Keep Assist (7Y1/P60/P62):
Calibrate control unit for Lane Change Assist (⇒ *Workshop Manual '917025 Calibrating Lane Change Assist'*)
- 5.4.2 Vehicles with ParkAssist including reversing camera (KA2):
Calibrate reversing camera (⇒ *Workshop Manual '914325 Calibrating reversing camera'*).
- 5.4.3 Vehicles with ParkAssist including Surround View (KA6):
Calibrate Surround View camera (⇒ *Workshop Manual '917225 Calibrating Surround View camera'*).
- 5.5 Read out the fault memories of all systems, work through any existing faults and erase the fault memories. ⇒ *Workshop Manual '0335IN Diagnostic maintenance: diagnostic system and maintenance inter...'*
- 5.6 Switch off ignition and disconnect **9900 - PIWIS Tester 3**.
- 5.7 Drive the vehicle off the lifting platform.
- 6 Perform "Sport exhaust system" function test
- 6.1 Start the engine.

6.2 Activate/deactivate the sport exhaust system, depending on vehicle equipment, using the following option:

- Porsche Communication Management: Select the menu "Car" → "Drive" → "Exhaust system"
- Porsche Communication Management: Select "SPORT" or "SPORT PLUS"
- Quick-access button in the keypad (below PCM, see also "911 – Good to know" – "Practical Tips" and "Strip for switches")
- Quick-access button on the multi-function steering wheel (if available, see also "911 – Good to know" – "Practical Tips" and "Instrument cluster")

6.3 Switching off ignition

26 01 31 00: –Sport exhaust system (1 x) retrofitted– Labor time: **293 TU**
 Includes: Removing and installing rear muffler.
 Removing and installing rear apron, bumper and rear skirt.
 Installing and aligning new sport tailpipes (2 x).
 Without: Test drive

03 35 00 50: –On-board diagnosis– Labor time: **12 TU**
 Includes: Coding sport exhaust system (I-no. OP8 or I-no. OP9) in the vehicle data using the PIWIS Tester.

Additional working times: **ONLY** for vehicles with Lane Change Assist/Lane Keep Assist (7Y1/P60/P62):
 97 70 25 53: Programming Lane Change Assist control unit. Labor time: **47 TU**
 Includes: Calibrating calibration plate on the vehicle.

ONLY for vehicles with ParkAssist including reversing camera (KA2):
 91 43 25 53: Programming reversing camera Labor time: **49 TU**

ONLY for vehicles with ParkAssist including Surround View (KA6):
 91 72 25 50: Programming Surround View camera control unit Labor time: **45 TU**

Important Notice: Technical Bulletins issued by Porsche Cars North America, Inc. are intended only for use by professional automotive technicians who have attended Porsche service training courses. They are written to inform those technicians of conditions that may occur on some Porsche vehicles, or to provide information that could assist in the proper servicing of a vehicle. Porsche special tools may be necessary in order to perform certain operations identified in these bulletins. Use of tools and procedures other than those Porsche recommends in these bulletins may be detrimental to the safe operation of your vehicle, and may endanger the people working on it. Properly trained Porsche technicians have the equipment, tools, safety instructions, and know-how to do the job properly and safely. Part numbers listed in these bulletins are for reference only. The work procedures updated electronically in the Porsche PIWIS diagnostic and testing device take precedence and, in the event of a discrepancy, the work procedures in the PIWIS Tester are the ones that must be followed.

© 2020 Porsche Cars North America, Inc.