



Service Bulletin

Bulletin No.: 20-NA-040

Date: March, 2020

TECHNICAL

Subject: Pickup Box Power Endgate May Not Open on Initial Press, or May Not Open at All

Brand:	Model:	Model Year:		Date Breakpoint:		Engine:	Transmission:
		from	to	from	to		
Chevrolet	Silverado 1500 (New Model)	2019	2019			All	All
	Silverado 1500 (New Model - 12th VIN Digit = 7) - 4WD						
GMC	Sierra 1500 (New Model)						
Chevrolet	Silverado 1500	2020	2020	SOP	April 1, 2020		
	Silverado 2500HD/3500HD						
GMC	Sierra 1500						
	Sierra 2500HD/3500HD						

Involved Region or Country	North America, Europe, Russia, Middle East, Israel, Palestine, South America, Philippines, Australia, New Zealand, Egypt, Africa, South Africa
Additional Options (RPOs)	Equipped with QK1 and QK5
Condition	Some customers may comment on the power endgate may not unlatch or drop on first try, or under some conditions, it may not open at all.
Cause	The cause of the condition may be a combination of excessive spring force and low available voltage, which may cause the latch actuator to fail to function.
Preliminary Procedure	<p>Some vehicles, which have a tonneau cover installed, may be affected by a similar Condition, however the Cause and Correction are completely different from this bulletin. On these vehicles, it will be necessary rule out the tonneau cover as the possible Cause of the condition:</p> <ol style="list-style-type: none"> 1. Open the rear end panel of the tonneau cover. 2. Cycle the power tailgate 5 times using push button activation for auto open and auto close. <ul style="list-style-type: none"> • If the power endgate Does function properly, DO NOT proceed with this bulletin repair, but move on to Bulletin # 20-NA-044 and complete the tonneau adjustment procedure. • If the power endgate still DOES NOT function properly, continue on and complete the Correction outlined in this bulletin.

Correction

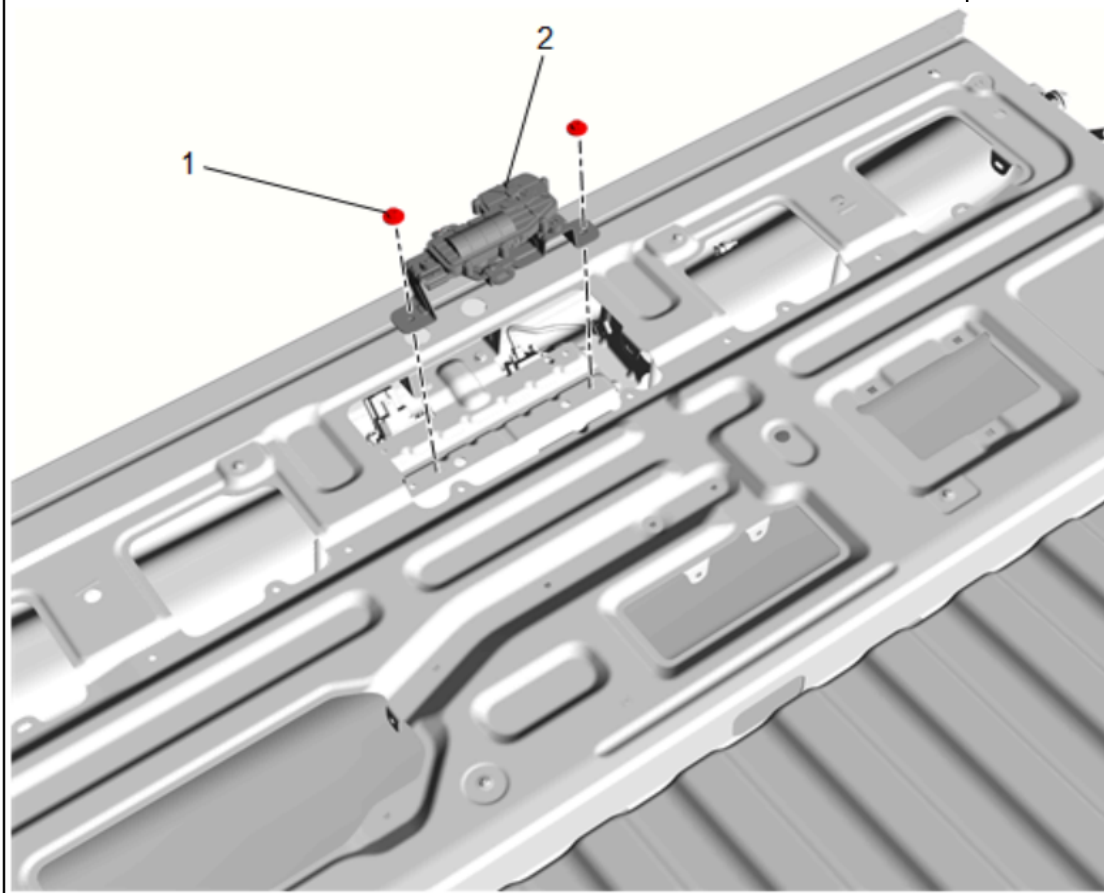

5049815

Upon verifying the condition, replace the pickup box endgate lock actuator (2) with an improved design service part. Refer to *Pickup Box Endgate Lock Actuator Replacement (Power)* in SI.

Service Procedure

Parts Information

Causal Part	Description	Part Number	Qty
X	ACTUATOR ASM-PUBX E/ GATE LK	84873070	1

Warranty Information

For vehicles repaired under the Bumper-to-Bumper coverage (Canada Base Warranty coverage), use the following labor operation. Reference the Applicable Warranties section of Investigate Vehicle History (IVH) for coverage information.

Labor Operation	Description	Labor Time
2086078*	Pickup Box Endgate Lock Power Actuator Replacement	0.4 hr
*This is a unique Labor Operation for Bulletin use only.		

Version	1
Modified	Released February 26, 2020

