

# Service Action

## Code: 93F1



<b>Subject</b>	<b>High-Voltage Battery</b>														
<b>Release Date</b>	March 12, 2020														
<b>Affected Vehicles</b>	<table border="1"> <thead> <tr> <th>Country</th> <th>Beginning Model Year</th> <th>Ending Model Year</th> <th>Vehicle</th> <th>Vehicle Count</th> </tr> </thead> <tbody> <tr> <td>USA</td> <td>2016</td> <td>2016</td> <td>A3 ETRON</td> <td>1,764</td> </tr> </tbody> </table>					Country	Beginning Model Year	Ending Model Year	Vehicle	Vehicle Count	USA	2016	2016	A3 ETRON	1,764
Country	Beginning Model Year	Ending Model Year	Vehicle	Vehicle Count											
USA	2016	2016	A3 ETRON	1,764											
	<p>Check Campaigns/Actions screen in Elsa on the day of repair to verify that a VIN qualifies for repair under this action. Elsa is the <u>only</u> valid campaign inquiry &amp; verification source.</p> <ul style="list-style-type: none"> <li>✓ Campaign status must show “open.”</li> <li>✓ If Elsa shows other open action(s), inform your customer so that the work can also be completed at the same time the vehicle is in the workshop for this campaign.</li> </ul>														
<b>Problem Description</b>	It is possible that the high-voltage battery housing bonded seam was made in a non-optimal position. If this condition is present, moisture can enter the high-voltage battery housing. The driver may be alerted to this condition by the illumination of a high-voltage system warning indicator on the instrument cluster display.														
<b>Corrective Action</b>	Disassemble and inspect the high-voltage battery for corrosion. If no corrosion is found, install a new high-voltage battery housing. If corrosion is found, the high-voltage battery will be replaced.														
<b>WARNING! HIGH-VOLTAGE VEHICLE</b>	<b>This repair must only be performed by authorized Audi dealership technicians that have the proper tools, training and certification to conduct repairs on high-voltage vehicles.</b>														
<b>Precautions</b>	<p>Ensure all vehicle drivers have read the vehicle owner’s manual so they are familiar with how the high-voltage battery system and associated warning lights work.</p> <p>Please be aware that other conditions (unrelated to the issue described in this circular) may cause a high-voltage battery system-related warning light in the vehicle to illuminate. Customers should be prepared to cover diagnosis and repair costs associated with these other, unrelated conditions.</p>														
<b>Code Visibility</b>	On or about March 12, 2020, the campaign code will be applied to affected vehicles.														
<b>Owner Notification</b>	Owner notification will take place in February 2020. Owner letter examples are included in this bulletin for your reference.														
<b>Campaign Expiration Date</b>	This campaign expires on <b>December 31, 2022</b> . Repairs must be performed on or before this date to be eligible for payment. Keep this expiration date in mind when scheduling customers for this action. If a customer wishes to have this service performed after the expiration date, your dealerships normal parts and labor cost associated with this repair will apply.														
<b>Additional Information</b>	<p><b>Please alert everyone in your dealership about this action, including Sales, Service, Parts and Accounting personnel. Contact Warranty if you have any questions.</b></p> <p>Dealers must ensure that every affected inventory vehicle has this campaign completed <u>before delivery to consumers</u>.</p>														

Parts Information

<b>Parts Control Type:</b> <b>VIN to ORDER</b>	<p>Due to the small number of affected vehicles there will not be a parts allocation. Please reference the Repair Projection Tool below to view your potential VIN population.</p> <p>If parts are needed to support a vehicle repair:</p> <ul style="list-style-type: none"> <li>• US Dealers - use AVA</li> <li>• CAN Dealers - contact the Parts Specialists via phone (800-767-6552), email (<a href="mailto:VWoAPartsSpecialists@vw.com">VWoAPartsSpecialists@vw.com</a>), or chat/text with the VIN to order</li> </ul>
---	---

<b>Repair Projection Tool:</b> <b>Right click to open</b>	
--	---

Criteria	Quantity	Part Number	P.O.C. Part Description	Ordering Method
01	1	5Q0-998-844	Battery housing repair kit	VIN to Order
	3	N 907-726-01	Cable holder	VIN to Order
	1	1K0-253-115-M	Muffler gasket	VIN to Order
	2	N -022-146-9	Nuts - Exhaust	VIN to Order
	2	5Q0-201-449-AE	Fuel line retaining clip	VIN to Order
	2	D -190-000-M2	Adhesive	VIN to Order
	1	D -181-220-A1	Primer (30 minute flash off time)	VIN to Order
	0.5	D -355-205-A2	Bonding agent (bottom)	VIN to Order
	3	D -009-500-25	Applicator	VIN to Order
	0.25	D -469-101-A3	Butyl adhesive	VIN to Order
	3.0 L	SEE ETKA	Coolant	See Parts on Command
	1	5Q0-121-809-A	Lead seal	VIN to Order
	1	12E-010-006	Warning label (English)	VIN to Order
	1	12E-010-006-A	Warning label (French)	VIN to Order
1	5Q0-998-590-A*	High-voltage battery (*ONLY IF CORROSION IS FOUND ON BATTERY MODULES)	VIN to Order	

 <b>NOTE</b>
The specified part numbers reflect the status at the start of this service action. Interim updates made in ETKA can cause a listed part number to become unavailable. In this case, the new part number specified in ETKA should be used.

The information in this document is intended for use only by skilled technicians who have the proper tools, equipment and training to correctly and safely maintain your vehicle. These procedures are not intended to be attempted by "do-it-yourselfers," and you should not assume this document applies to your vehicle, or that your vehicle has the condition described. To determine whether this information applies, contact an authorized Audi dealer. ©2020 Audi Group of America, Inc. and Audi Canada. All Rights Reserved.

### Claim Entry Instructions

After campaign has been completed, enter claim as soon as possible to help prevent work from being duplicated elsewhere. Attach the Elsa screen print showing action open on the day of repair to the repair order.

If customer refused campaign work:

- ✓ U.S. dealers: Submit the request through Audi Warranty Online under the Campaigns/Update option.
- ✓ Canada dealers: Upload the repair order [signed by customer] to Audi WIN/Operations/Campaign Closure.

<b>Service Number</b>	93F1																																										
<b>Damage Code</b>	0099																																										
<b>Parts Vendor Code</b>	002																																										
<b>Claim Type</b>	Sold vehicle: 7 10 Unsold vehicle: 7 90																																										
<b>Causal Indicator</b>	Mark Repair kit for battery housing or High-voltage battery as causal*																																										
<b>Vehicle Wash/Loaner</b>	Do not claim wash or loaner.																																										
<b>Criteria I.D.</b>	01																																										
	<p>Inspect battery modules for corrosion; no corrosion found, replace high-voltage battery housing.</p> <p>Labor operation:      9302 55 99                      935 T.U.</p> <table border="1"><thead><tr><th>Quantity</th><th>Part Number</th><th>Description</th></tr></thead><tbody><tr><td>1.00</td><td>5Q0998844</td><td>Repair kit for battery housing*</td></tr><tr><td>1.00</td><td>12E010006</td><td>Warning sign (English)</td></tr><tr><td>1.00</td><td>12E010006A</td><td>Warning sign (French)</td></tr><tr><td>1.00</td><td>1K0253115M</td><td>Gasket</td></tr><tr><td>2.00</td><td>5Q0201449AE</td><td>Securing clip</td></tr><tr><td>3.00</td><td>D 00950025</td><td>Applicator</td></tr><tr><td>1.00</td><td>D 181220A1</td><td>Primer</td></tr><tr><td>2.00</td><td>D 190000M2</td><td>Adhesive</td></tr><tr><td>0.50</td><td>D 355205A2</td><td>Bonding agent</td></tr><tr><td>0.30</td><td>D 469101A3</td><td>Butyl adhesive</td></tr><tr><td>Up to 30.00</td><td>G 013A8JS0</td><td>Coolant</td></tr><tr><td>2.00</td><td>N 0221469</td><td>Nut</td></tr><tr><td>3.00</td><td>N 90772601</td><td>Tie wrap</td></tr></tbody></table> <p>-OR-</p>	Quantity	Part Number	Description	1.00	5Q0998844	Repair kit for battery housing*	1.00	12E010006	Warning sign (English)	1.00	12E010006A	Warning sign (French)	1.00	1K0253115M	Gasket	2.00	5Q0201449AE	Securing clip	3.00	D 00950025	Applicator	1.00	D 181220A1	Primer	2.00	D 190000M2	Adhesive	0.50	D 355205A2	Bonding agent	0.30	D 469101A3	Butyl adhesive	Up to 30.00	G 013A8JS0	Coolant	2.00	N 0221469	Nut	3.00	N 90772601	Tie wrap
Quantity	Part Number	Description																																									
1.00	5Q0998844	Repair kit for battery housing*																																									
1.00	12E010006	Warning sign (English)																																									
1.00	12E010006A	Warning sign (French)																																									
1.00	1K0253115M	Gasket																																									
2.00	5Q0201449AE	Securing clip																																									
3.00	D 00950025	Applicator																																									
1.00	D 181220A1	Primer																																									
2.00	D 190000M2	Adhesive																																									
0.50	D 355205A2	Bonding agent																																									
0.30	D 469101A3	Butyl adhesive																																									
Up to 30.00	G 013A8JS0	Coolant																																									
2.00	N 0221469	Nut																																									
3.00	N 90772601	Tie wrap																																									

**If high-voltage battery requires replacement then three (3) separate claims will need to be entered.**

- Claim 1 must be entered once the repair is completed.
- Claims 2 and 3 may be entered once an invoice is received for the transportation and recycling of the high-voltage battery.

<b>Claim 1:</b>	Labor operation:      9303 55 99                                  600 T.U.  Inspect battery modules for corrosion; corrosion is found, replace high-voltage battery  <table border="1" style="width: 100%; border-collapse: collapse; margin-bottom: 10px;"> <thead> <tr> <th style="width: 15%;">Quantity</th> <th style="width: 30%;">Part Number</th> <th style="width: 55%;">Description</th> </tr> </thead> <tbody> <tr> <td>1.00</td> <td>5Q0998590A</td> <td>High-voltage battery*</td> </tr> <tr> <td>1.00</td> <td>12E010006</td> <td>Warning sign (English) – if necessary</td> </tr> <tr> <td>1.00</td> <td>12E010006A</td> <td>Warning sign (French) – if necessary</td> </tr> <tr> <td>1.00</td> <td>1K0253115M</td> <td>Gasket</td> </tr> <tr> <td>0.30</td> <td>D 469101A3</td> <td>Butyl adhesive</td> </tr> <tr> <td>2.00</td> <td>N 0221469</td> <td>Nut</td> </tr> </tbody> </table> -AND-  <b>OUTSIDE MATERIAL (if required)</b>  <table border="1" style="width: 100%; border-collapse: collapse;"> <thead> <tr> <th style="width: 15%;">Quantity</th> <th style="width: 15%;">Part (tool) Number</th> <th style="width: 45%;">Description</th> <th style="width: 25%;">Amount</th> </tr> </thead> <tbody> <tr> <td>Up to 12.00</td> <td>T10544</td> <td>HV Terminal sealing cap</td> <td>\$4.88 each (max. \$58.56)</td> </tr> </tbody> </table>	Quantity	Part Number	Description	1.00	5Q0998590A	High-voltage battery*	1.00	12E010006	Warning sign (English) – if necessary	1.00	12E010006A	Warning sign (French) – if necessary	1.00	1K0253115M	Gasket	0.30	D 469101A3	Butyl adhesive	2.00	N 0221469	Nut	Quantity	Part (tool) Number	Description	Amount	Up to 12.00	T10544	HV Terminal sealing cap	\$4.88 each (max. \$58.56)
Quantity	Part Number	Description																												
1.00	5Q0998590A	High-voltage battery*																												
1.00	12E010006	Warning sign (English) – if necessary																												
1.00	12E010006A	Warning sign (French) – if necessary																												
1.00	1K0253115M	Gasket																												
0.30	D 469101A3	Butyl adhesive																												
2.00	N 0221469	Nut																												
Quantity	Part (tool) Number	Description	Amount																											
Up to 12.00	T10544	HV Terminal sealing cap	\$4.88 each (max. \$58.56)																											
<b>Claim 2:</b>	Transportation Cost of High-Voltage Battery  <table border="1" style="width: 100%; border-collapse: collapse;"> <tr> <td style="width: 50%;"><b>Claim Type:</b></td> <td style="width: 25%;">7-MO</td> <td style="width: 25%;"></td> </tr> <tr> <td><b>Service Number:</b></td> <td>93F1</td> <td></td> </tr> <tr> <td><b>Damage Code:</b></td> <td>0010</td> <td></td> </tr> <tr> <td><b>Parts Vendor Code:</b></td> <td>002</td> <td></td> </tr> <tr> <td><b>Outside Labor Operation:</b></td> <td>S371 00 PF</td> <td>Retain invoice as proof.</td> </tr> </table>	<b>Claim Type:</b>	7-MO		<b>Service Number:</b>	93F1		<b>Damage Code:</b>	0010		<b>Parts Vendor Code:</b>	002		<b>Outside Labor Operation:</b>	S371 00 PF	Retain invoice as proof.														
<b>Claim Type:</b>	7-MO																													
<b>Service Number:</b>	93F1																													
<b>Damage Code:</b>	0010																													
<b>Parts Vendor Code:</b>	002																													
<b>Outside Labor Operation:</b>	S371 00 PF	Retain invoice as proof.																												
<b>Claim 3:</b>	Recycling Costs of High-Voltage Battery (if required)  <table border="1" style="width: 100%; border-collapse: collapse;"> <tr> <td style="width: 50%;"><b>Claim Type:</b></td> <td style="width: 25%;">7-MO</td> <td style="width: 25%;"></td> </tr> <tr> <td><b>Service Number:</b></td> <td>93F1</td> <td></td> </tr> <tr> <td><b>Damage Code:</b></td> <td>0010</td> <td></td> </tr> <tr> <td><b>Parts Vendor Code:</b></td> <td>002</td> <td></td> </tr> <tr> <td><b>Outside Labor Operation:</b></td> <td>S371 00 PG</td> <td>Retain invoice as proof.</td> </tr> </table>	<b>Claim Type:</b>	7-MO		<b>Service Number:</b>	93F1		<b>Damage Code:</b>	0010		<b>Parts Vendor Code:</b>	002		<b>Outside Labor Operation:</b>	S371 00 PG	Retain invoice as proof.														
<b>Claim Type:</b>	7-MO																													
<b>Service Number:</b>	93F1																													
<b>Damage Code:</b>	0010																													
<b>Parts Vendor Code:</b>	002																													
<b>Outside Labor Operation:</b>	S371 00 PG	Retain invoice as proof.																												

The repair information in this document is intended for use only by skilled technicians who have the proper tools, equipment and training to correctly and safely maintain your vehicle. These procedures are not intended to be attempted by "do-it-yourselfers," and you should not assume this document applies to your vehicle, or that your vehicle has the condition described. To determine whether this information applies, contact an authorized Audi dealer. ©2020 Audi of America, Inc. and Audi Canada. All Rights Reserved.

## Customer Letter Example (USA)

This notice applies to your vehicle: <MODEL YEAR> <BRAND> <CARLINE>, <VIN>

**Subject: Service Action 93F1 – High-Voltage Battery  
Certain 2016 Model Year Audi A3 e-tron Vehicles**

Dear Audi Owner,

As part of Audi's ongoing commitment to customer satisfaction, we are informing you of our decision to conduct a service action on certain 2016 model year Audi A3 e-tron vehicles. Our records show that you are the owner of a vehicle affected by this action.

**What is the issue?** It is possible that the high-voltage battery housing bonded seam was made in a non-optimal position. If this condition is present, moisture can enter the high-voltage battery housing. The driver may be alerted to this condition by the illumination of a high-voltage system warning indicator on the instrument cluster display.

**What will we do?** Your authorized Audi dealer will disassemble and inspect the high-voltage battery for corrosion.

- If no corrosion is found, your dealer will install a new high-voltage battery housing, which may take up to two days to complete.
- If corrosion is found, the high-voltage battery will be replaced. Your dealer will order the new battery for your vehicle, and once it arrives at the dealership the replacement may take up to two days to complete.

Both the inspection and replacement (if necessary) will be performed for you free of charge.

**Precautions You Should Take** Ensure all vehicle drivers have read the vehicle owner's manual so they are familiar with how the high-voltage battery system and associated warning lights work.

Please be aware that other conditions (unrelated to the issue described in this circular) may cause a high-voltage battery system-related warning light in the vehicle to illuminate. Customers should be prepared to cover diagnosis and repair costs associated with these other, unrelated conditions.

**What should you do?** In order to limit any possible inconvenience, please contact your authorized Audi dealer as soon as possible to schedule this service. Please keep in mind that your dealer may need additional time for the preparation of the repair, as well as to accommodate their daily workshop schedule. For your convenience, you can also visit [www.audiusa.com](http://www.audiusa.com) and click on the "Find a Dealer" link to locate a dealer near you and schedule this service.

This service action will be available for you free of charge only until December 31, 2022. If you wish to have this service performed after that date, your dealer's normal parts and labor cost associated with this repair will apply.

**Lease vehicles and address changes** If you are the lessor and registered owner of the vehicle identified in this action, please forward this letter immediately via first-class mail to the lessee within ten (10) days of receipt. If you have changed your address or sold the vehicle, please fill out the enclosed prepaid Owner Reply card and mail it to us so we can update our records.

**Can we assist you further?** If your authorized Audi dealer fails or is unable to complete this work free of charge within a reasonable time, please contact Audi Customer Experience at 1-800-253-2834 or via our "Contact Us" page at [www.audiusa.com](http://www.audiusa.com).

**Checking your vehicle for open Recalls and Service Campaigns** To check your vehicle's eligibility for repair under this or any other recall/service campaign, please visit the **Recall/Service Campaign Lookup** tool at [www.audiusa.com](http://www.audiusa.com) and enter your Vehicle Identification Number (VIN).

We apologize for any inconvenience this matter may cause; however we are taking this action to help ensure your vehicle continues to meet and exceed your expectations.

Sincerely,

Audi Customer Protection

## Customer Letter Example (CANADA)

This notice applies to your vehicle: <MODEL YEAR> <BRAND> <CARLINE>, <VIN>

**Subject: Service Action 93F1 – High-Voltage Battery  
Certain 2016 Model Year Audi A3 e-tron Vehicles**

Dear Audi Owner,

As part of Audi's ongoing commitment to customer satisfaction, we are informing you of our decision to conduct a service action on certain 2016 model year Audi A3 e-tron vehicles. Our records show that you are the owner of a vehicle affected by this action.

**What is the issue?** It is possible that the high-voltage battery housing bonded seam was made in a non-optimal position. If this condition is present, moisture can enter the high-voltage battery housing. The driver may be alerted to this condition by the illumination of a high-voltage system warning indicator on the instrument cluster display.

**What will we do?** Your authorized Audi dealer will disassemble and inspect the high-voltage battery for corrosion.

- If no corrosion is found, your dealer will install a new high-voltage battery housing, which may take up to two days to complete.
- If corrosion is found, the high-voltage battery will be replaced. Your dealer will order the new battery for your vehicle, and once it arrives at the dealership the replacement may take up to two days to complete.

Both the inspection and replacement (if necessary) will be performed for you free of charge.

**Precautions You Should Take** Ensure all vehicle drivers have read the vehicle owner's manual so they are familiar with how the high-voltage battery system and associated warning lights work.

Please be aware that other conditions (unrelated to the issue described in this circular) may cause a high-voltage battery system-related warning light in the vehicle to illuminate. Customers should be prepared to cover diagnosis and repair costs associated with these other, unrelated conditions.

**What should you do?** In order to limit any possible inconvenience, please contact your authorized Audi dealer as soon as possible to schedule this service. Please keep in mind that your dealer may need additional time for the preparation of the repair, as well as to accommodate their daily workshop schedule.

This service action will be available for you free of charge only until December 31, 2022. If you wish to have this service performed after that date, your dealer's normal parts and labor cost associated with this repair will apply.

**Lease vehicles and address changes** If you are the lessor and registered owner of the vehicle identified in this action, please forward this letter immediately via first-class mail to the lessee within ten (10) days of receipt. If you have changed your address or sold the vehicle, please fill out the enclosed prepaid Owner Reply card and mail it to us so we can update our records.

**Can we assist you further?** If your authorized Audi dealer fails or is unable to complete this work free of charge within a reasonable time, please contact Audi Customer Relations Monday through Friday from 8AM to 8PM EST at 1-800-822-2834 or via our "Contact Audi Canada" page at [www.audi.ca](http://www.audi.ca).

We apologize for any inconvenience this matter may cause; however we are taking this action to help ensure your vehicle continues to meet and exceed your expectations.

Sincerely,

Audi Customer Protection

## NOTE

- These repair instructions may differ from the labor operations and labor times listed in ELSA.
- Damages resulting from improper repair or failure to follow these work instructions are the dealer's responsibility and are not eligible for reimbursement under this action.
- This procedure must be read in its entirety prior to performing the repair.
- Due to variations in vehicle equipment and options, the steps/illustrations in this work procedure may not identically match all affected vehicles.
- Diagnosis and repair of pre-existing conditions in the vehicle are not covered under this action.
- When working during extreme temperatures, it is recommended that the vehicle be allowed to acclimate inside the shop to avoid temperature-related component damage/breakage.

## Repair Overview



- Inspect for evidence of water, moisture or corrosion in high-voltage battery housing and:
  - Replace High-voltage battery housing
  - OR-**
  - Replace High-voltage battery

- Section A – Check for Previous Repair
- Section B – High-voltage Battery Removal From Vehicle
- Section C – High-voltage Battery Inspection Overview
- Section D – Opening High-Voltage Battery Housing
  - Subsection 1 - Removing High-voltage Battery Module Group
  - Subsection 2 - Preparing New Battery Housing
  - Subsection 3 - Reinstalling Battery Module Group Into Battery Housing
  - Subsection 4 - Sealing Battery Housing
- Section E – High-voltage Battery Replacement
- Section F – Reinstalling High-voltage Battery Into Vehicle
- Section G – Campaign Completion Stamp
- Section H – Parts Return
- Appendix A – Cooling System Tester Self-Test

- Appendix B - Cooling System Leak Test
- Appendix C - VAS6911/3A Self-Test
- Appendix D – High-voltage Battery Acclimation Test
- Appendix E – High-voltage Battery Pressure Test
- Appendix F – Bolt Torque Sequence
- Appendix G – A3 Battery Portal Instructions (U.S. Dealers Only)



## Required Parts

<u>Criteria</u>	<u>Quantity</u>	<u>Part Number</u>	<u>Part Description</u>
01	1	5Q0.998.844	Battery housing repair kit
	3	N 907.726.01	Cable holder
	1	1K0.253.115.M	Muffler gasket
	2	N 022.146.9	Nuts - Exhaust
	2	5Q0.201.449.AE	Fuel line retaining clip
	2	D 190.000.M2	Adhesive
	1	D 181.220.A1	Primer (30 minute flash off time)
	0.5	D 355.205.A2	Bonding agent (bottom)
	3	D 009.500.25	Applicator
	0.25	D 469.101.A3	Butyl adhesive
	3.0 L	SEE ETKA	Coolant
	1	5Q0.121.809.A	Lead seal
	1	12E.010.006	Warning label (English)
	1	12E.010.006.A	Warning label (French)
	1	5Q0.998.590.A*	High-voltage battery (*ONLY IF CORROSION IS FOUND ON BATTERY MODULES)

### ! NOTE

The specified part numbers reflect the status at the start of this service action. Interim updates made in ETKA can cause a listed part number to become unavailable. In this case, the new part number specified in ETKA should be used.

## Battery Housing Repair Kit Contents

Position	Qty.	Description	Bag Number / Description	ETKA Part Number
<b>1</b>	2	Coolant pipe connecting piece	QVC5KF000030 / Sealing Plug	5Q0.915.373.B
<b>2</b>	2	Bolts - Battery housing cover, center (black)	QVC5LE000940 / M6 – 12 bolt	N/A
<b>3</b>	2	Washers - Battery housing cover bolts	QVC5LE000870 / Washer 6.4x30x1.5	N/A
<b>4</b>	4	Bolts – J840 to battery housing (bottom section)	QVC5LE001000 / M6 – 25 bolt	N 106.321.02
<b>5</b>	1	Gasket – J840 to battery housing (bottom section)	QVC5KF000050 / BMC Housing Gasket	5Q0.915.433
<b>6</b>	2	Pressure relief plugs	QVC5KG000010 / Breather Membrane	5Q0.998.841.B
<b>7</b>	18	Bolts – Battery housing cover, perimeter	QVC5LE001730 / SPL SCR M6X26 WASHER	N/A
<b>8</b>	2	Battery housing cover seals	QVC5KF000060 / Gasket Carrier Modul	N/A
<b>9</b>	2	Bolts – SX6 cables to lower battery housing (silver)	QVC5LE000500 / SPL SCR PAN FL M8-16	5Q0.998.215.A
<b>10</b>	24	Bolts – Battery module group to lower battery housing (M8 x 30)	N/A	WHT.008.861

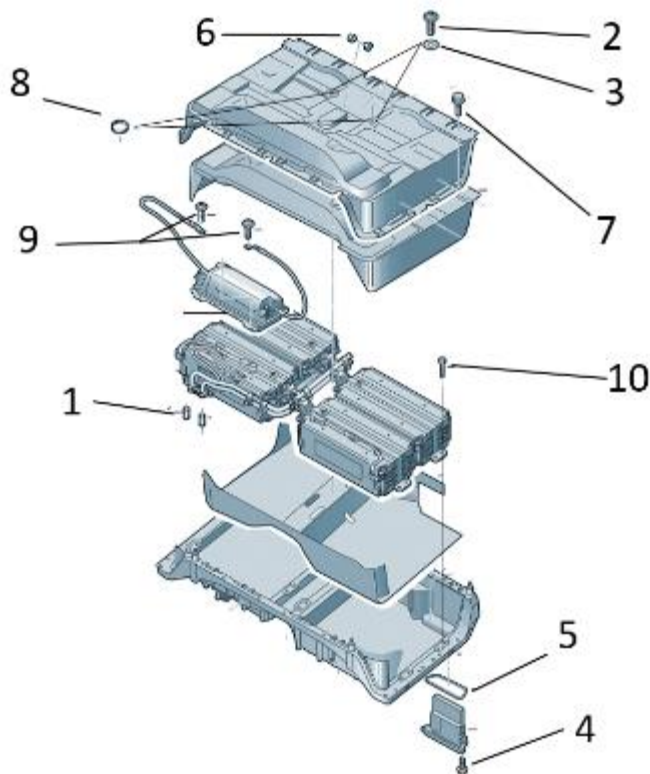

The repair information in this document is intended for use only by skilled technicians who have the proper tools, equipment and training to correctly and safely maintain your vehicle. These procedures are not intended to be attempted by "do-it-yourselfers," and you should not assume this document applies to your vehicle, or that your vehicle has the condition described. To determine whether this information applies, contact an authorized Audi dealer. ©2020 Audi of America, Inc. and Audi Canada. All Rights Reserved.

## Required Tools

 <p>Trim Removal Wedge -3409- (or equivalent)</p>	 <p>Adapter -T10542A-</p>
 <p>Holding Strap -T40155(A)- (qty. 2)</p>	 <p>Padlock -T40262/1- (from Service Disconnect Lock -T40262-)</p>
 <p>Cooling System Tester -VAG1274B-</p>	 <p>Digital Pressure Sensor -VAG1397B(A)-</p>
 <p>Electric Cutter -VAG1561A-</p>	 <p>Shop Crane -VAS6100- (or equivalent)</p>
 <p>Pressure Gauge -VAS611013-</p>	 <p>Scissor Lift Table - Audi Set -VAS6131/10-</p>

 <p>Parts for Scissor Lift Table - Q7 Set:  /13-4 2X  /13-2 4X  /13-1 2X  /13-5  /13-6  /13-7  /10-2 3X  /13-3</p>	 <p>Scissor Lift Table  -VAS6131B-</p>
 <p>Pneumatic Gun - 10 Bar  -VAS6648-</p>	 <p>Warning Sign - High Voltage  -VAS6649-</p>
 <p>Warning Sign - "Do Not Switch On"  -VAS6650A-</p>	 <p>Warning Sign - Battery  -VAS6786-</p>
 <p>Warning Sign - "Do Not Enter"  -VAS6881-</p>	 <p>Parts for Cooling System Tester:  /1  /5  /2 x 2  /3 x 2  /4</p> <p>Cooling System Tester for High Voltage Batteries  -VAS691005-</p>
 <p>Shackle  -VAS691009-</p>	 <p>Rubber Bung  -VAS6911/15-</p>

	<p>Leak Tester - Test Connector Set -VAS6911/3A-</p>		<p>Suspension Device -T10543-</p>
	<p>High Voltage Tool Set -VAS6762-</p>		<p>High-Voltage Battery Repair Tool Set - Cutter - 27mm -VAS6900/1-</p>
	<p>High-Voltage Battery Repair Tool Set - Levering Tool -VAS6900/6-</p>		<p>High Voltage Tool Set - Torque Wrench -VAS6883/1A-</p>
	<p>Insulated Torx Wrench Set - 3/8- -VAS691003A-</p>		<p>Drip Tray -VAS6208- (or equivalent)</p>
	<p>High-voltage cordon -VAS6884-</p>		<p>Guide Sleeves -VAS691005/9-</p>
	<p>Test Adapter - Hybrid Module -VAS6558A-</p>		<p>Diagnostic Box -VAS5581-</p>

The repair information in this document is intended for use only by skilled technicians who have the proper tools, equipment and training to correctly and safely maintain your vehicle. These procedures are not intended to be attempted by "do-it-yourselfers," and you should not assume this document applies to your vehicle, or that your vehicle has the condition described. To determine whether this information applies, contact an authorized Audi dealer. ©2020 Audi of America, Inc. and Audi Canada. All Rights Reserved.

**⚠ CAUTION**

**Replacing battery housing:**

The work must be performed by a high-voltage expert (HVE) or high-voltage technician (HVT) who has received additional training (Replacing A3 etron housing in accordance with campaign instructions).

**If moisture is found in high-voltage battery:**

Work must be performed by high-voltage expert (HVE).

**Safety Precautions When Working ON the High-voltage System (additional information is also available in the ELSA Repair Manual)**

**⚠ DANGER**

**High-voltage can cause fatal injury**

- The voltage levels in the high-voltage system constitute a safety hazard. Danger of severe or fatal injuries from electric shock.
- Persons with life-sustaining or other electronic medical devices in or on their body must not perform any work on the high-voltage system. Such medical devices include internal analgesic pumps, implanted defibrillators, pacemakers, insulin pumps and hearing aids.
- The high-voltage system must be de-energized by a suitably qualified person.

**⚠ DANGER**

**There Is a Risk of Explosion Caused by Cooling System Leaks in the High-Voltage Battery. This Can Cause a Buildup of Explosive Gases in the Battery Housing.**

- Explosions May Cause Severe Bodily Injuries.
- Loss of coolant indicates there could be a coolant leak internal to the high-voltage battery housing.
- If the indicator lights for “coolant level” and “high-voltage battery error” turn on, move the vehicle into the open air into the defined separate parking area.
- Notify the high-voltage expert (HVE).

**⚠ WARNING**

**Risk of injury - motor may start unexpectedly**

It is difficult to determine whether the drive system of an electric vehicle or hybrid vehicle is active. Moving parts can trap or draw in parts of the body.

**⚠ CAUTION**

**Risk of damage to high-voltage wiring**

Incorrect handling may result in damage to the insulation of high-voltage wires or high-voltage connectors.

- Do not support yourself on high-voltage cables or connectors.
- Never prop tools against high-voltage wiring or high-voltage connectors.
- Never bend or kink high-voltage wiring.
- Observe the coding of the high-voltage connectors when joining them up.

## Safety Precautions When Working IN THE VICINITY of the High-voltage System (additional information is also available in the ELSA Repair Manual)

### DANGER

#### High-voltage can cause fatal injury

- The voltage levels in the high-voltage system constitute a safety hazard. Danger of severe or fatal injuries from electric shock if high-voltage components or high-voltage wiring are damaged.
- Carry out a visual check of high-voltage components and high-voltage wiring.
- Never use cutting/forming tools or other sharp-edged implements.
- Never perform work using welding, brazing, thermal bonding or hot air.

## Repair Instruction

### Section A - Check for Previous Repair

Applicable criteria ID(s)	Campaign/Action Status
01 ← <b>2</b>	Open ← <b>1</b>

**EXAMPLE**

- Enter the VIN in Elsa and proceed to the “Campaign/Action” screen.

#### TIP

On the date of repair, print this screen and keep a copy with the repair order.

- Confirm the Campaign/Action is open <arrow 1>. If the status is closed, no further work is required.
- Note the Applicable Criteria ID <arrow 2> for use in determining the correct work to be done and corresponding parts associated.
- **All Safety Recalls MUST be completed before starting this Campaign.**

**Proceed to Section B**

## Section B – High-voltage Battery Removal from Vehicle

### DANGER

#### High-voltage can cause fatal injury

- The voltage levels in the high-voltage system constitute a safety hazard. Danger of severe or fatal injuries from electric shock.
- Persons with life-sustaining or other electronic medical devices in or on their body must not perform any work on the high-voltage system. Such medical devices include internal analgesic pumps, implanted defibrillators, pacemakers, insulin pumps and hearing aids.
- **An Audi high-voltage technician (HVT) or an Audi high-voltage expert (HVE) must de-energize and re-energize the high-voltage system.**

### CAUTION

#### Risk of damaging the high-voltage cables.

Incorrect handling can damage the insulation of the high-voltage cables or high-voltage connectors.

### NOTE

- Removing the high-voltage battery can be performed by a High-voltage Trained (HVT) technician.
- The High-voltage Expert (HVE) must be informed if the system cannot be de-energized.
- If the system cannot be de-energized, do not continue with work.

#### De-energize high-voltage system:

- Connect 12V battery charger.
- Start the ODIS program and perform a vehicle scan using “Diagnosis” Operating mode.
- Perform the following Guided Functions test plans in the following order.
  - “8C – Classification Hybrid battery unit”
  - “008C\_Isolationswiderstand\_HV\_Batterie\_messen\_93D2”
  - Record the results of the insulation test.

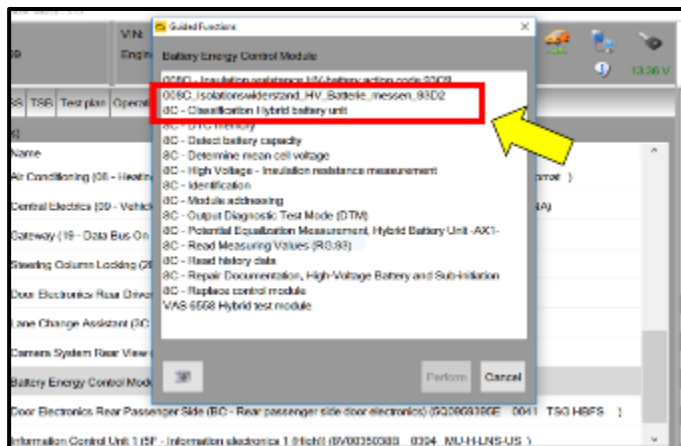

### CAUTION

The high-voltage expert must be informed if the system cannot be de-energized.



**NOTE**

The “008C\_Isolationswiderstand\_HV\_Batterie\_messen\_93D2” test plan will guide the repair in its entirety. Pay attention to the on-screen instructions. The “Function descriptions” within the test plan also provide useful information.

- Follow the test plan on-screen prompts.

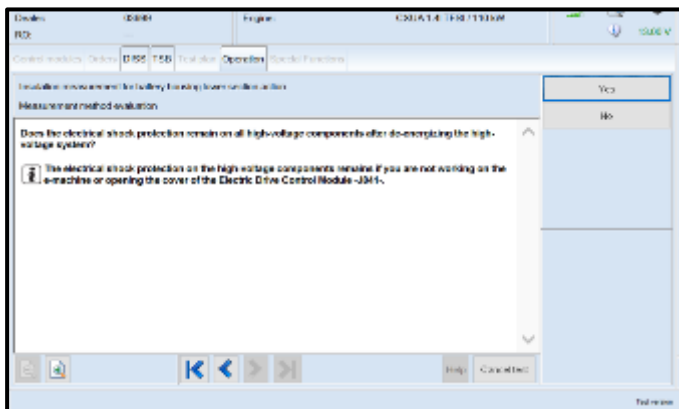

**Test plan text:** Does the electrical shock protection *remain* on all high-voltage components after de-energizing the high-voltage system?

**i** The electrical shock protection on the high-voltage components remains if you are not working on the e-machine or opening the cover of the Electric Drive Control Module -J841-.

**NOTE**



**Pay close attention when the 008C\_Isolationswiderstand\_HV\_Batterie\_messen\_93D2 de-energization test plan step asks about shock protection.**

This step refers to the shock protection installed on the e-machine or the Electric Drive Control Module -J841- prior to removing the battery. It does not refer to disassembling the high-voltage battery. Disassembling the high-voltage battery will be performed while wearing PPE.

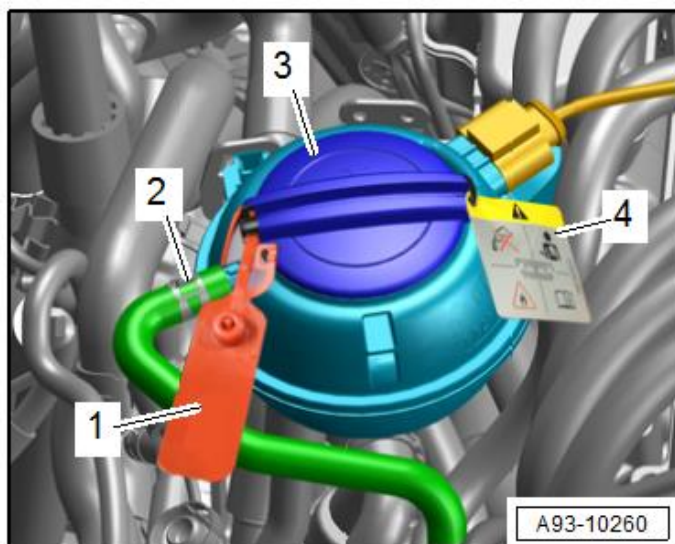

**Open coolant reservoir filler cap:**

**CAUTION**

**Risk of scalding due to hot steam and hot coolant.**

- The coolant system is under pressure when the engine is warm.
- Cover the coolant bottle cap with a cloth and then open it slowly to release the pressure.
- Cut anti-tamper seal <1>.
- Open filler cap <3>.



### Soak muffler nuts:

- Spray nuts <arrows> with a commercially available penetrating oil.

#### ! NOTE

Extreme care must be taken when removing the muffler nuts.

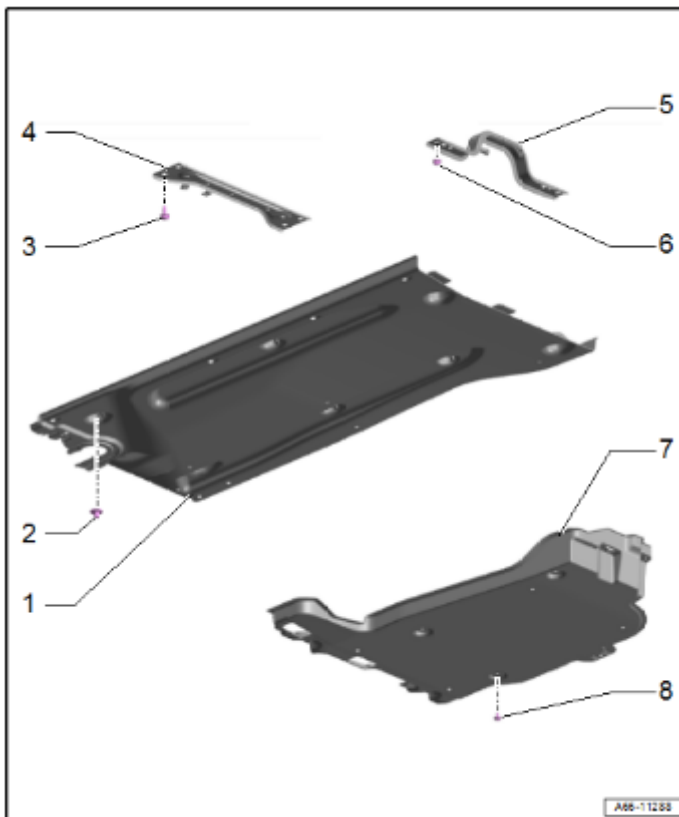

### Remove underbody trim panels and rear wheels:

- Support and remove center underbody panels <1>.
  - The lower rear of the front fender liners will also have to be loosened.
- Support and remove rear underbody panels <7>.
- Remove braces <4> and <5>.
- Remove both rear wheels.

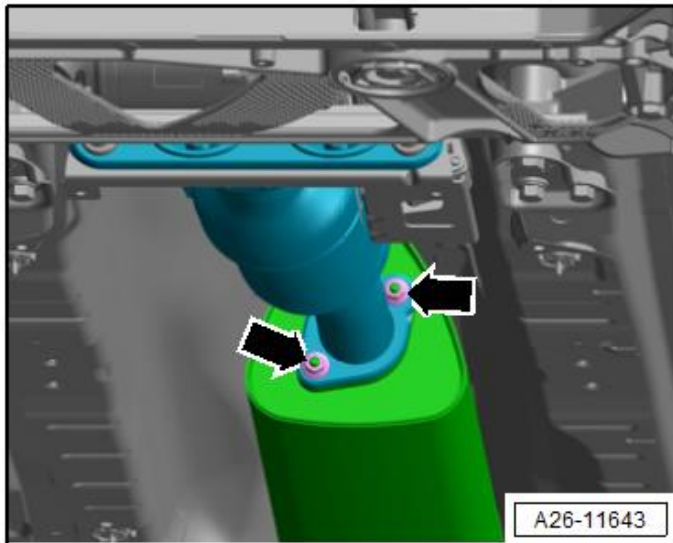

### Remove exhaust system:

- Remove nuts <arrows>.



### ! NOTE

If the muffler studs break, the studs can be replaced instead of replacing the entire muffler.

- Use a center punch in the exact center of the broken stud.
- Drill out the stud using a 3.5 mm drill bit first, then a 5.0 mm drill bit and finally a 6.8 mm drill bit.
- Then tap the hole using a M8 x 1.25 mm tap.
- Install stud(s) part number WHT.002.622
- U.S. Dealers: Contact Audi Warranty for claiming instructions.
- Canadian Dealers: Create an Audi Technical Assistance ticket and obtain campaign authorization for consequential damage.

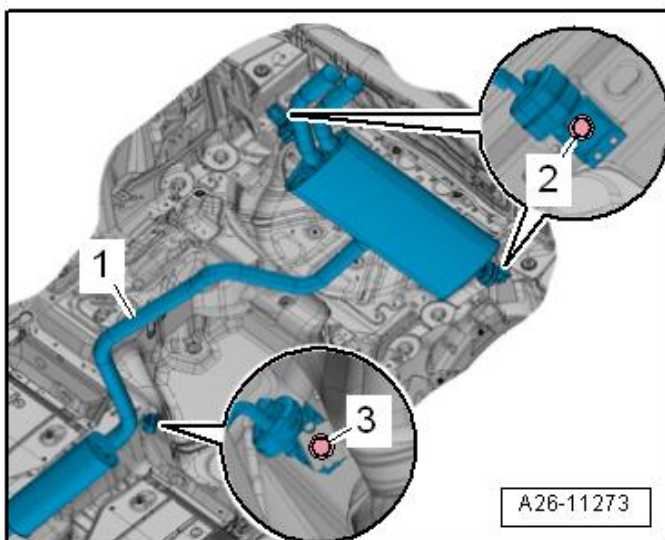

- Remove the left and right bolts <2>.
- Remove the bolt <3> and remove the exhaust system <1>.

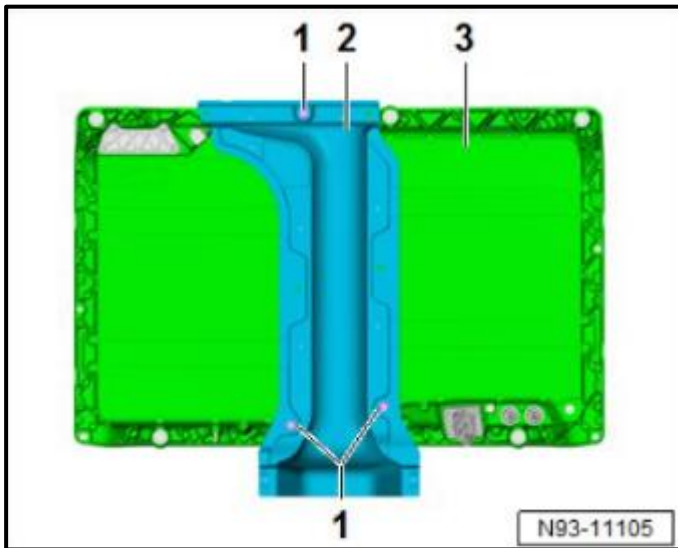

### Remove heat shield from battery:

- Remove bolts <1> from high-voltage battery <3>.
- Remove heat shield <2>.

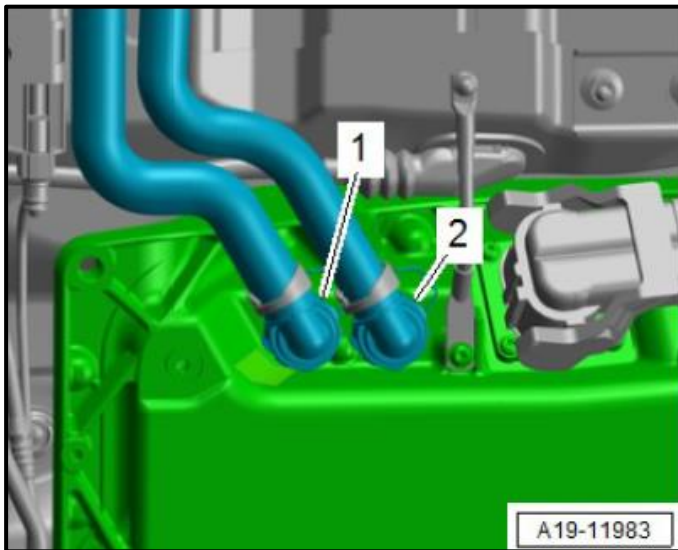

### Remove coolant hoses:

**⚠ CAUTION**

The high-voltage battery can become extremely hot. This can cause injuries. Take care not to burn your hands.

- Lift retaining clips <1> and <2>.
- Detach coolant hoses and let coolant drain from the high-voltage battery.
- Seal coolant hoses with -VAS691005/2-.

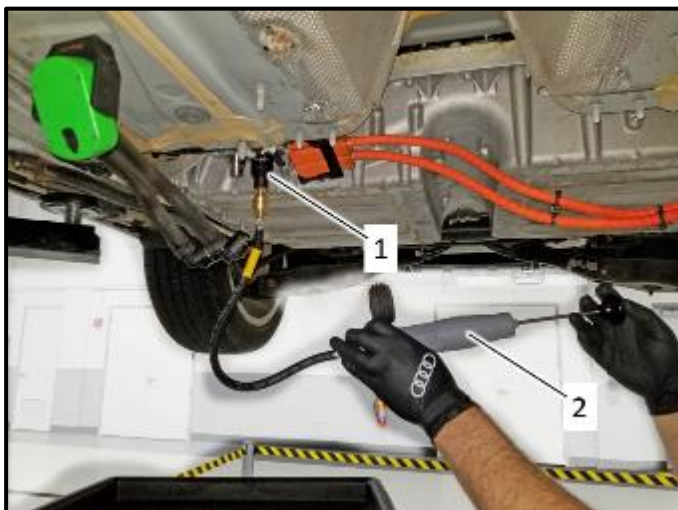

### Extract coolant from high-voltage battery coolant pipes:

- Connect coolant system tester adapter -VAS691005/4- <1> to a coolant hose connection on the high-voltage battery.
- Connect cooling system tester -VAG1274B- <2> to adapter <1>.
- Pump out all coolant from the high-voltage battery coolant pipes.

**ⓘ NOTE**

- Extracting all coolant from the coolant lines at this step prevents the risk of coolant leaking into the high-voltage battery housing during this repair.
- DO NOT use compressed air to force out coolant. Damage to the coolant pipes could occur.

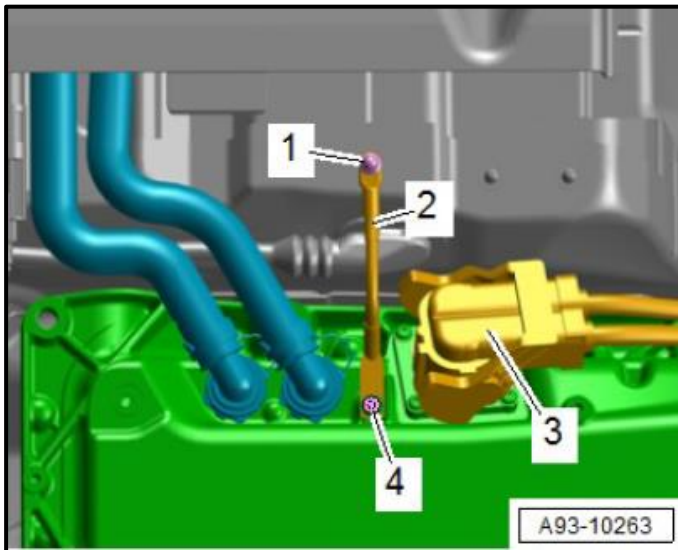

#### Prepare high-voltage battery for removal:

- Remove nut <1>.
- Remove bolt <4>.
- Remove potential equalization line <2>.
- Unplug electrical connector <3> and move clear.

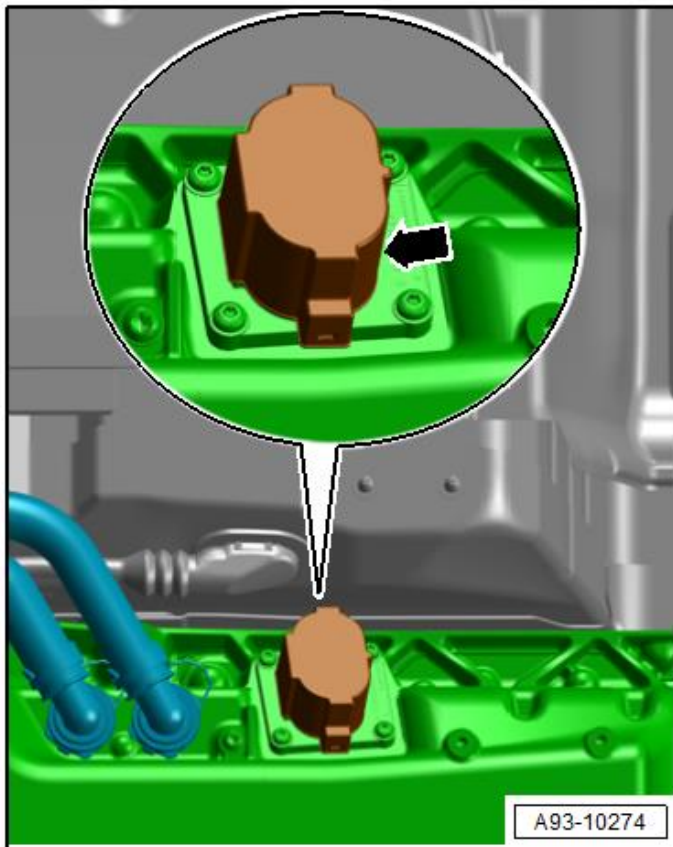

#### Prepare high-voltage battery for removal (cont.):

- Place the Transportation Protection Cap for DC Connector 12E.971.883 <arrow> on the connection for the high-voltage cable.

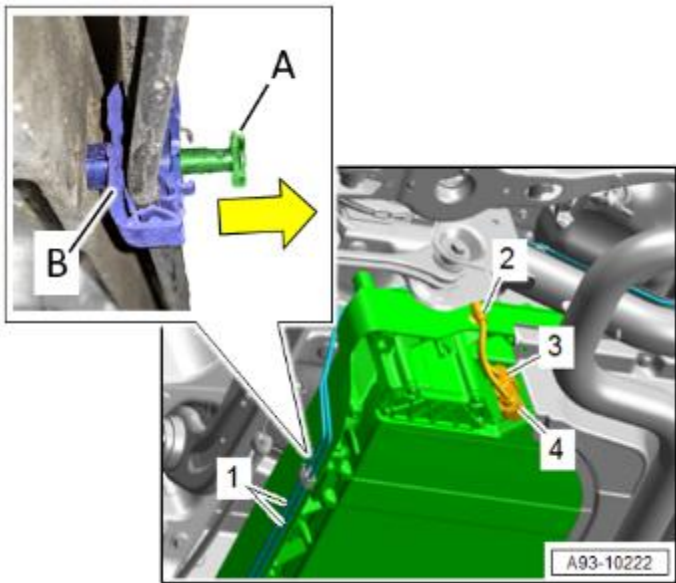

#### Prepare high-voltage battery for removal (cont.):

- Unplug electrical connector <3>.
- Move brake lines <1> clear.
  - Carefully pry out pin <A> from clip <B>.
  - Remove clip <B> from high-voltage battery.
  - Brake lines remain in clip <B>.
- Move electrical wiring harness <2> clear.

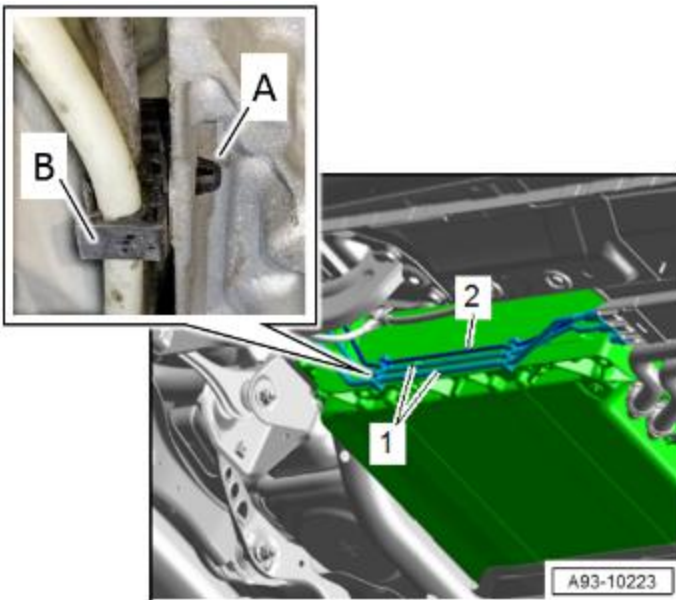

#### Prepare high-voltage battery for removal (cont.):

- Free up fuel lines <1>.
  - Unlock securing tabs <A> and remove fuel line clips <B> from high-voltage battery.
  - Remove fuel lines from clips <B>.
- Ignore item <2>.

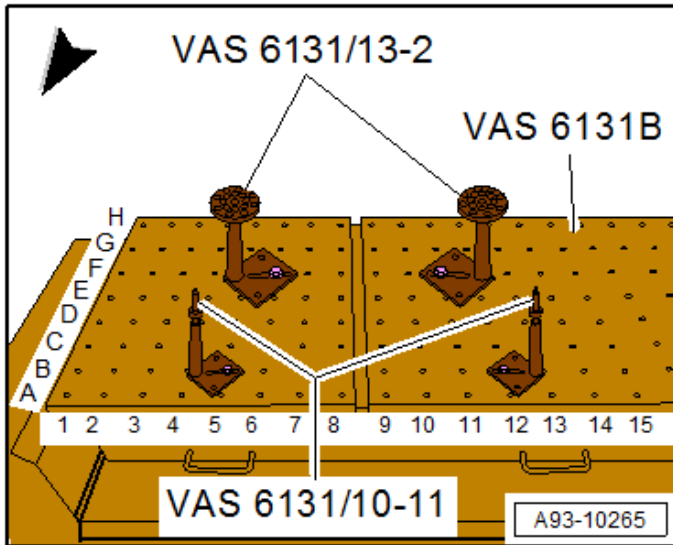

**Prepare scissor lift table:**

- Equip the -VAS6131B- with -VAS6131/10- and -VAS6131/13- as follows:

Table Coordinates	Supports from -VAS6131/10- and -VAS6131/13-			
B5	/10-1	/10-2	/10-5	/10-9
F6	/10-1	/10-2	/10-5	/13-2
B12	/10-1	/10-2	/10-5	/10-9
F11	/10-1	/10-2	/10-5	/13-2

- Secure the mounting elements to the scissor lift table by hand.
- Position the scissor lift table horizontally and verify it is level using the bubble gauge.

- Position the scissor lift table sideways under the vehicle (at a right angle to direction of travel).
- Make sure the threaded spindles are completely screwed in.
- Move the -VAS6131B- far enough upward until the mounting elements are positioned just under the high-voltage battery.
- Rotate all of the mounting element spindles upward until all the mounting pins come in contact with the mounting points.
- Tighten the mounting element base plates to scissor lift table to 20 Nm.





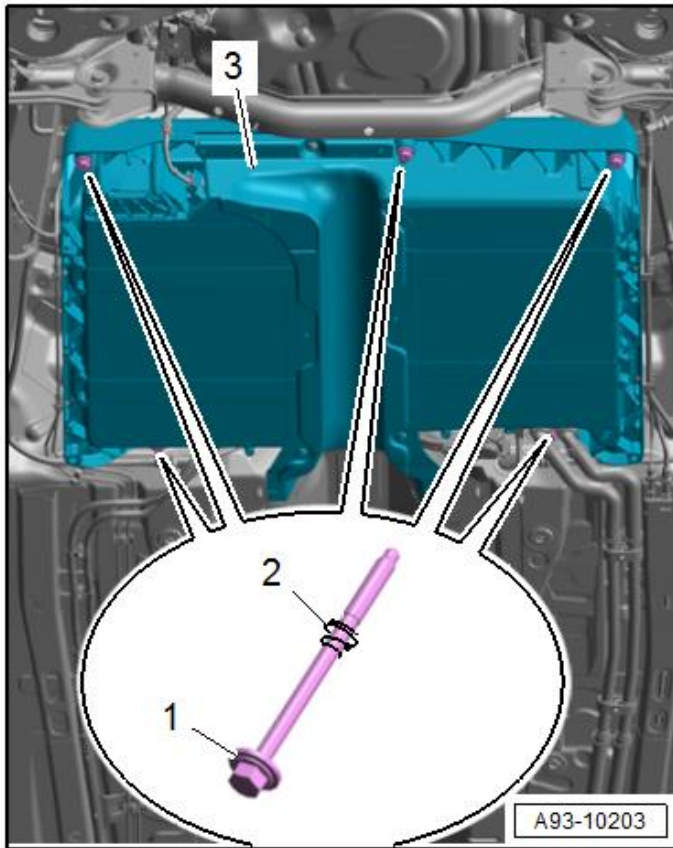

### Remove high-voltage battery from the vehicle:

- Remove the bolts <1>.
- The bolts have a fastener <2> so that they cannot fall out.

### **⚠ CAUTION**

#### **There Is a Risk of Damaging Lines and Hoses by Lowering the High-Voltage Battery.**

- Make sure all connections between the high-voltage battery and the body have been disconnected.
- Carefully guide the high-voltage battery out of the body when lowering.

- Lower the high-voltage battery <3> using the scissor lift table.

### **i TIP**

The high-voltage battery can be removed from the -VAS6131B- with the -VAS6100- without having to change the position of the scissor lift table.

- Move the scissor lift table with high-voltage battery to the cordoned off work area.

### **i TIP**

Mark the position of the scissor lift table wheels with tape or chalk to make installation of the battery easier.



### Proceed to Section C.

## Section C – High-voltage Battery Inspection Overview and Documentation

### DANGER

#### High-voltage can cause fatal injury.

- Danger of severe or fatal injuries from electric shock.
- Wear clothing approved for working with electric arcs.
- Wear an insulated helmet with a protective mask.
- Wear protective gloves.
- Wear safety shoes.
- The high-voltage system must be de-energized by a suitably qualified person.

### NOTE

- The high-voltage battery inspection must be done before AND after the high-voltage battery module group is removed from the battery housing.
- Removal of the battery housing (top section) and battery module group is outlined in Section D.

### **Examples of evidence of moisture, corrosion and green discoloration in the high-voltage battery:**

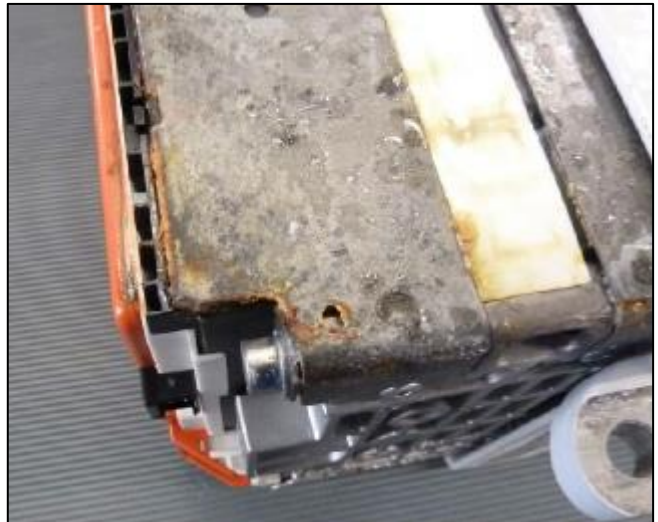
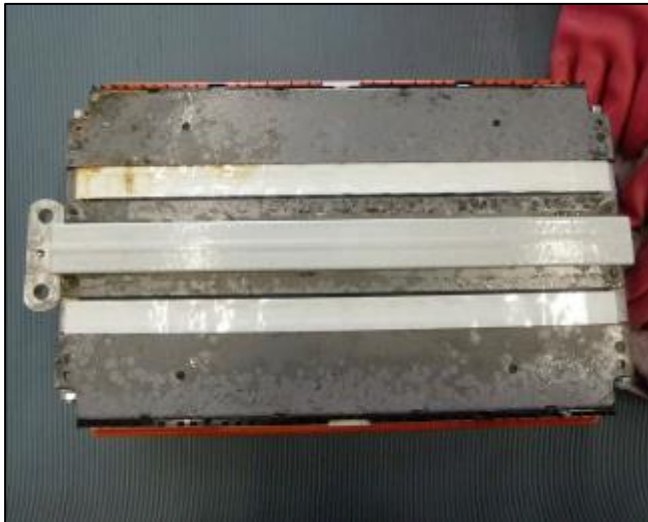



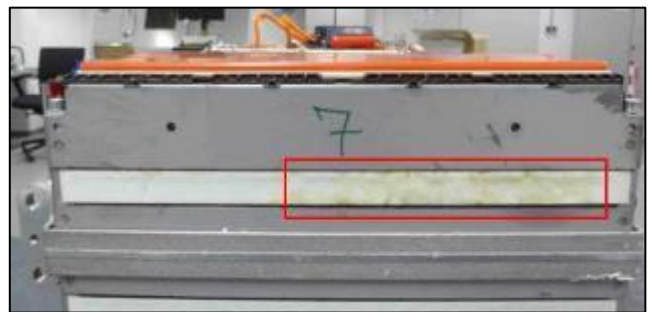

## Documentation Requirements

### NOTE

If there are no signs of water, moisture or corrosion, photos must still be uploaded to “doc-it” for documentation purposed. If the technician does not have access to “doc-it”, they must supply the photos to their warranty administrator to upload.

High-voltage battery leak test results:

Document results on repair order.

Are there signs of water, moisture or corrosion inside the battery?





NO:	Take clear photos of all six sides of the battery module group and the bottom section of the lower battery housing and upload photos to “doc-it”.	
	Take a clear photo of the low voltage connection inside the battery housing (bottom section) and upload photo to “doc-it”.	
	Take a clear photo of the entire battery housing (lower section) and upload photo to “doc-it”.	
	High-voltage battery housing requires replacement (outlined in Section D).	
	YES:	Audi Technical Assistance WEB contact must be created.
		Take clear photos of the component and a close up photo of the corrosion and attach to the TAC case.
Take clear photos of all six sides of the high-voltage battery module group and the battery housing and attach to the TAC case.		
If moisture can only be felt, e.g. black mat in the bottom section of the battery housing is wet/moist, state: “moisture can only be felt, picture not capturing condition” in TAC case.		
Document leak test results in TAC case.		
Document insulation test results in TAC case.		

## Photograph Requirements

### NOTE

The follow are examples of how the required photographs should appear.

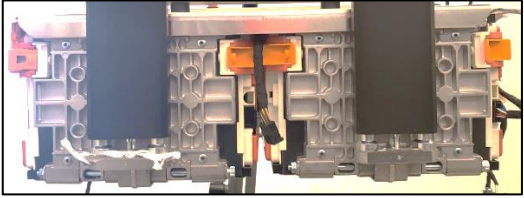
### Photos for EVERY case:

<p>Top and bottom of battery module group.</p>		
<p>All four sides of the battery module group.</p>		
<p>Battery housing (lower section). Low voltage connector.</p>		

### Additional photos if corrosion or moisture is found:

<p>Wide shot of the component.  Close up of the condition (moisture or corrosion).</p>		
--	---	--

## Section D – Opening High-voltage Battery Housing

### DANGER

#### High-voltage can cause fatal injury.

- Danger of severe or fatal injuries from electric shock.
- Wear clothing approved for working with electric arcs (PPE).
- Wear an insulated helmet with a protective mask.
- Wear protective gloves.
- Wear safety shoes.
- The high-voltage system must be de-energized by a suitably qualified person.

### WARNING

The work must be performed by a high-voltage expert (HVE) who has received additional training.

### CAUTION

- Risk to health due to toxic dust and liquids.
- Never perform work on high-voltage batteries in which a short circuit has occurred.
- The high-voltage battery can become extremely hot. This can cause injuries. Take care not to burn your hands. Wear protective gloves.

### CAUTION

#### Separating battery housing:

- Work must be performed by high-voltage expert (HVE).
- A second qualified person is required for all work on a high-voltage battery that has been opened.
- The second person must not actively work on the high-voltage battery, he/she is present as a safeguard in the event of an accident.

- This section is made up of five sub-sections:
  1. Performing High-voltage Battery Leak Test
  2. Removing High-voltage Battery Module Group.
  3. Preparing New Battery Housing.
  4. Reinstalling Battery Module Group into Battery Housing.
  5. Sealing Battery Housing

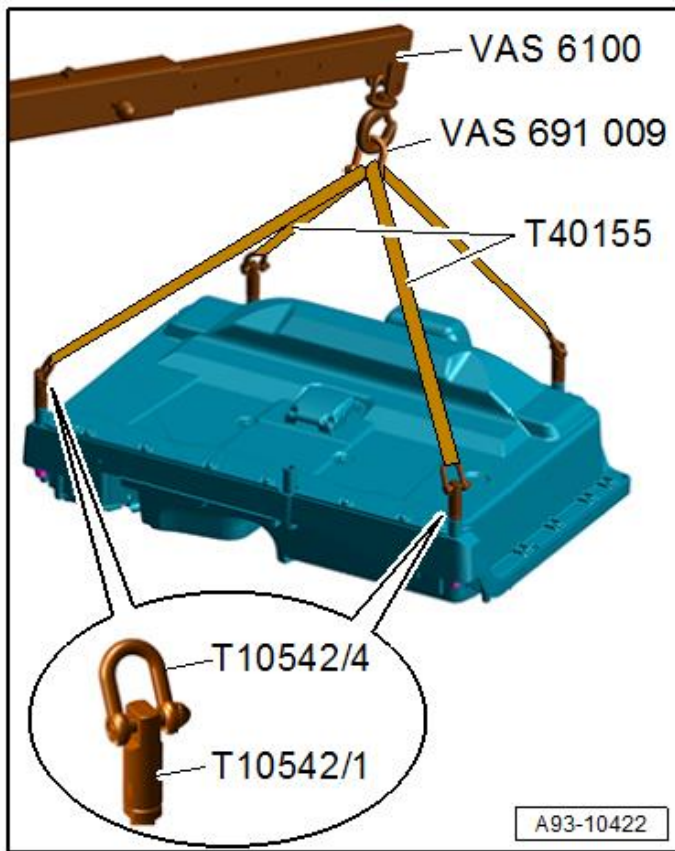

**Moving high-voltage battery to work station (if necessary):**

- If the high-voltage battery is moved to a work bench from the scissor lift table to perform the work on the high-voltage battery:
  - The bench must be covered by insulating mat -VAS6762/44-.
  - Install -T10542/1- and -T10542/4- on the high-voltage battery as shown, align the shackle to the center of the battery and tighten the original bolts to 40 Nm.
  - Secure one -T40155- to both of the left -T10542/4- and one -T40155- to both right -T10542/4- as shown.
  - Bind both -T40155- together over the high-voltage battery using shackle -VAS691009-.



**If corrosion is found (as outlined in Section B) on the high-voltage battery at any time during removal:**

- Refer to the "Documentation Requirements" above in Section C.
- Proceed to Section E.



## Subsection 1 – Performing High-voltage Battery Leak Test

### Perform HV battery leak test:

- Perform tests in the following order:
  1. Perform self-test on Leak Tester -VAS6911/3A-1-.
    - a. See Appendix C.
  2. Perform high-voltage battery acclimatization (pressure equalization) test.
    - a. See Appendix D.
  3. Perform high-voltage battery pressure test.
    - a. See Appendix E.
- If the pressure test fails, record the results of the pressure test.

## Subsection 2 – Removing High-voltage Battery Module Group

- The work must be performed within the cordoned off area.
- The work requires a second technician AND BOTH technicians MUST be wearing their Personal Protective Equipment.
- The second technician must not actively work on the high-voltage battery. They are present as a safeguard in the event of an accident.
- The fasteners must be removed with tools from the High Voltage Tool Set -VAS6762- and -VAS691003-.

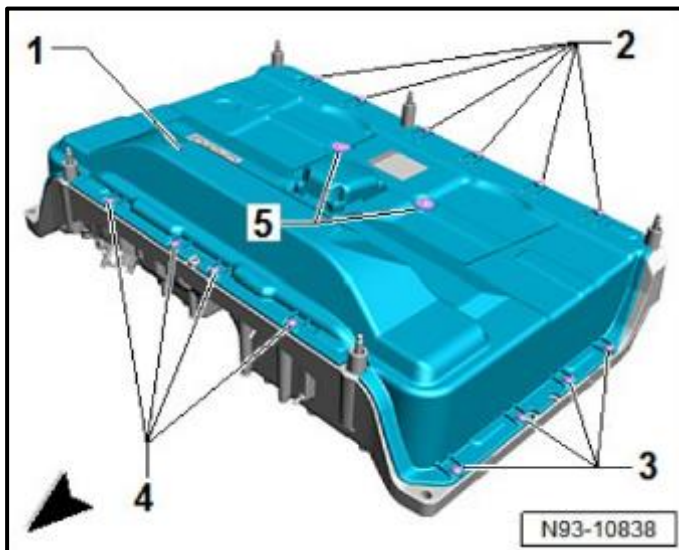

### Remove high-voltage battery housing bolts:

- Remove bolts <2 through 5> on battery housing (top section) <1>.

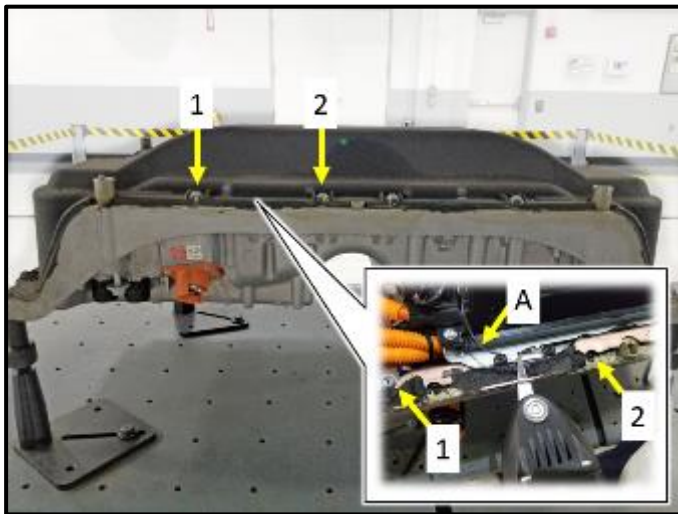

**CAUTION**

- When cutting between bolts <1> and <2>, it is possible that the cutting tool can go in too far and make contact with the SX6 ground wire <A>.
- Use extreme care when cutting between bolts <1> and <2> so the wire <A> is not damaged.

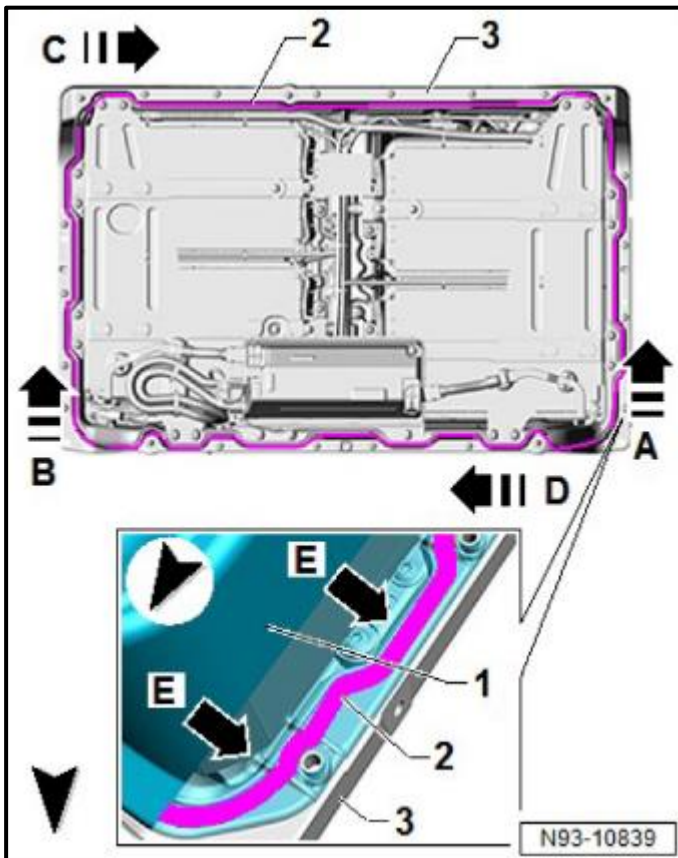

**Separate battery housing sections using -VAG1561A:**

- Fit blade (27 mm) -VAS6900/1- to electric cutter -VAG1561A-.
- Adjust speed on electric cutter -VAG1561A- to 4.
- Cut open bonded seam <2> between battery housing (top section) <1> and battery housing (bottom section) <3> in direction of <arrow A>.
- Cut open bonded seam <2> in direction of arrow <B>.
- Cut open bonded seam <2> in direction of arrow <C>.
- Cut open bonded seam <2> in direction of arrow <D>.
- Detach battery housing (top section) <1> from battery housing (bottom section) <3>.
- If necessary, use lever -VAS6900/6- to carefully pry battery housing (top section) <1> off battery housing (bottom section) <3> and apply removal wedge -3409-.

**NOTE**

- Hold electric cutter -VAG1561A- at bottom and with both hands.
- Guide electric cutter -VAG1561A- along edge <arrows E> of battery housing (bottom section) <3>.



### Perform insulation measurement:

- Use test plan “008C\_Isolationswiderstand\_HV\_Batterie\_messen\_93D2”.
- Record insulation measurement results.

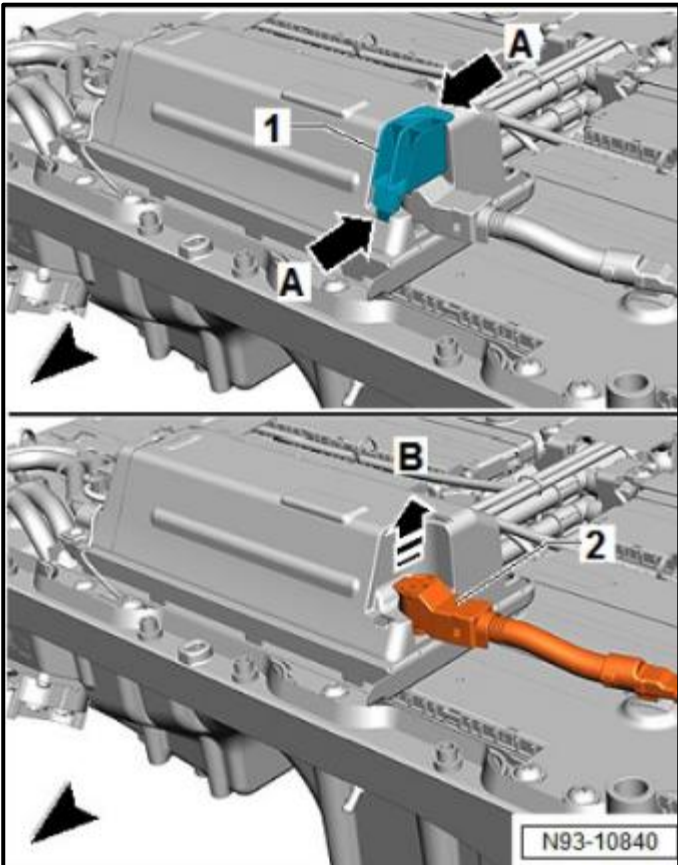

### Disconnect cables to SX6:

#### NOTE

It can be helpful to make sketches or take photographs of the electrical wiring and the installation position of electrical connectors and cable ties. This helps to ensure that components are re-installed in their original positions.

- Release cover <1> <arrows A> and detach.
- Disconnect connecting cable 9 for battery module -P34- <2> in direction of <arrow B> from connection on switching unit for high-voltage battery -SX6- and fit end caps -VAS6762/48- on removed cable.

#### CAUTION

Use extreme care when removing covers <1>. The locking tabs can be easily damaged during removal.

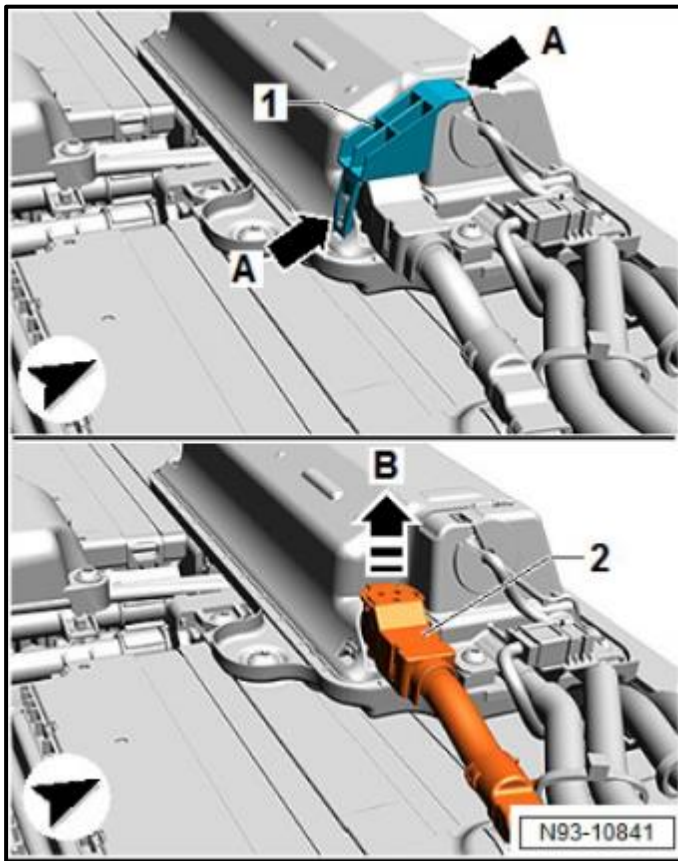

**CAUTION**

Use extreme care when removing covers <1>. The locking tabs can be easily damaged during removal.

- Release cover <1> <arrows A> and detach.
- Disconnect connecting cable 1 for battery module -P26- <2> in direction of <arrow B> from connection on switching unit for high-voltage battery -SX6- and fit end caps -VAS6762/48- on removed cable.



- End caps -VAS6762/48- <arrows> must be fitted over the cable ends before continuing.

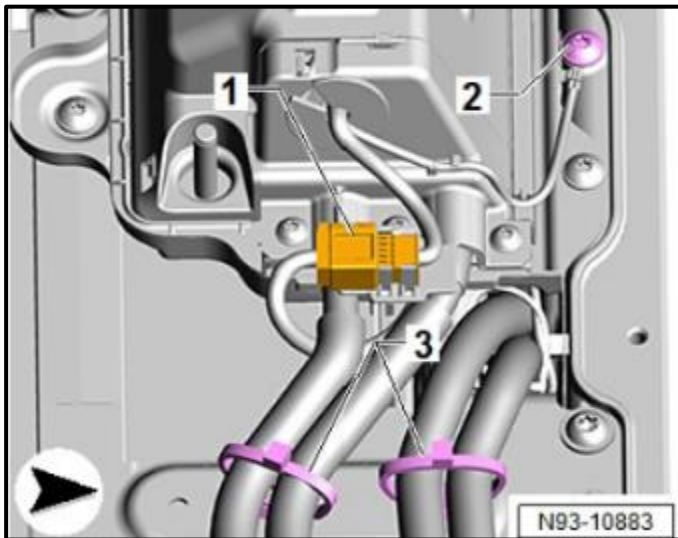

#### Disconnect connectors for SX6:

- Release and unplug electrical connector <1>.
- Remove bolt <2>.
- Cut tie wraps <3>.

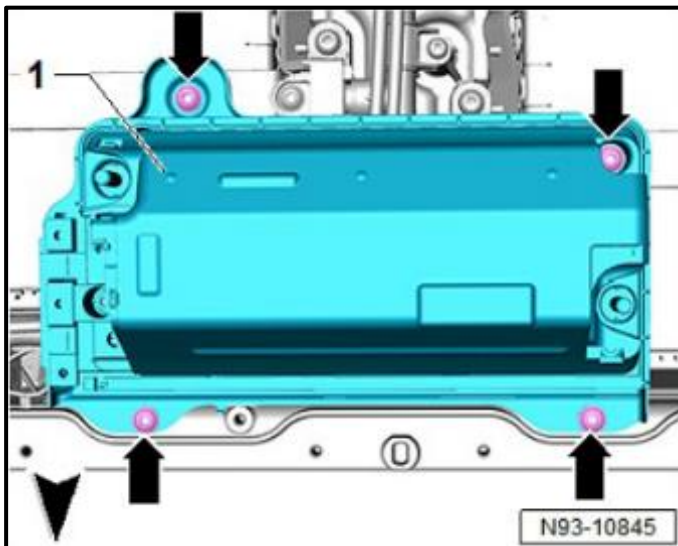

#### Remove SX6:

- Remove bolts <arrows>.

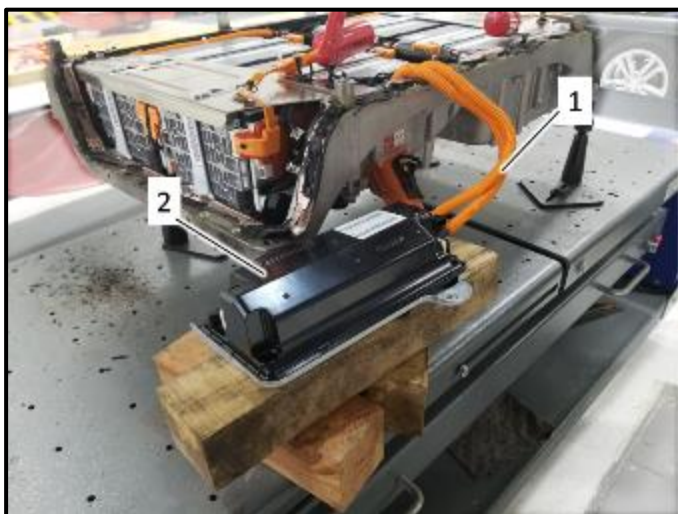

#### Support -SX6-:

- Leave high-voltage cables <1> connected to -SX6- <2>.
- Support -SX6- <2> so the high-voltage cables <1> are not under stress.

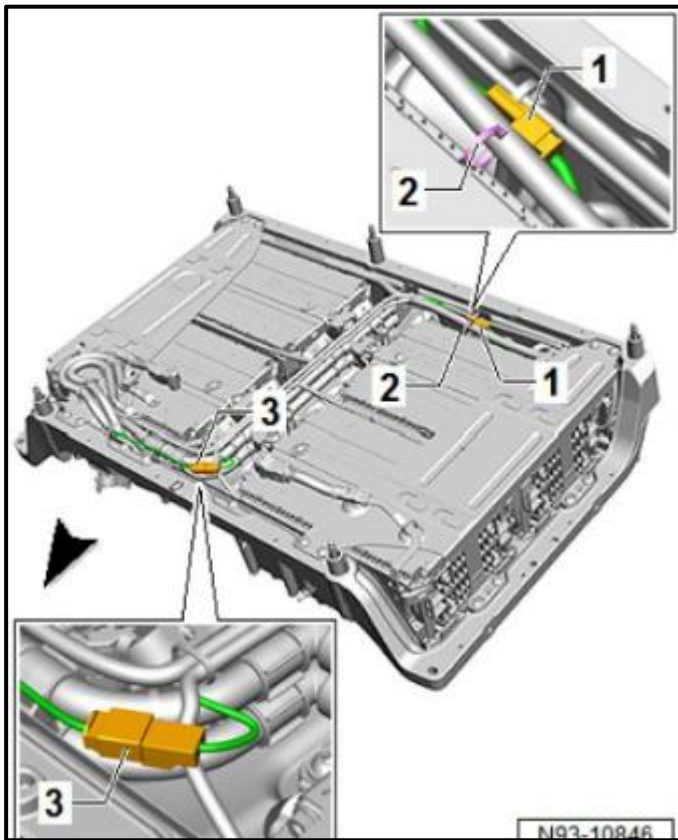

#### Disconnect connectors and pilot wire:

- Release and unplug electrical connector <1>.
- Release and unplug electrical connector <3> for pilot wire.
- Unclip wiring harnesses from battery housing (lower section).

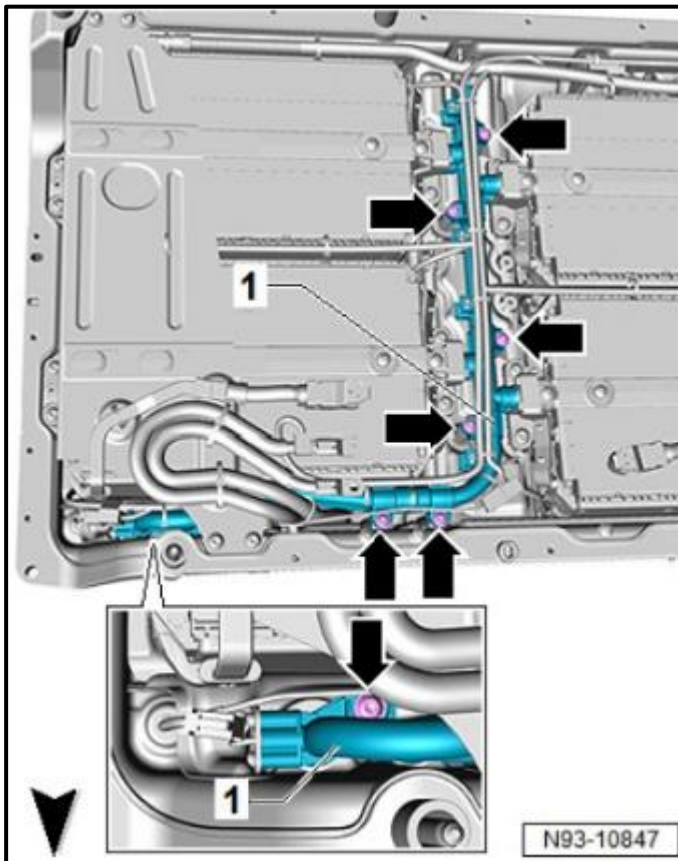

#### Remove coolant pipe bolts:

- Loosen all seven bolts <arrows> for coolant pipes <1>.

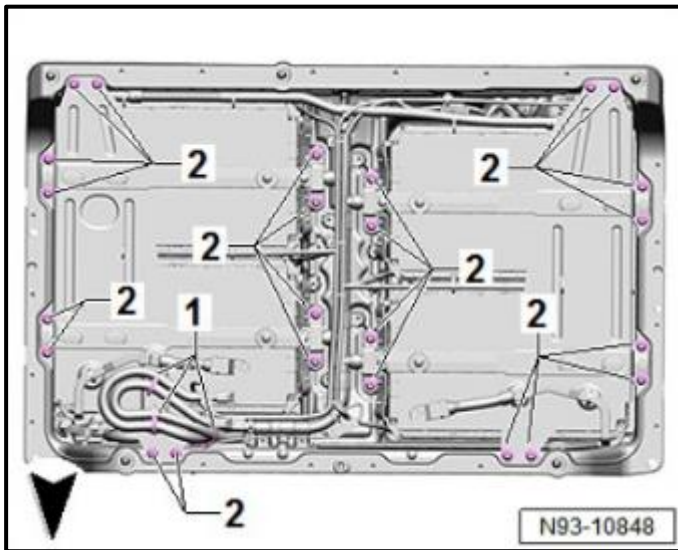

### Remove high-voltage battery bolts:

- Loosen coolant pipes <1> from connections on battery housing (bottom section).
- Remove bolts <2>.
- After removing bolts <2>, remove any metal shavings using a wet/dry vacuum cleaner with plastic nozzle.
- Remove excess adhesive away from mounting areas for high-voltage battery.

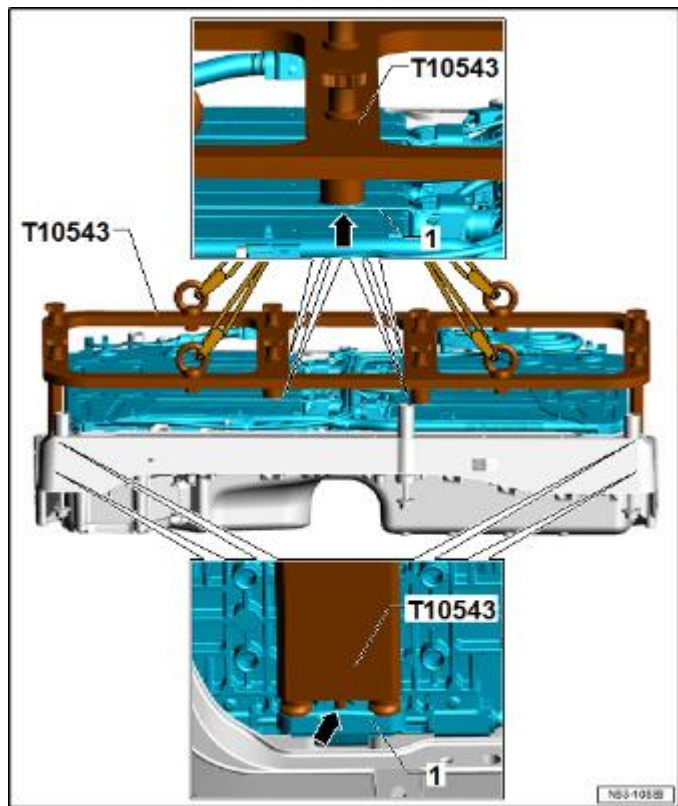

### Attach support tool -T10543-:

- Remove adhesive residue from mountings for lifting device.
- Secure support tool -T10543- to shop crane -VAS6100- using shackle -VAS691009- and retaining straps -T40155-.
- Position support tool -T10543- with shop crane -VAS6100- centrally above battery module assembly <1> so that battery module assembly <1> remains level when it is lifted out of battery housing (bottom section).
- Secure support tool -T10543- to mounting points <arrow> on battery module assembly <1>.

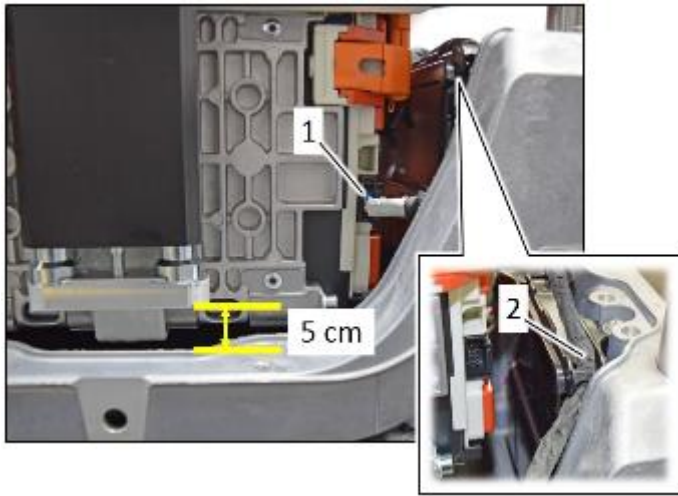

### Free up wire for Battery Regulation Control Module -J840-:

- Lift battery module assembly <1> via lifting device by approx. 5 cm using shop crane -VAS6100-.
- Disconnect connector <1>.
- Unhook the wire <2> on the bracket for the -J840-.

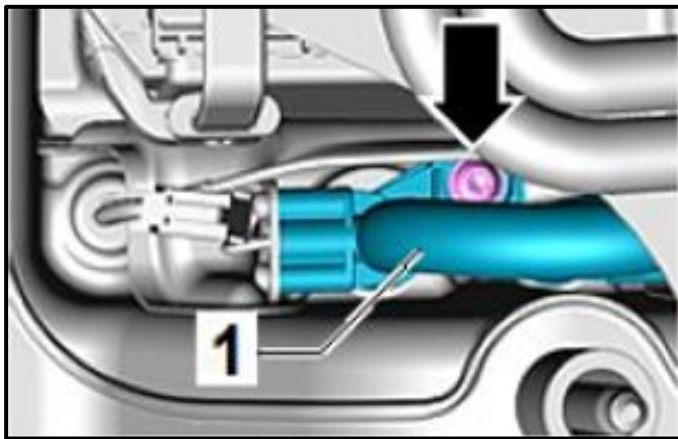

- Ensure the bolt <arrow> is removed.
- Carefully pry the coolant pipe <1> out of the coolant connection on the battery housing (lower section).





**NOTE**



The requirement to take clear photos of all six sides of the high-voltage battery is best done at this point.

**Lift battery out of battery housing:**

- Carefully lift the battery module group <1> out of the battery housing lower section using the Shop Crane -VAS6100-.
- Place the battery module group on the insulation mat from the High-Voltage Tool Set -VAS6762-.
- Carry out a visual check of high-voltage components and high-voltage wiring.
- Perform visual check of bolted connections for modules.
- Document routing of wiring from battery regulation control unit -J840-.
- Guide electrical wire out of guide for battery regulation control unit -J840-.
- Lever coolant pipes out of coolant connection on battery housing (bottom section).
- Battery housing (bottom section) can be moved out of cordoned-off area.

**DANGER**

High-voltage battery module group must remain in the cordoned off area.

**NOTE**

Photo shows work being done on a bench. Work is similar when battery housing (lower section) is attached on the scissor lift table.

**Inspect high-voltage battery for corrosion:**

- Refer to the “Documentation Requirements” above in Section C.
- If there is no evidence of moisture or corrosion:
  - High-voltage battery housing requires replacement.
  - Proceed to Subsection 3.
- If evidence of moisture or corrosion is found:
  - High-voltage battery requires replacement.
  - Proceed to Section E.

## Subsection 3 – Preparing New Battery Housing

- This work can be done outside the cordoned off area.
- PPE is not required.
- Standard hand tools can be used.

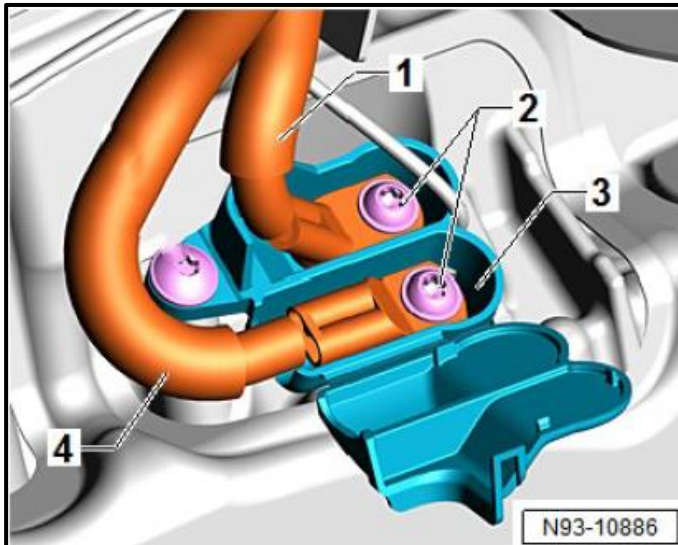

### Remove SX6 from old battery housing bottom section:

- Open cover on housing <3>.
- Note the wire installation positions.
- Remove bolts <2> and remove high-voltage wires <1> and <4>.

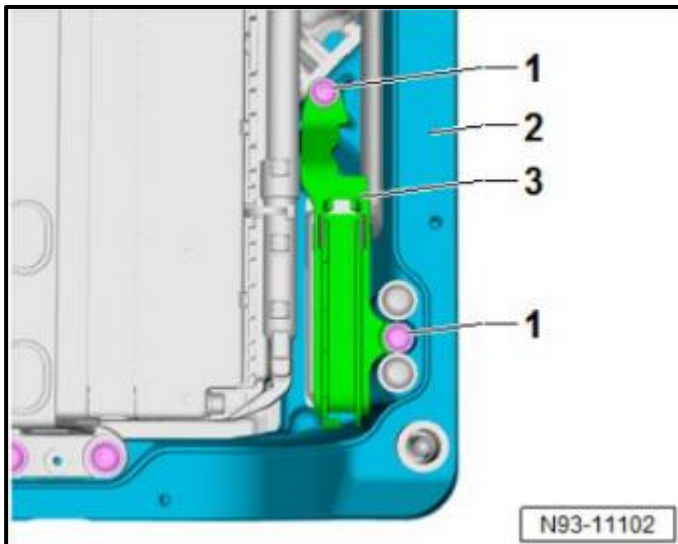

### Remove J840 from old battery housing bottom section:

- Remove bolts <1> from bracket for battery regulation control unit -J840- <3>.
- Remove bracket for battery regulation control unit -J840- <3> from battery housing (bottom section) <2>.

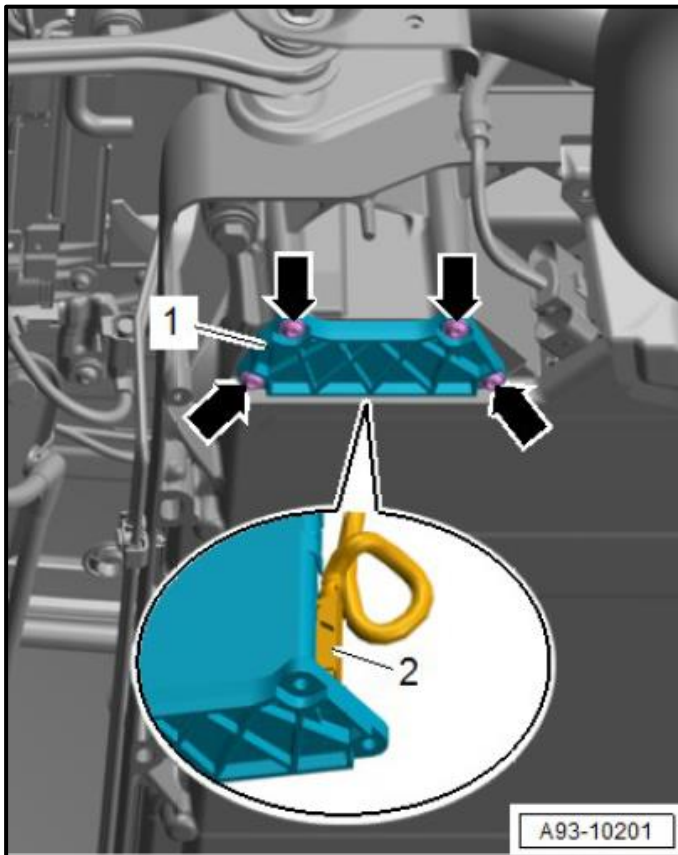

- Remove bolts <arrows>.
- Unplug electrical connector <2>.
- Remove battery regulation control unit -J840- <1>.
- Remove seal from battery regulation control unit -J840-.



- Mask off all warning signs and labels in area of adhesive bead with painters tape on the new battery housing (bottom section).
- Mask off holes for brake lines and fuel lines in area of adhesive bead with painters tape on the new battery housing (bottom section).
- Mask off fluid connection in battery housing (bottom section).

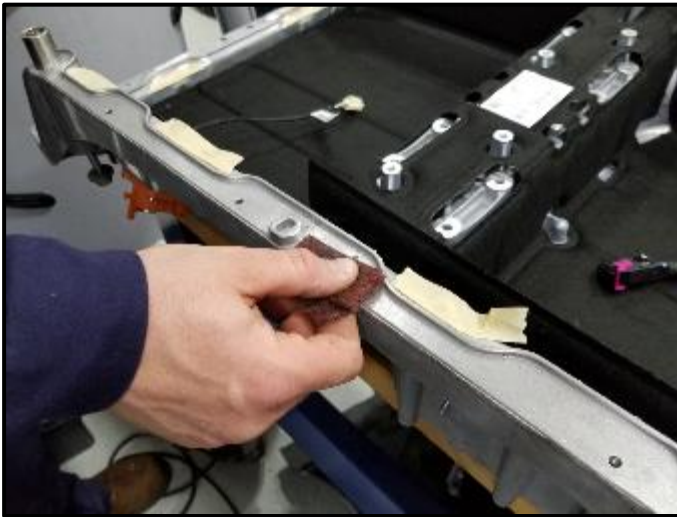

**Apply “scratch coat” to new battery housing (bottom section):**

- Use a non-woven scuff pad (3M “Scotch Brite 07447, for example) to manually remove any residue from battery housing (bottom section).
- Do not use power tools or materials that will sand or grind away the housing material.



**Temporarily fit top section to bottom section with a few bolts:**

- Fix the two halves of the battery housing together with some bolts tightened by hand.
- Mark outlines of battery housing (top section) on battery housing (bottom section) using a pick or scribe.
- Separate the two halves of the battery housing.



**Vacuum debris:**

- Vacuum all dust and debris out of the battery housing (bottom section).

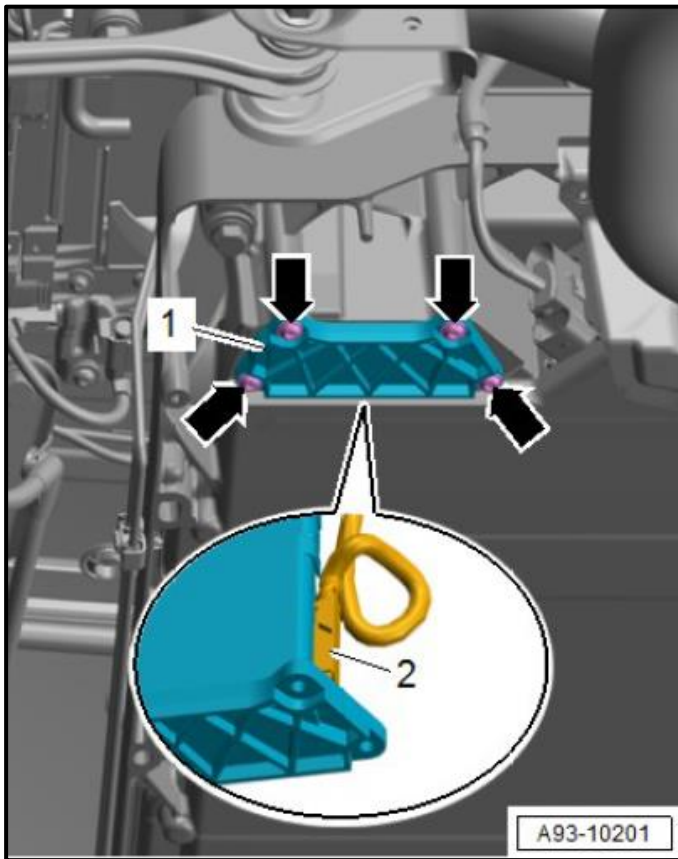

**Install J840:**

- Clean sealing flanges for J840.
- Install new gasket for J840.

Part Number	Part Description
5Q0.915.433	Gasket (from battery housing repair kit)

- Plug in electrical connector <2> with battery regulation control unit -J840-.
- Fit battery regulation control unit -J840- in battery housing (bottom section).
- Install new bolts <arrows> and torque to 8 Nm in diagonal sequence.

Part Number	Part Description
N 106.321.02	M6x25 bolt (from battery housing repair kit)

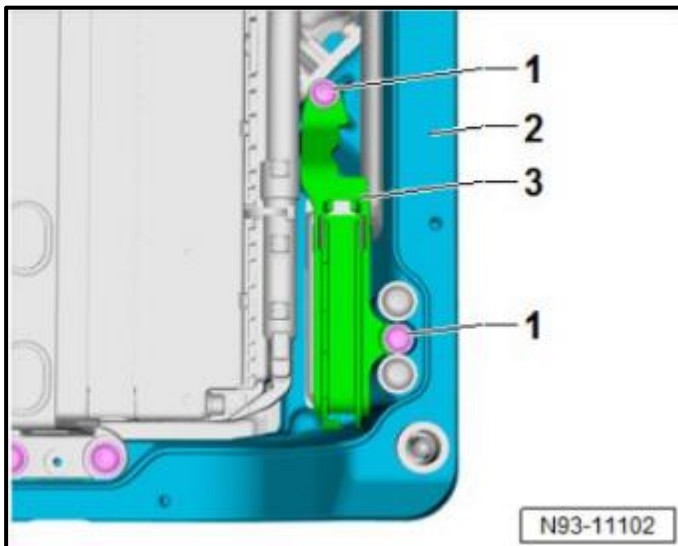

- Install bracket for battery regulation control unit -J840- <3> in battery housing (bottom section).
- Tighten bolts <1> for bracket for battery regulation control unit -J840- <3> to 10 Nm.

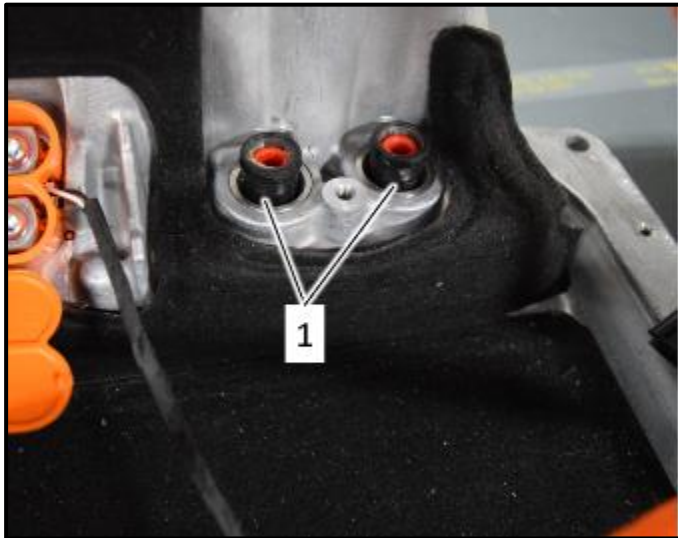

### Install coolant pipe connection in battery housing lower section:

- Insert new coolant pipe connections <1> in battery housing (bottom section) with lithium grease G 052.150.A2 (shop supply).

Part Number	Part Description
5Q0.915.373.B	Coolant pipe connecting piece

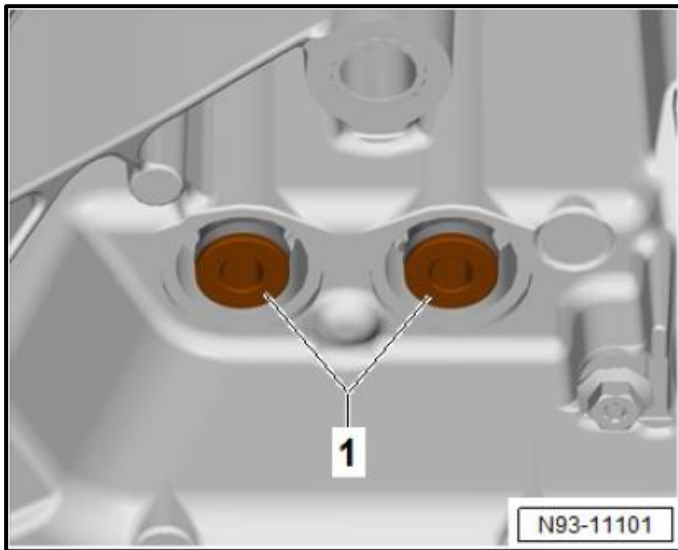

### Seal coolant connections:

- Insert pins -VAS691005/9- <1> in coolant connections on battery housing (bottom section).
- Seal coolant connections using sealing plugs -VAS691005/3-.

#### ! NOTE

Since the guide pins -VAS691005/9- are installed, the sealing plugs -VAS691005/3- will not lock into place.

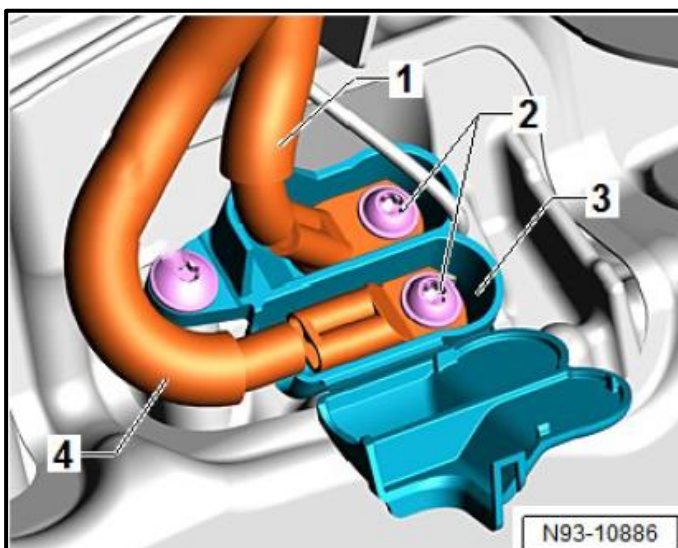

### Install high-voltage cables:

- Place high-voltage wires <1> and <4> in housing guide <3>.
- Install new bolts <2> and torque to 8 Nm.

Part Number	Part Description
5Q0.998.215.A	M6x16 bolts - silver (from battery housing repair kit)

#### i TIP

The bolts <2> secure the high-voltage cables to the terminals, which move independently of the cable housing guide.

- Close cover on housing <3>.
- Proceed to Subsection 4.

## Subsection 4 – Reinstalling Battery Module Group Into Battery Housing

- The work must be performed within the cordoned off area.
- The work requires a second technician AND BOTH technicians MUST be wearing their Personal Protective Equipment.
- The second technician must not actively work on the high-voltage battery. They are present as a safeguard in the event of an accident.
- The fasteners must be installed with tools from the High Voltage Tool Set -VAS6762- and -VAS691003-.



### Vacuum debris out of high-voltage battery:

- Use a wet/dry vacuum with a plastic nozzle and vacuum all debris and sealant residue from high-voltage battery.

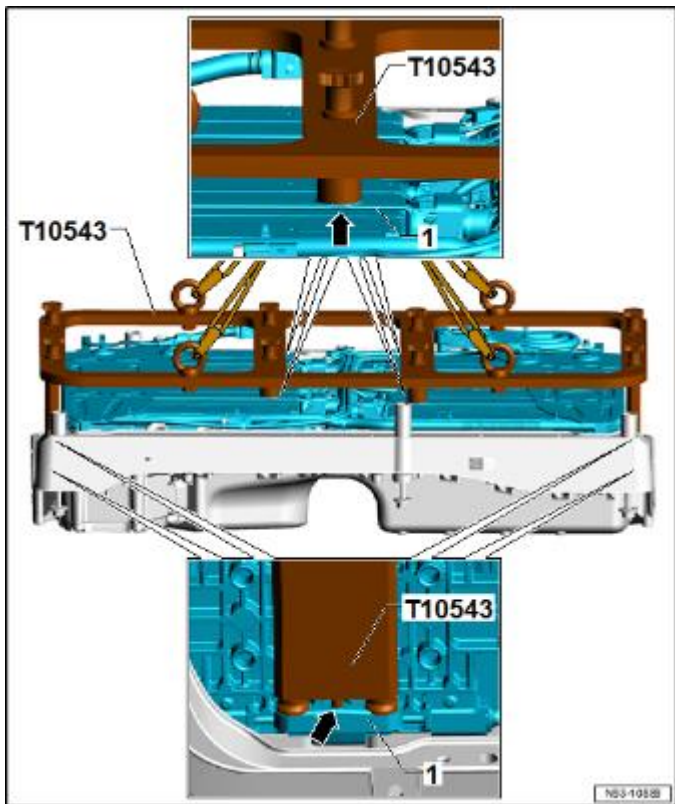

**Position HV battery:**

- Move new battery housing (bottom section) back to scissor lift table.
- Position battery module assembly above battery housing (bottom section) using workshop hoist -VAS6100- and support tool -T10543-.



**Lower HV battery module assembly into battery housing lower section:**

- Guide battery module assembly carefully into battery housing (bottom section), paying attention to electrical wiring and coolant pipes.



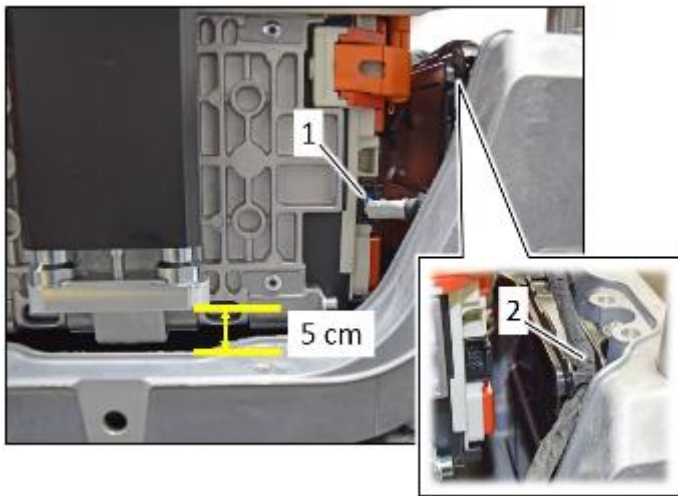

- Approx. 5 cm before battery module assembly reaches its final position in battery housing (bottom section):
  - Connect coolant pipes of battery module assembly to connections in battery housing (bottom section).
  - Guide cable <2> into bracket for - J840-.
  - Install connector <1>.
  - Lower battery module assembly to end position.

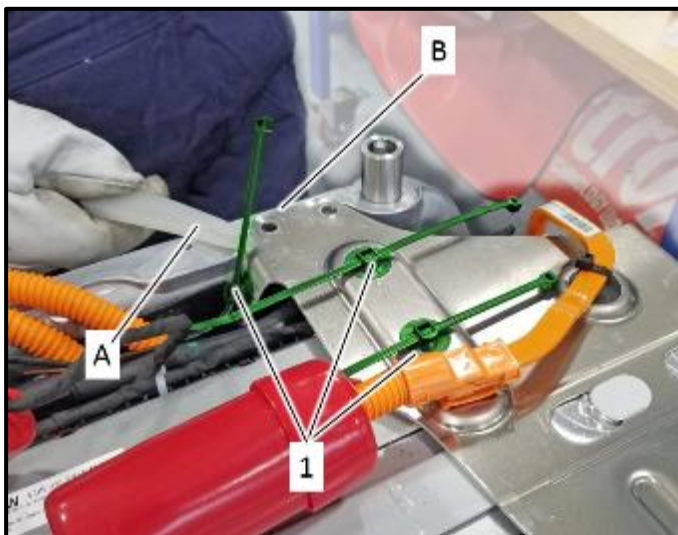

**Install cable ties:**

- Pre-install new cable ties <1>.

Part Number	Part Description
N 907.726.01	Cable tie

- When installing cable ties, the high-voltage battery support <B> will need to be pried up slightly with using the -3409- in order for the new locking tabs to fully engage.

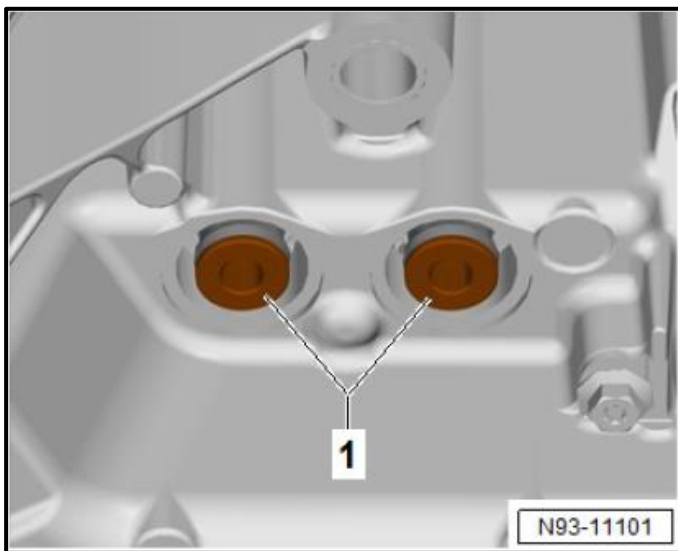

**Remove guides:**

- Remove guides -VAS691005/9- <1> from coolant connections on battery housing (bottom section).

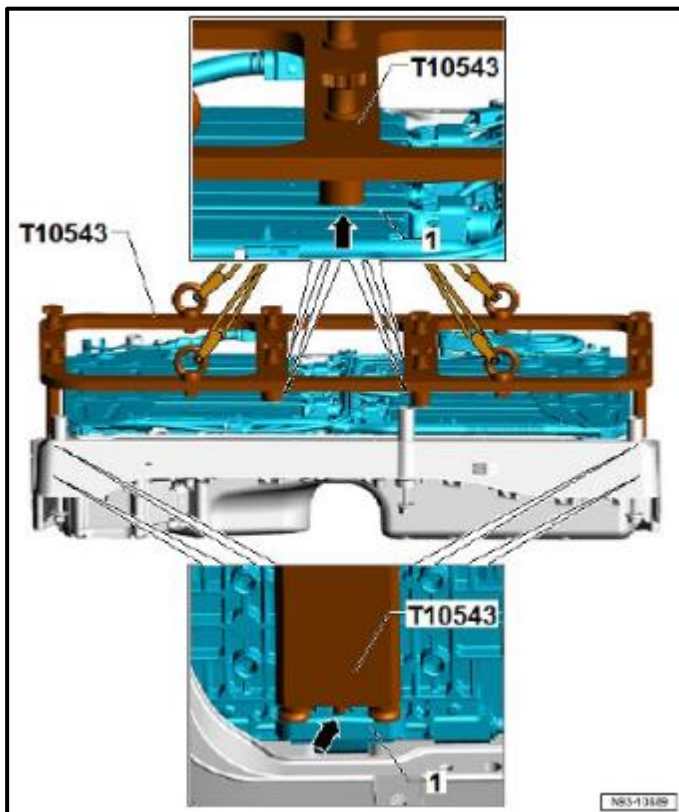

#### Disconnect support tool -T10543-:

- Loosen support tool -T10543- at mounting points <arrow> on battery module assembly <1>.
- Detach support tool -T10543- with the shackle -VAS691009-.
- Put support tool -T10543- down safely.

#### Carry out a visual check of high-voltage components and high-voltage wiring:

- Check high-voltage components and high-voltage wiring for external damage.
- Check insulation for high-voltage wires and potential equalization lines for damage.

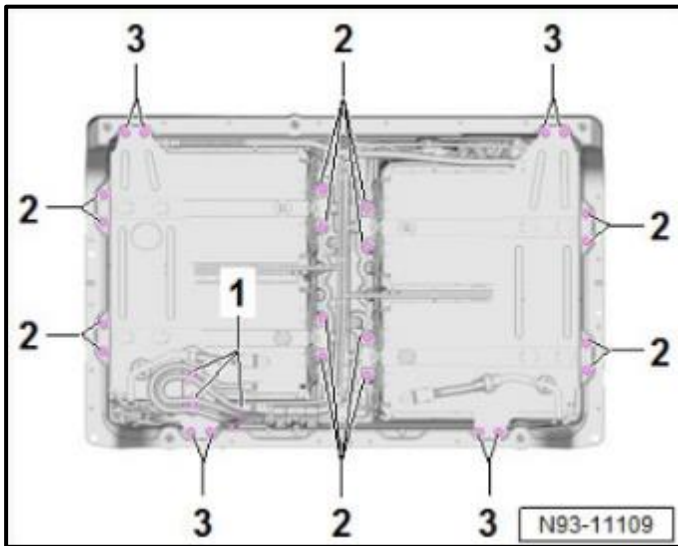

### Secure HV battery:

#### NOTE

- The new battery housing (bottom section) is supplied without pre-cut threads in the area of the bolted connection <2> for the battery module assembly and the cross member <3>.
- DO NOT pre-thread holes <2 and 3>.
- Install new bolts <2> and <3> using -VAS691003/19-

Part Number	Part Description
WHT.008.861	M8x30 Bolt (from battery housing repair kit)

- Observe the following bolt installation sequence:
  - Torque bolts <2> to 20 Nm.
  - Torque bolts <3> to 22 Nm.
  - Loosen bolts <2> and <3> by half a turn.
  - Torque bolts <2> to 20 Nm.
  - Torque bolts <3> to 22 Nm.

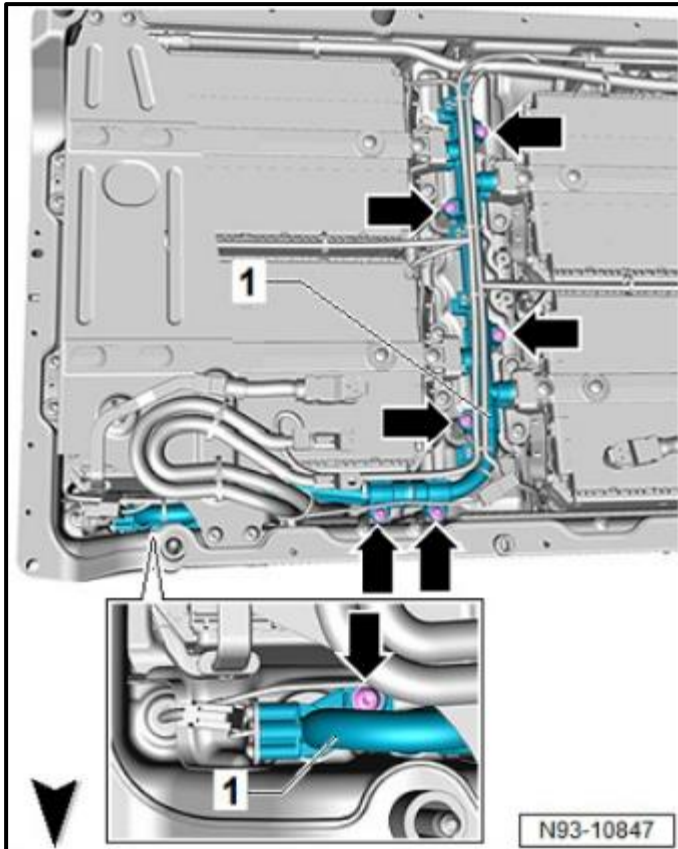

### Secure coolant pipes:

- Connect coolant pipes <1> to connections on battery housing (bottom section).
- Install bolts <arrows> and torque to 8 Nm.

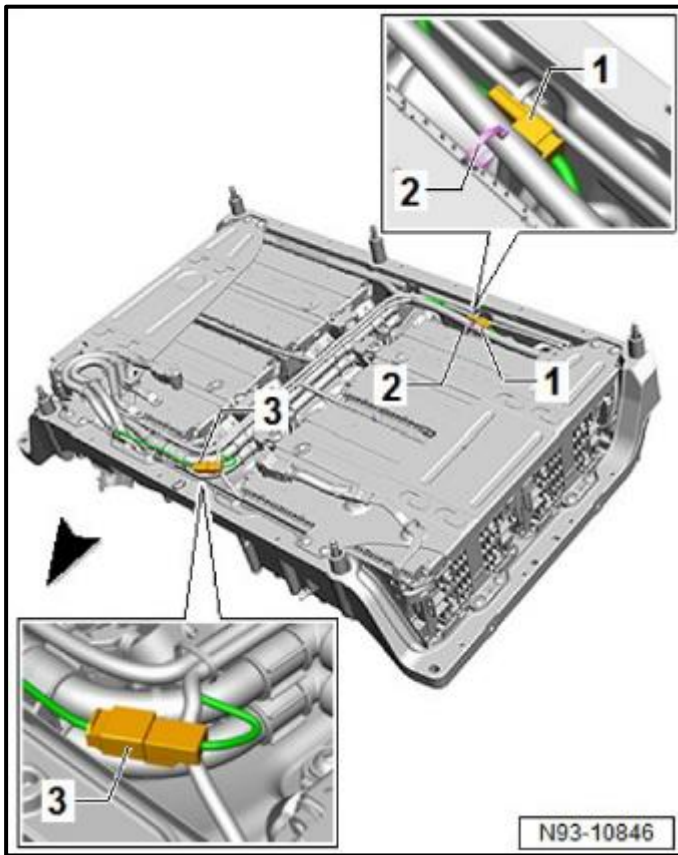

**Connect electrical connectors:**

- Secure electrical connector <1>.
- Plug in electrical connector <3> for pilot wire.

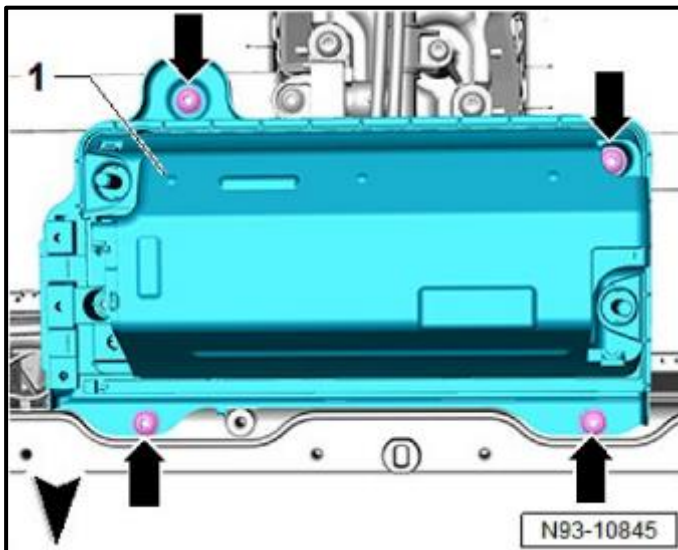

**Install SX6:**

- Clean threads.
- Install bolts <arrows> with commercially available locking fluid (medium strength) and torque to 8 Nm.

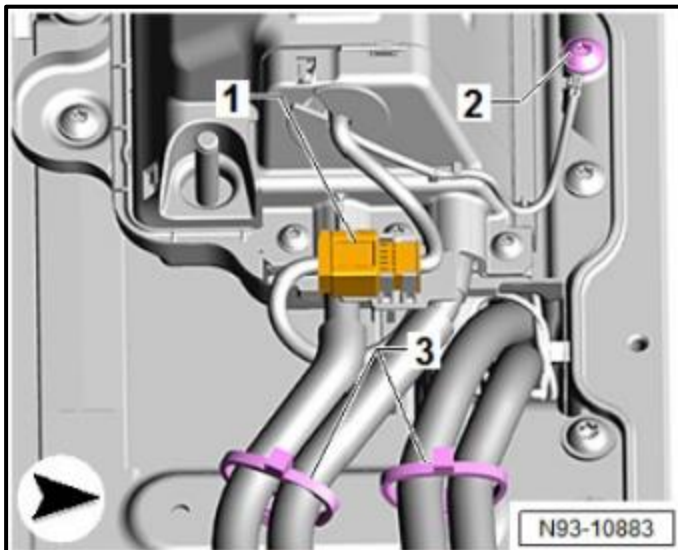

#### Install cable ties and connect electrical connector:

- Secure cable ties <3> around high-voltage cables.
- Connect and attach connector <1>.
- Clean threads for bolt <2>.
- Install bolt <2> with commercially available locking fluid (medium strength) and torque to 8 Nm.

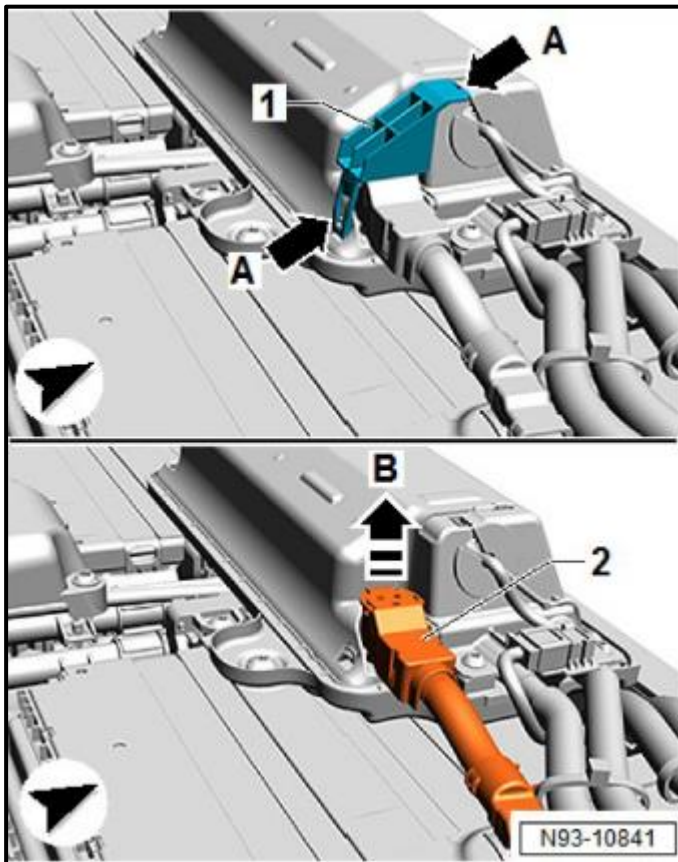

#### Connect HV cables:

- Remove end cap -VAS6762/48- <1> from connecting cable 1 for battery module -P26-.
- Connect connecting cable 1 for battery module -P26- <2> at switching unit for high-voltage battery -SX6-.
- Lock cover <1> <arrows A>.

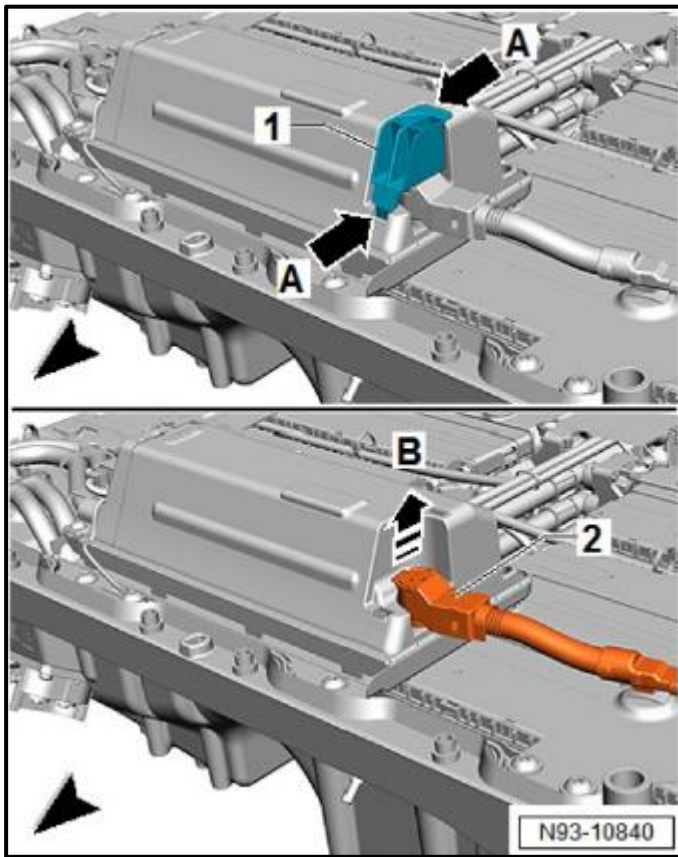

- Remove end cap -VAS6762/48- <1> from connecting cable 9 -P34-.
- Connect connecting cable 9 for battery module -P34- <2> at switching unit for high-voltage battery -SX6- in opposite direction of <arrow B>.
- Lock cover <1> <arrows A>.



#### Perform insulation measurement:

- Use test plan "008C\_Isolationswiderstand\_HV\_Batterie\_messen\_93D2".

#### Perform cooling system leak test:

- Perform cooling system tester self-test (see Appendix A).
- Perform high-voltage battery cooling system leak test (see Appendix B).
- Proceed to Subsection 5.

## Subsection 5 – Sealing Battery Housing

- The work must be performed within the cordoned off area.
- The work requires a second technician AND BOTH technicians MUST be wearing their Personal Protective Equipment.
- The second technician must not actively work on the high-voltage battery. They are present as a safeguard in the event of an accident.
- The fasteners must be installed with tools from the High Voltage Tool Set -VAS6762- and -VAS691003-.

### Bonding battery housing:

- Perform bonding procedure in one step.
- Do not interrupt the bonding procedure.
- Avoid taking breaks until the bonding procedure is complete.
- Bonding surfaces are sensitive to dust and grease. The adhesive will not be effective if there is any dust or grease.
- Bonding surface must be free of dirt and grease.



### Apply bonding agent to battery housing (bottom section):

- Clean battery housing (bottom section) with isopropyl alcohol and lint-free cloth thoroughly in area of adhesive bead.
- Allow cleaning solution to completely dry.
- Apply bonding agent along entire flange of battery housing (bottom section) and approx. 2 cm below edge of flange.
- Allow bonding agent to flash off until it is dry.

Part Number	Part Description
D 355.205.A2	Bonding agent

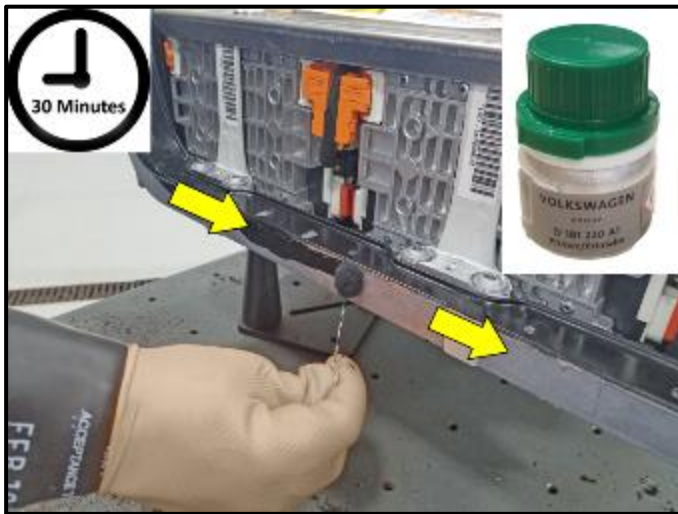

### Apply primer to battery housing (bottom section):

- Use applicator to apply primer for battery housing (bottom section) evenly and in one direction to flange on battery housing (bottom section) and approx. 2 cm over edge of flange; make sure there are no air bubbles.
- Allow primer to flash off for 30 minutes until it is dry.

Part Number	Part Description
D 181.220.A1	Primer

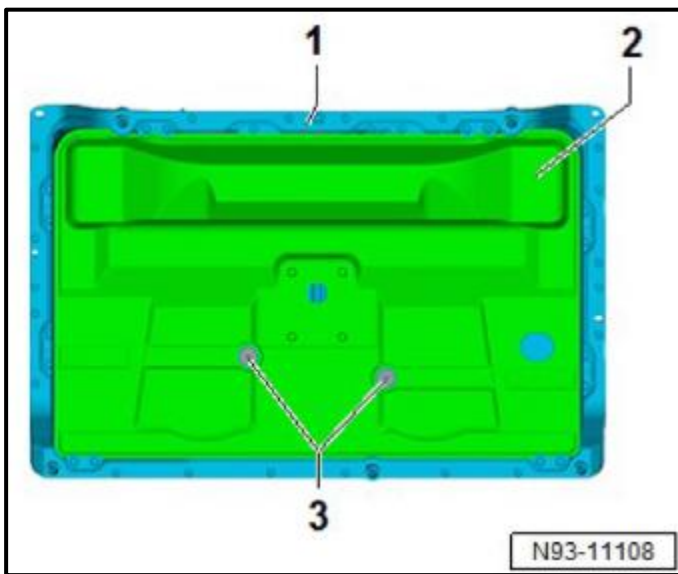

### Clean and prepare top section:

- Ensure that heat insulation mat <2> is securely seated in battery housing (top section) <1>.
- The sealing/bonding surface must not be covered by the heat insulation mat.
- Holes <3> must have sufficient clearance to heat insulation mat <2>.
- Rework heat insulation mat <2> with workshop equipment if necessary.
- Clean battery housing (top section) with isopropyl alcohol and lint-free cloth thoroughly in area of adhesive bead.
- Allow cleaner to completely dry.
- Use applicator to apply primer for battery housing (top section) evenly and in one direction around adhesive bead and approx. 5 mm over edge of flange on battery housing (top section); make sure there are no air bubbles.
- Allow primer to flash off for 30 minutes until it is dry.





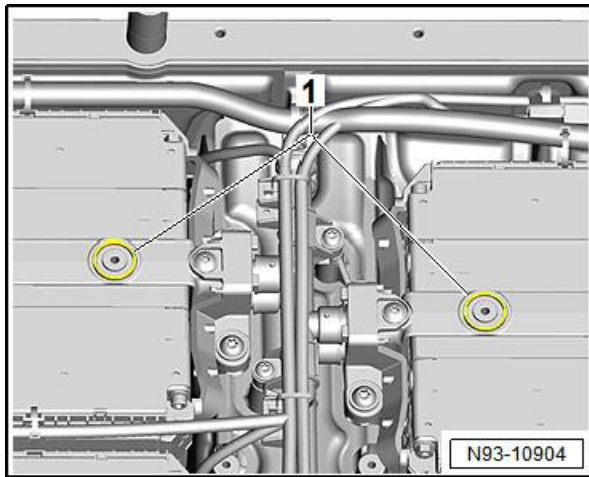

**Install seals:**

- Install new seals <1>.

Part Number	Part Description
N/A	Seals (from battery housing repair kit)



**Prepare pneumatic gun -VAS6648-:**

- Pneumatic gun -VAS6648- requires Hi-Flo Milton air coupler V-Style S-764 for 1/4" hoses OR V-Style S-766 for 3/8" hoses. (MCQ764).
- DO NOT change the fitting on pneumatic gun -VAS6648-.
- Install adhesive cartridge into pneumatic gun -VAS6648-.

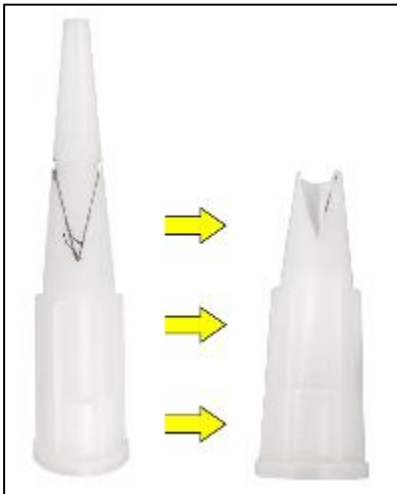

Part Number	Part Description
D 190.000.M2	Adhesive

- Cut the nozzle provided down to the marked position 3.
- Set desired pressure on pneumatic gun, -VAS6648-.
  - Apply a short test bead on cardboard to determine the desired operating pressure.



**NOTE**

The battery housing (top section) must be fitted within 20 minutes, otherwise the battery housing sections will not bond properly.

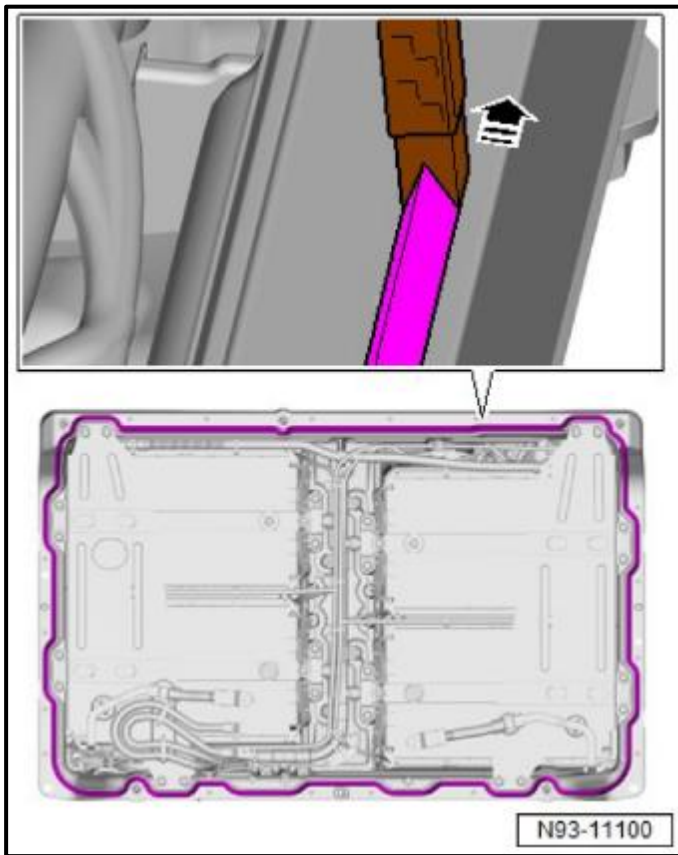

### Apply first bead:

#### NOTE

- When applying the first adhesive bead, use the outline of the battery housing (top section) on the battery housing (bottom section) for orientation.
- The adhesive bead can pass over bolt holes.
- Two cartridges of adhesive contain enough material for two parallel beads.
- The pneumatic gun -VAS6648- must remain perpendicular to the battery housing (bottom section) flange when applying the adhesive bead.
- Start applying adhesive bead on long side of battery housing (bottom section).
- Apply adhesive bead around entire circumference at a right angle to battery housing (bottom section) so that ridge is vertical.
- Apply adhesive bead so that start and end of bead overlap.

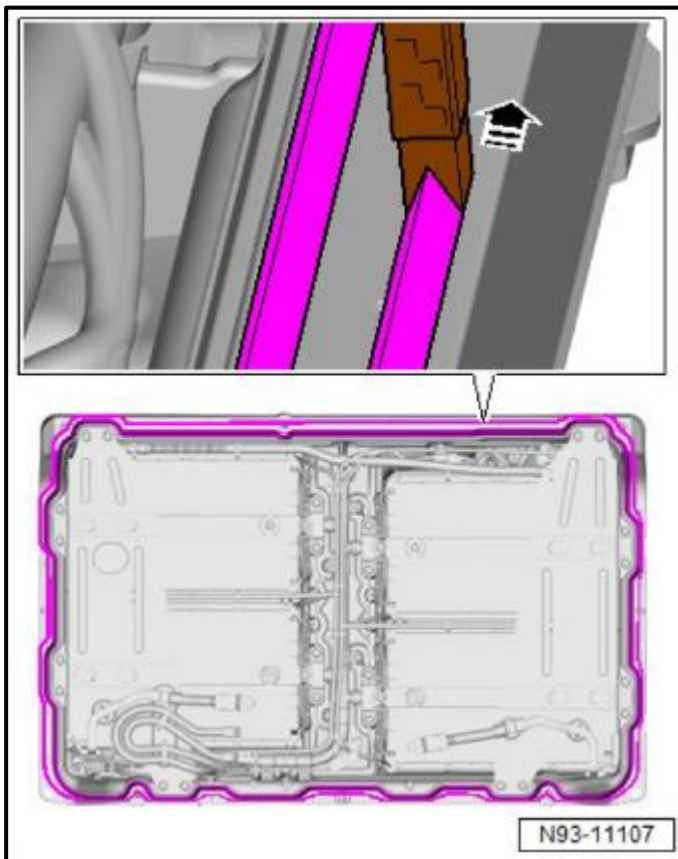

### Apply second bead:

- Apply a second adhesive bead parallel to the first adhesive bead.

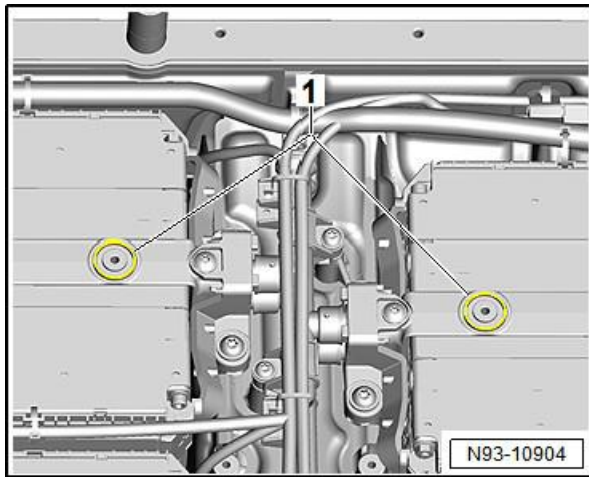

- Ensure seals are installed.

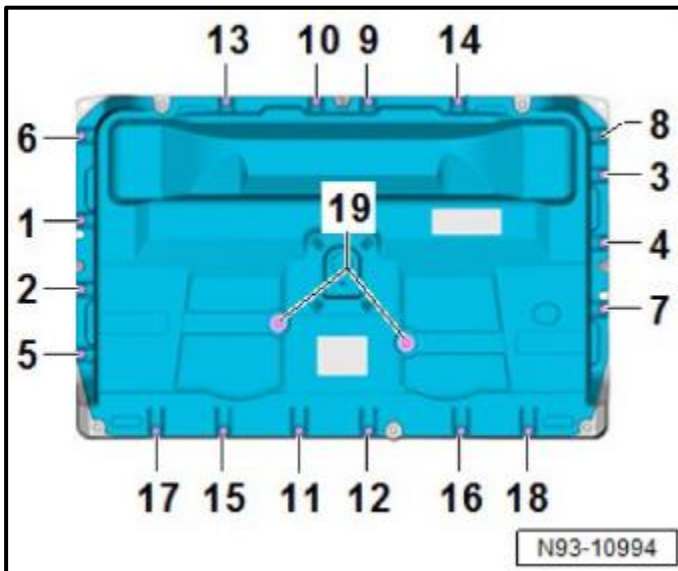

**Fit top section:**

**NOTE**

Adhesive bead must emerge all around after battery housing (top section) has been bolted on.

- Install new M6x12 bolts (from repair kit) by hand.

Part Number	Part Description
N/A	M6x12 Bolt

- Tighten bolts to 8 Nm in the sequence <1 to 19>.

**TIP**

Appendix G is a full page photo of the tightening sequence that can be printed so the tightening sequence can be followed easier.

**Spread adhesive:**

- Use a suitable paintbrush to spread any adhesive that comes out and fill gaps between top and bottom sections of battery housing.





#### Allow adhesive to cure:

- The minimum drying time for the adhesive is four hours.
- During the minimum drying time (i.e. the time between the bonding procedure and performing further work), high-voltage battery must be on the scissor-type assembly platform at room temperature (at least 15 °C/59 °F).

#### **i** TIP

Performing the bonding procedure at the end of the work day and allowing the adhesive to dry overnight is the best practice.

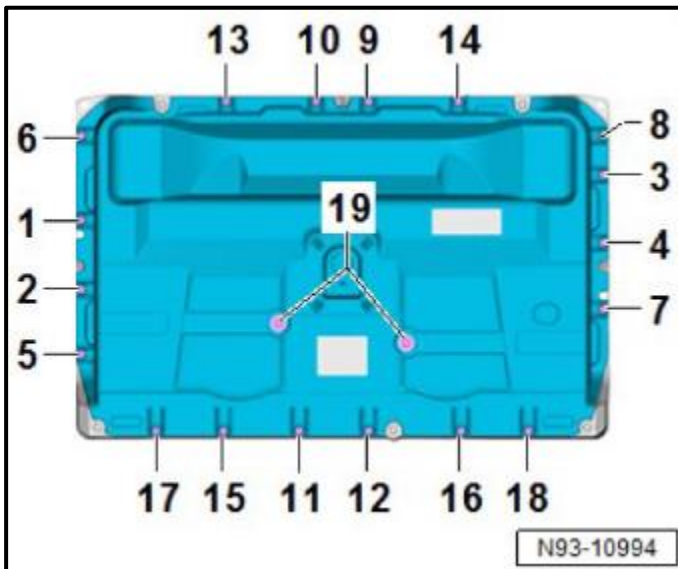

#### Apply wax to bolts:

- Apply cavity wax D 329.215.M1 (shop supply) over bolts <1 through 19>.

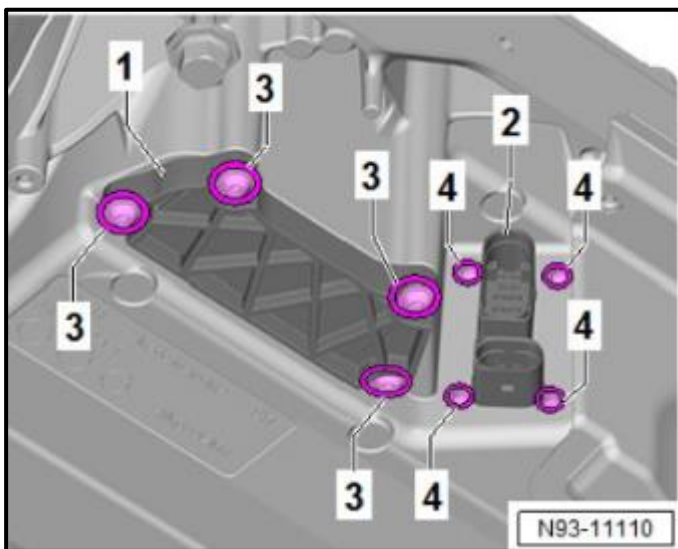

#### Seal J840 bolts and connections:

- Seal bolts <3> and <4> for battery regulation control unit -J840- <1> and connector housing <2> with butyl adhesive.

Part Number	Part Description
D 469.101.A3	Butyl adhesive

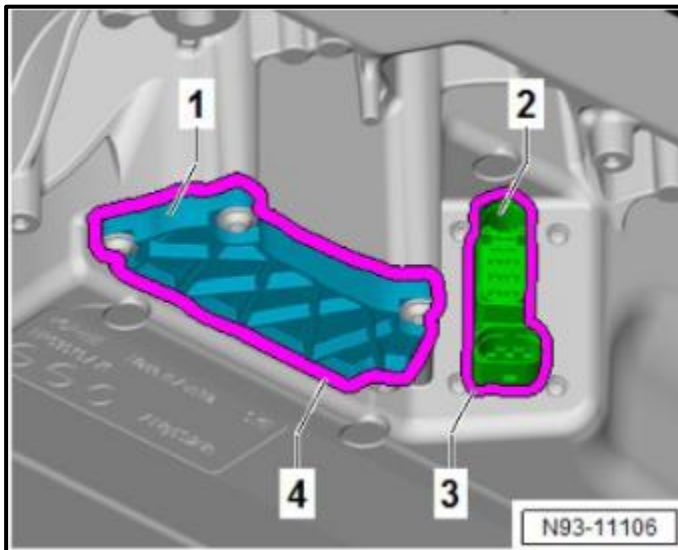

- Seal around battery regulation control unit - J840- <1> and connector housing <2> with butyl adhesive.
- Apply butyl adhesive <3> around connector housing <2> so that the electrical connectors can still be plugged in and released correctly.

Part Number	Part Description
D 469.101.A3	Butyl adhesive

#### Perform HV battery leak test:

- Test can only be performed after the minimum drying time has elapsed.
- Perform tests in the following order:
  4. Perform self-test on Leak Tester -VAS6911/3A-1-.
    - a. See Appendix C.
  5. Perform high-voltage battery acclimatization (pressure equalization) test.
    - a. See Appendix D.
  6. Perform high-voltage battery pressure test.
    - a. See Appendix E.

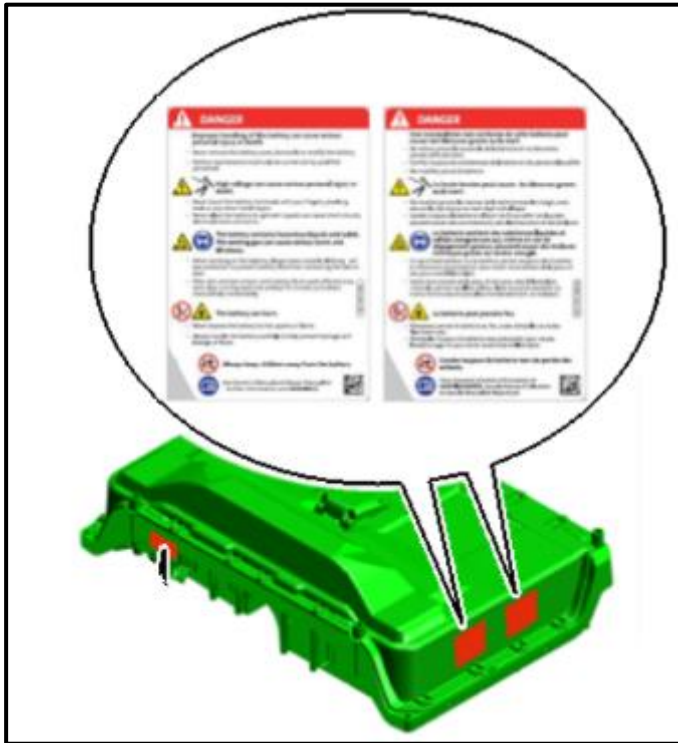

#### Attach warning labels:

- Ensure area is clean and free of debris or residue.
- Apply warning labels.

Part Number	Part Description
12E.010.006	Warning label (English)
12E.010.006.A	Warning label (French)

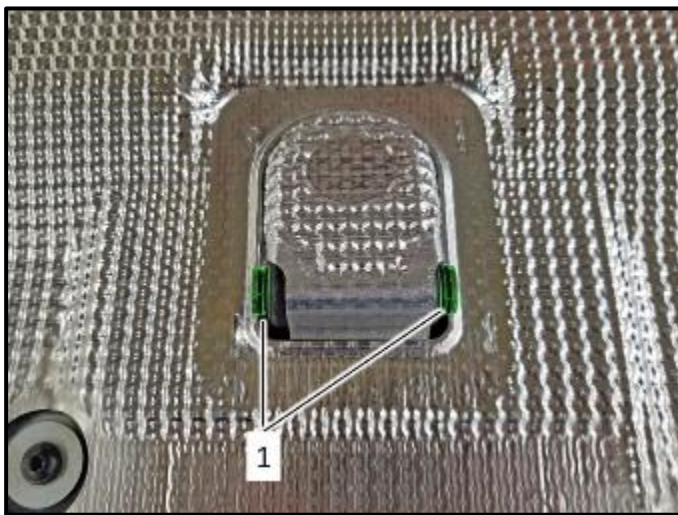

#### Install pressure release plugs:

- Install pressure release plugs <1> into the battery housing (top section).

Part Number	Part Description
5Q0.998.841.B	Pressure release plug (from battery housing repair kit)

- Ensure the plugs are fully seated.

#### Proceed to Section F

## Section E – High-Voltage Battery Replacement

### **⚠ WARNING**

- Work must be performed by high-voltage expert (HVE).
- After the voltage has been reduced, the affected high-voltage batteries can be sent with “normal” status (non-critical).
- After exchanging the high-voltage battery, the new battery must be sealed with butyl at the low-voltage connector and at the -J840- cover in accordance with the instructions, provided that these locations are not sealed on the new component.

### **ⓘ STORAGE AND DISPOSITION OF BATTERIES**

#### **U.S. Dealers:**

To arrange for recycling of the damaged/corroded cell, and to obtain appropriate packaging and markings, visit <https://a3.evbatteryreturns.com> and fill out a battery request form. While stored on-site at the dealership, the damaged/corroded cell module must be managed in accordance with universal waste requirements located at 40 CFR Part 273 and relevant state law.

To arrange for recycling of the battery pack, and to obtain appropriate markings, visit <https://a3.evbatteryreturns.com> and fill out a battery request form. The battery pack must be shipped in original packaging supplied by Audi of America. While stored on-site at the dealership, the battery pack must be managed in accordance with universal waste requirements located at 40 CFR Part 273 and relevant state law.

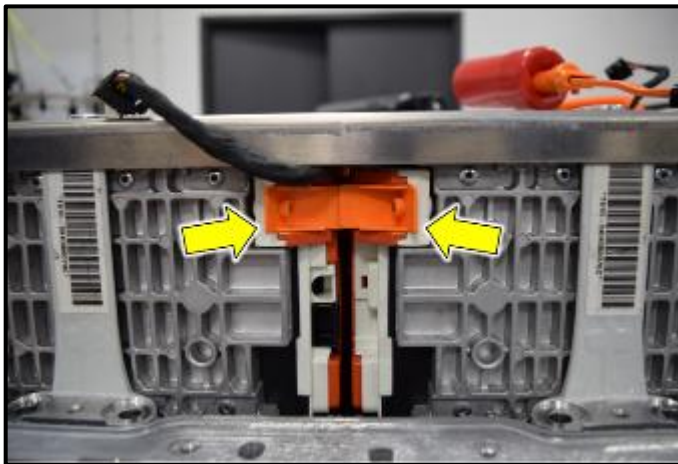

- The damaged/corroded cell module must be removed from the battery module assembly.
- The remaining cell modules must be secured to the battery housing (lower section).
- The voltage must be reduced on the remaining cell modules by removing high-voltage cables and installing caps -T10544- <arrows> where the cables used to be secured.
- Once the modules are secured in the battery housing (lower section) and the voltage is reduced, install and secure the original battery housing (top section).
- The old battery housing with battery pack will be recycled (see “STORAGE AND DISPOSITION OF BATTERIES” above).

### **ⓘ NOTE**

Dealers were auto-shipped an initial quantity of five of the -T10544-.

Additional caps are orderable in quantities of 30 from the Audi Special Tools and Equipment program: [audi.snapon.com](http://audi.snapon.com)

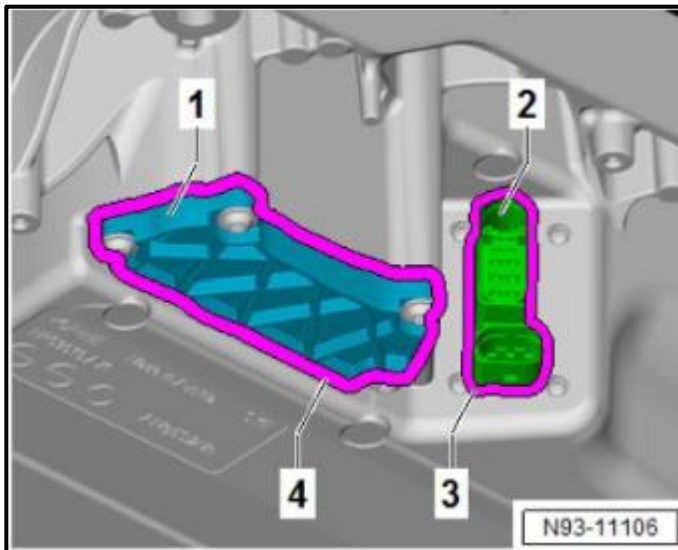

**Apply additional seal to the new high voltage battery (if necessary):**

- If necessary, seal around battery regulation control unit -J840- <1> and connector housing <2> with butyl adhesive.
- If necessary, apply butyl adhesive <3> around connector housing <2> so that the electrical connectors can still be plugged in and released correctly.

Part Number	Part Description
D 469.101.A3	Butyl adhesive

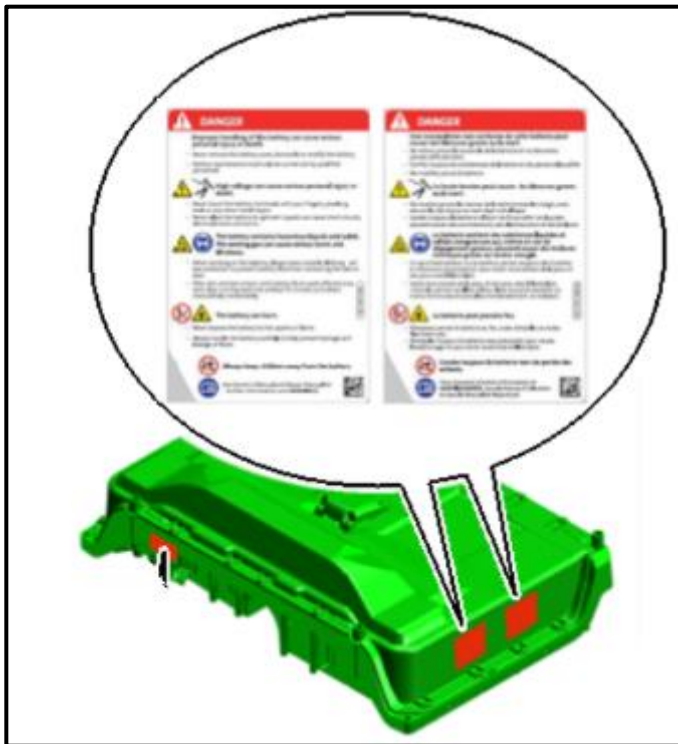

**Attach warning labels (if necessary):**

- Ensure area is clean and free of debris or residue.
- Apply warning labels.

Part Number	Part Description
12E.010.006	Warning label (English)
12E.010.006.A	Warning label (French)

**Proceed to Section F**



## Section F – Reinstalling High-Voltage Battery Into Vehicle

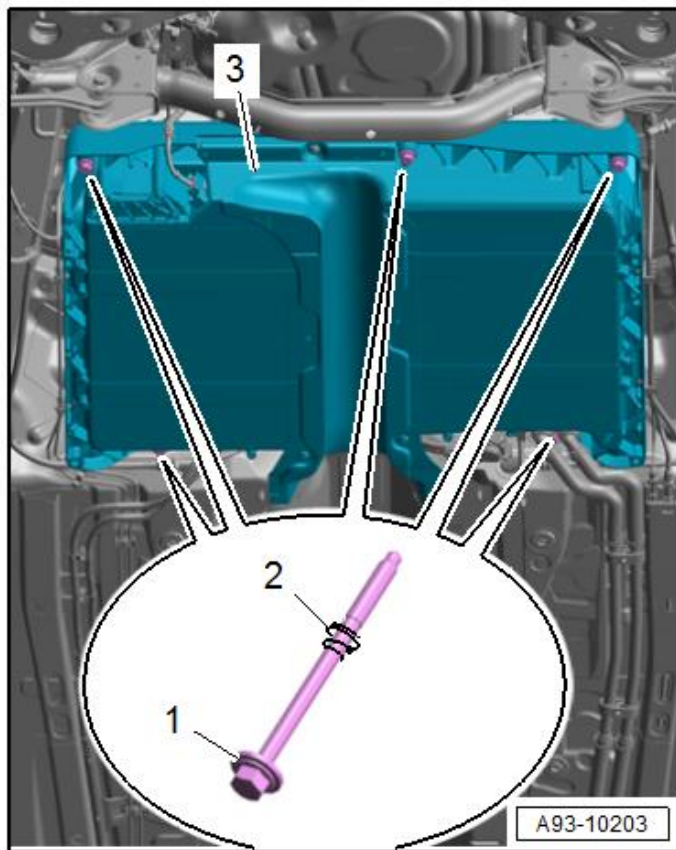

### Install high-voltage battery:

- Raise battery to the vehicle using the scissor lift table.
- Start all bolts <1> by hand.
- Torque bolts <1> to 50 Nm + 270°.

#### **i** TIP

The new battery housing (bottom section) and a new high-voltage battery will come with bolts <1> and retainers <2>.

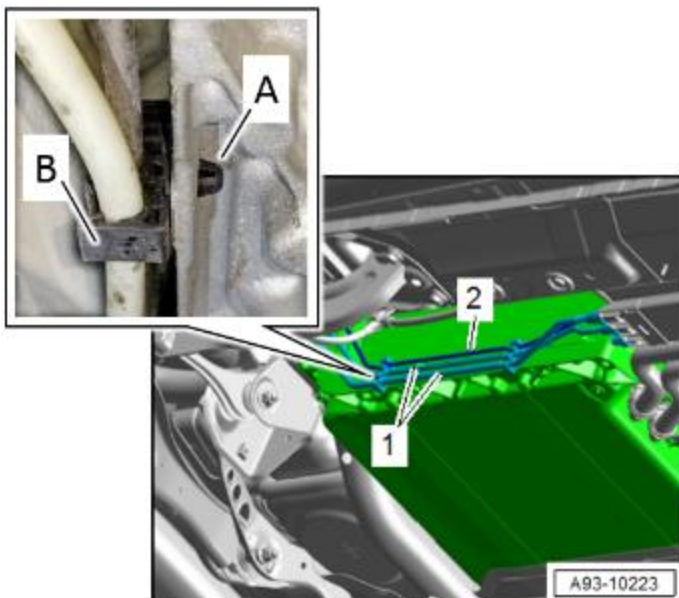

### Install fuel lines:

- Install fuel lines <1> into new clips <B>.

Part Number	Part Description
5Q0.201.449.AE	Fuel line retaining clip (x2)

- Ignore item <2>.
- Ensure locking tab <A> is fully engaged.

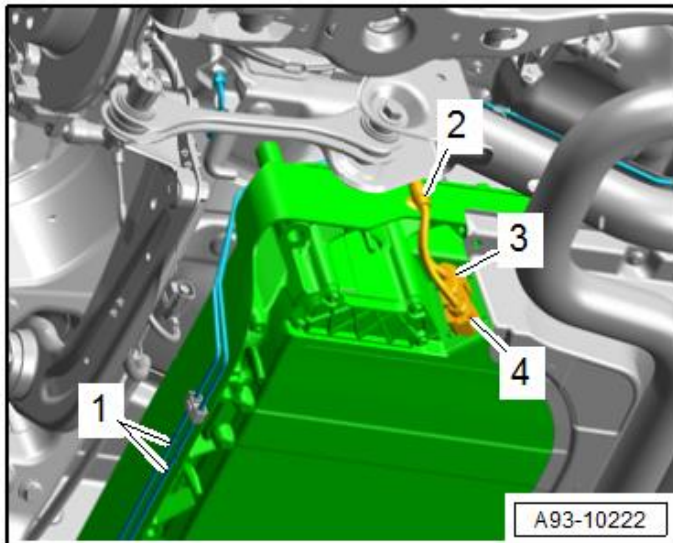

#### Install brake lines and electrical connectors.

- Install brake lines <1> into retainers.
- Plug in electrical connectors.

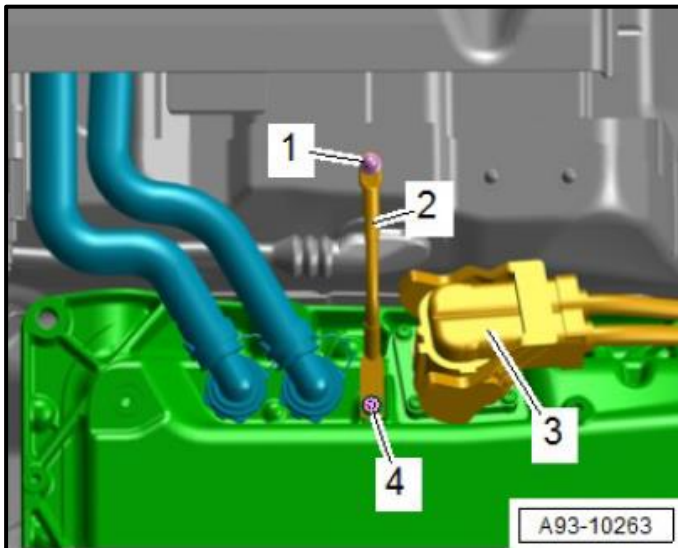

#### Install potential equalization line and electrical connector :

- Remove transportation cap.
- Connect electrical connector <3>.
- Remove potential equalization line <2> and torque bolts <1 and 4> to 9 Nm.

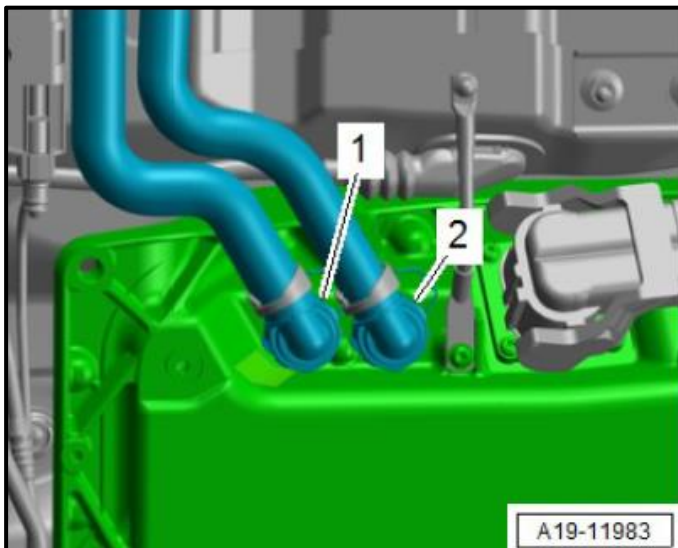

#### Install coolant hoses:

- Install coolant hoses and secure retaining clips <1> and <2>.

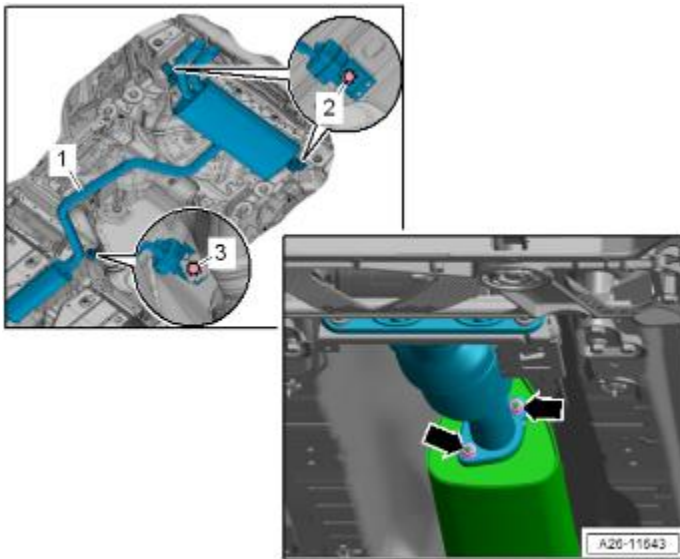

### Install exhaust:

- Installation is the reverse of removal.
- Torque exhaust mount bolts <2> and <3> to 20 Nm.
- Install new gasket and torque new nuts <arrows> to 20 Nm.

Part Number	Part Description
1K0.253.115.M	Muffler gasket
N 022.146.9	Nut (x2)

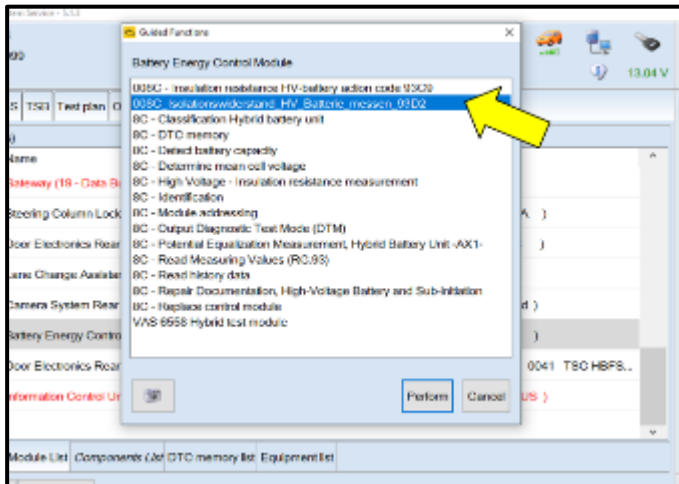

### Re-energize high-voltage system and perform potential equalization test:

- Use test plan "008C\_Isolationswiderstand\_HV\_Batterie\_messen\_93D2" under address word 008C.

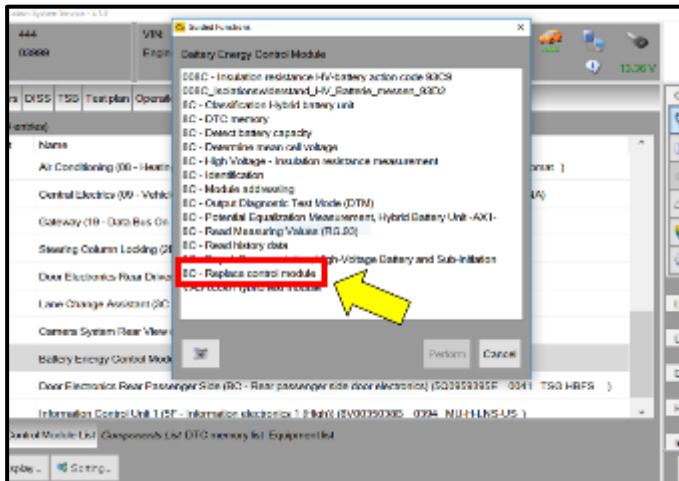

### If high-voltage battery was replaced, perform J840 replacement test plan:

- Select the Guided Functions test plan "8C – Replace control module" under address word 008C.

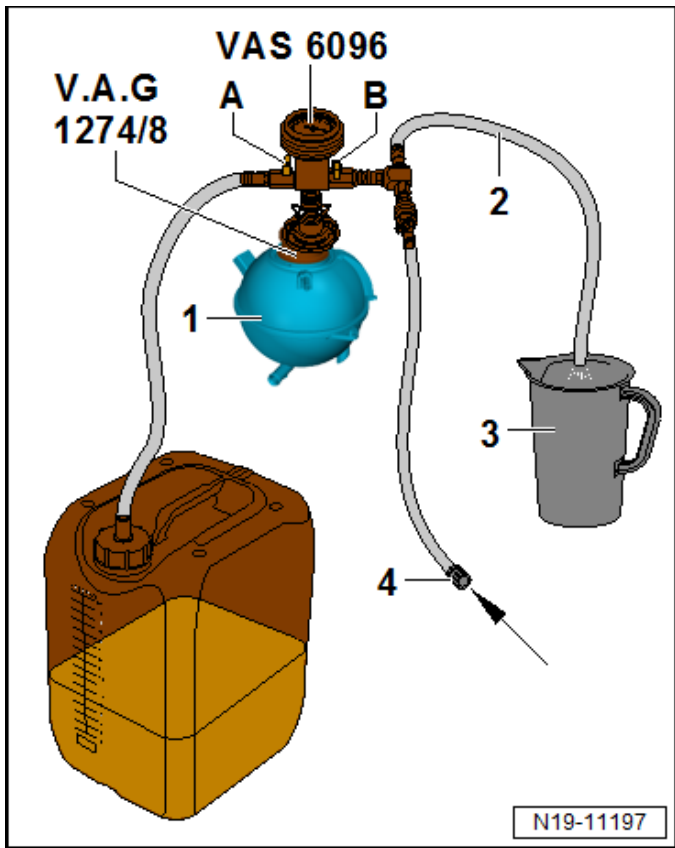

**Fill coolant:**

**NOTE**

- Coolant (40%) and distilled water (60%) for freeze protection down to -25 °C (-13 °F)
- Coolant (50%) and distilled water (50%) for freeze protection down to -36 °C (-32.8 °F)
- Refer to ETKA for the correct coolant.

- See ELSA Repair Manual: *Repair manual > Engine > 4-Cylinder Direct Injection 1.2L; 1.4L 4V TFSI Engine (EA211) > 19 Cooling System > Coolant System/Coolant > Coolant, Draining and Filling > Coolant, Filling, High-Voltage System Cooling Components*
- Perform ODIS “Cooling system filling/bleeding” test plan as required.
- Follow on screen prompts.

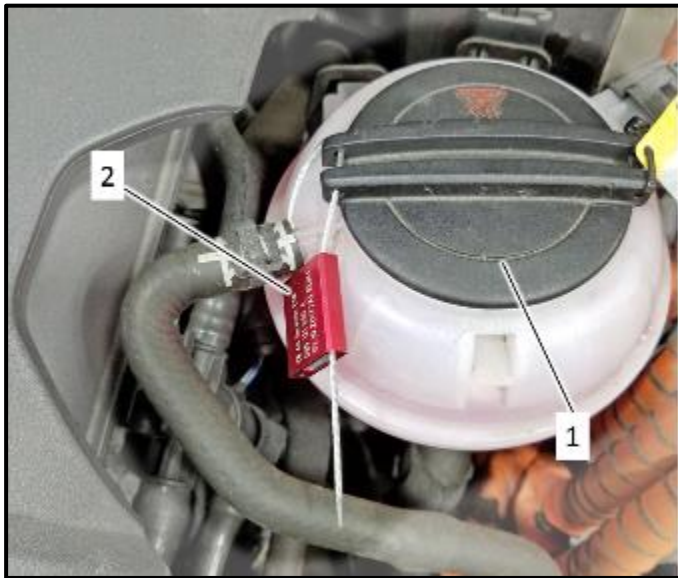

**Install coolant expansion tank cap:**

- Install expansion tank cap <1>.
- Secure the cap <1> with new seal <2>.

Part Number	Part Description
5Q0.121.809.A	Seal

- Ensure the cable of the seal <2> is wrapped around the return hose so that the cap <1> cannot be removed.

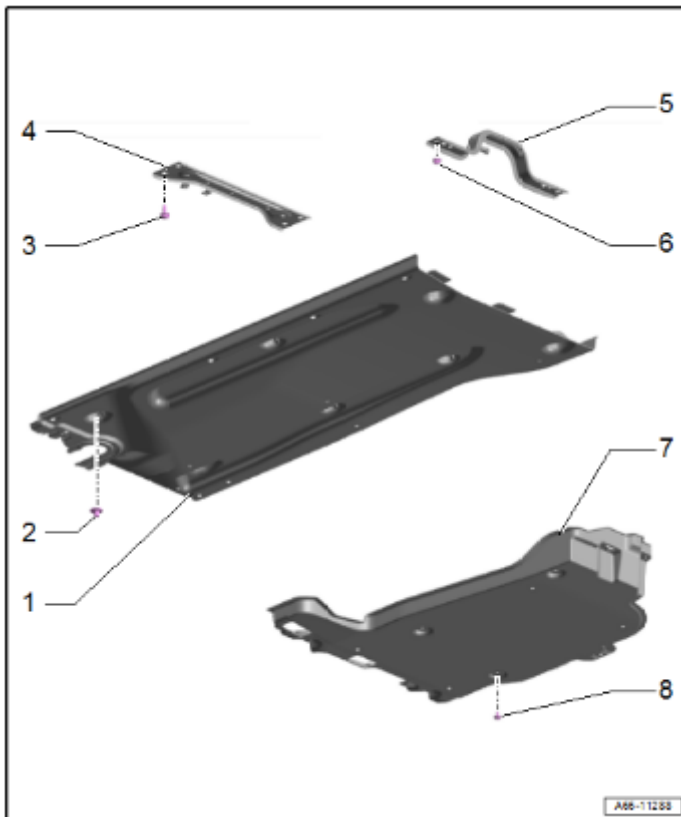

#### Install underbody trim panels:

- Installation is the reverse order of removal.
- Torque bolts <3> and <6> for braces to 20 Nm.
- Torque remaining fasteners to 2 Nm.

#### Final steps:

- Clear all repair related faults using Guided Fault Finding.
- Exit GFF and send diagnostic protocol online when prompted.

#### Proceed to Section G

## Section G – Campaign Completion Stamp

I certify that this campaign has been performed in strict accordance with the applicable Audi repair procedure.

SAGA Code: \_\_\_\_\_

Technician: \_\_\_\_\_

Date: \_\_\_\_\_

Item#: AUD4927ENG

-OR-

Je certifie que cette campagne de rappel a été exécutée suivant les strictes directives de réparation d'Audi

Code de SAGA: \_\_\_\_\_

Technicien: \_\_\_\_\_

Date: \_\_\_\_\_

Item # AUD4927FRE

- Once the campaign has been completed, the technician should stamp the repair order.
- Stamps are available for ordering through the Compliance Label Ordering Portal.
- **Proceed to Section H.**

## Section H - Parts Return/Disposal

Properly store (retain), destroy or dispose of removed parts in accordance with all state/province and local requirements, unless otherwise indicated and/or requested through the Warranty Parts Portal (WPP) for U.S. and the Part Destruction and Core Disposition Report for Canada.

### U.S. Dealers:

Cell modules with corrosion and battery assemblies replaced during the 93F1 Service Action must be properly recycled, see Section E of the 93F1 Service Action Circular. Dealers must use Kinsbursky Brothers Intl. (KBI) to facilitate the recycling of corroded cell modules and battery assemblies.

Dealers will work directly with KBI to coordinate the return of any cell modules with signs of corrosion and battery assemblies related to the 93F1 Service Action. KBI will supply dealers with the necessary shipping labels and special packaging for the return of each corroded cell module. Battery assemblies must be returned in the replacement battery packaging.

After completing the 93F1 Service Action dealers should refer to **Appendix G (A3 Battery Service Action Portal User Instructions)** in the circular and do the following:

- Registration (One time only)
  - Visit the A3 e-tron website at <https://a3.evbatteryreturns.com> and register the dealership with KBI
- Module and Battery Returns
  - Complete the Battery Return Request Form through the A3 Battery Service Action Portal
  - Return of Corroded Cell Modules and Batteries
    - Pack the corroded cell modules in the KBI provided packaging; one module per package
    - Pack the battery assembly in the packaging from the new battery
    - Use the KBI provided Bill of Lading, hazardous material labels and markings
      - You must retain a copy of the Bill of Lading for 2 years per the (DOT) Department of Transportation and/or 3 years if you are Universal Waste Handler in California or a Large Quantity Handler of Universal Waste in any other state
- Tracking
  - Use the A3 Battery Service Action Portal to track the module and battery shipments

- Once the shipments are received download Certificate of Acceptance for each shipment and retain with the repair order
- Transportation and Recycling Cost Reconciliation
  - Refer to the Claim Entry Instructions section in the 93F1 Service Action Circular on how to submit for reimbursement of the transportation and recycling costs accrued with the return and recycling of the modules and battery.

## Appendix A – Cooling System Tester -VAS691005/1- Self-Test

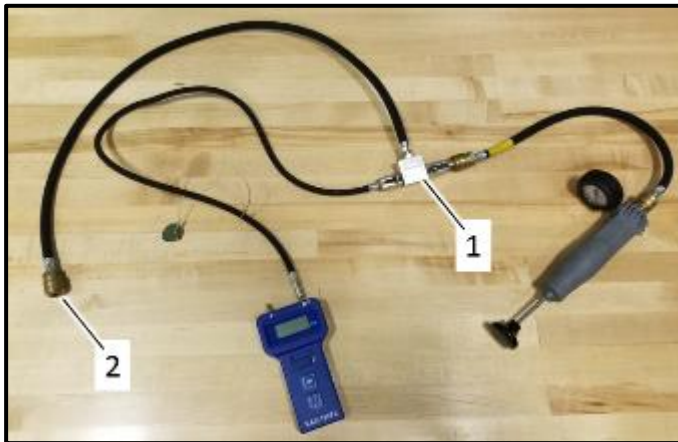

- This test ensures the -VAS691005/1- <1> does not leak.
- Test can be done with either -VAS1397A- or -VAS1397B-.
- No other tools should be attached to the -VAS691005/1- connection B <2>.
- -VAS1397A- shown.

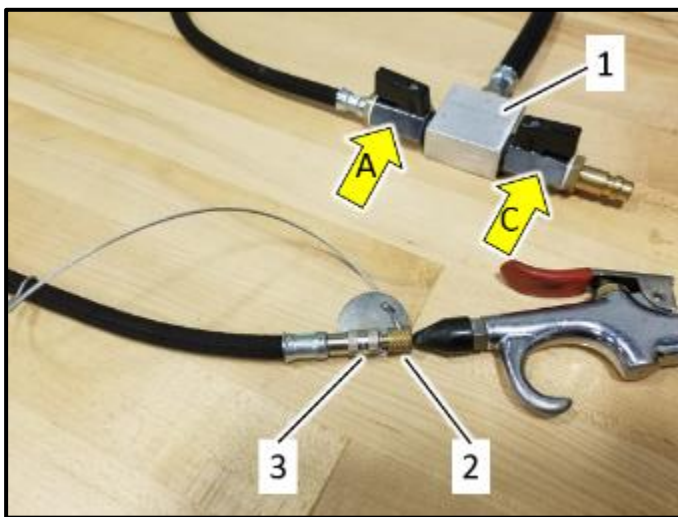

### Clean -VAS691005/1-:

- No other tools should be attached to the -VAS691005/1- <1>.
- Connect cleaning nozzle <2> to connection A <3>.
- Open cut-off valves A and C <arrows>.
- Clean -VAS691005/1- with compressed air.

### NOTE

The -VAS691005/1- must be cleaned before and after the cooling system leak test.

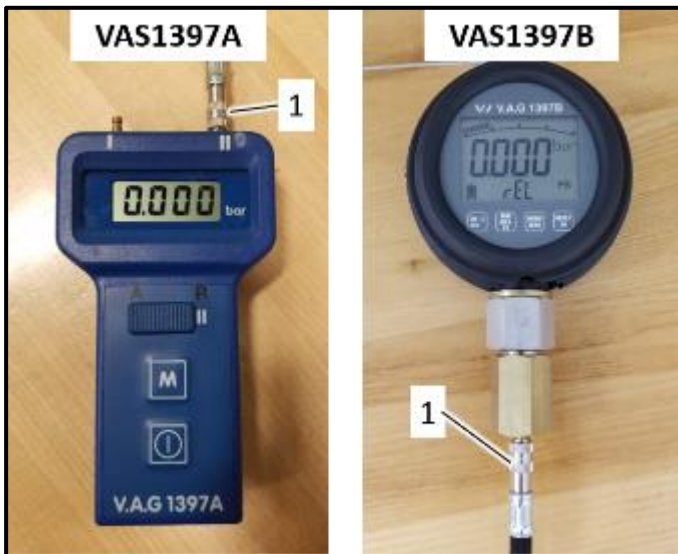

### Performing -VAS691005/1- self test:

- Using VAS1397A:
  - Attach connection A <1> of -VAS691005/1- to connection II on turbocharger tester -VAG1397A-.
- Using VAS1397B:
  - Attach connection A <1> of -VAS691005/1- to connection II on turbocharger tester -VAG1397B-.



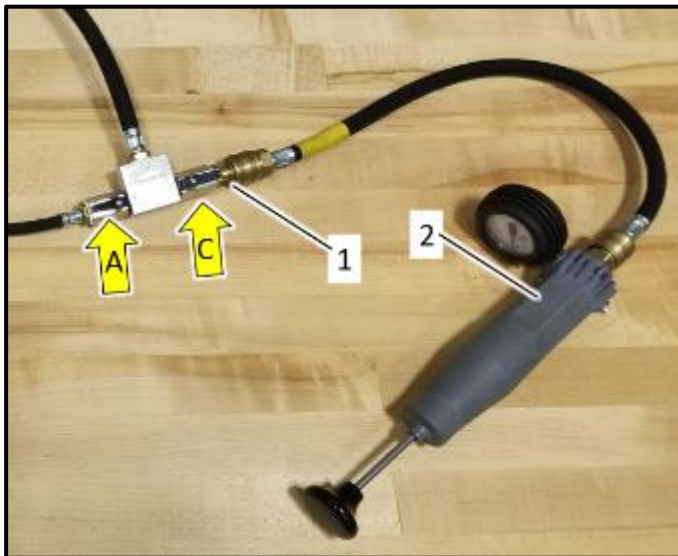

- Connect connection C of -VAS691005/1- to hand pump -VAG1274B-.
- Open cut-off valves A and C <arrows> on -VAS691005/1-.

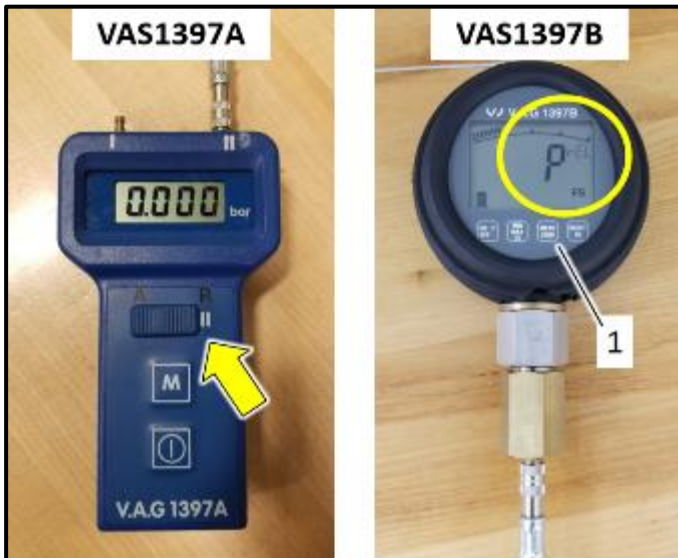

- Using -VAG1397A-:
  - Turn on turbocharger tester -VAG1397A-.
  - Select setting II <arrow>.
- Using -VAG1397B-:
  - Turn on turbocharger tester -VAG1397B-.
  - Press the menu button <1> until the relative pressure setting (P-rel) is displayed <circle>.
  - Wait approximately 30 seconds for tester to calibrate.
  - Display will then read 0.000.



**⚠ CAUTION**

**Risk of Tool Damage!**

Do not exceed 2.99 bar or irreparable damage to the tool will occur.

- Using hand pump -VAG1274B-, build up pressure until turbocharger tester -VAG1397A/B- reads approximately 2.5 bar.



- Close cut-off valve C <arrow> on -VAS691005/1-.



## Stabilize

- Allow pressure to stabilize for one minute.



## Pressure loss < 0 mbar = OK

- After the pressure is stable, wait 30 seconds and check pressure drop on turbocharger tester -VAG1397A/B-.
- If there is no pressure loss after one minute, then the -VAS691005/1- is OK.

## Appendix B – High-Voltage Battery Cooling System Leak Test

- This test ensures the cooling system is properly sealed prior to sealing the high-voltage battery housing.
- Test can be done with either -VAS1397A- or -VAS1397B-.
- Seal off coolant connection <1> on high-voltage battery with sealing plug -VAS691005/3-.
- Connect cooling system test adapter -VAS691005/4- to coolant connection <2> on high-voltage battery.
- Connect connection B <3> of -VAS691005/1- to test adapter -VAS691005/4- <2>.

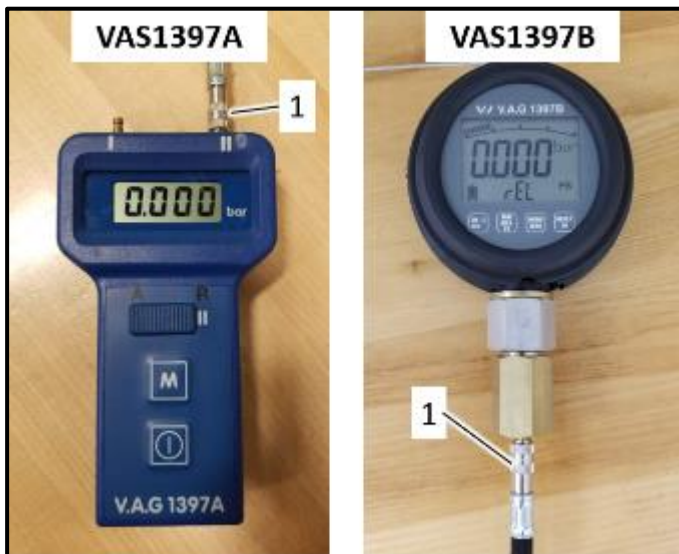
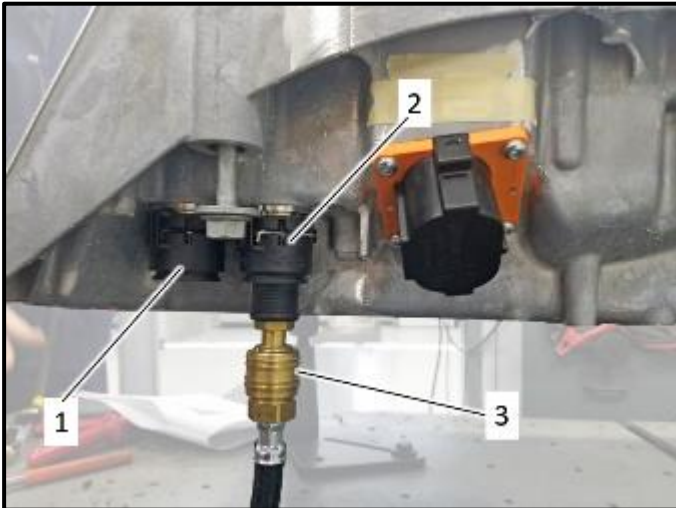

- Using VAG1397A:
  - Attach connection A <1> of -VAS691005/1- to connection II on turbocharger tester -VAG1397A-.
- Using VAG1397B:
  - Attach connection A <1> of -VAS691005/1- to connection II on turbocharger tester -VAG1397B-.

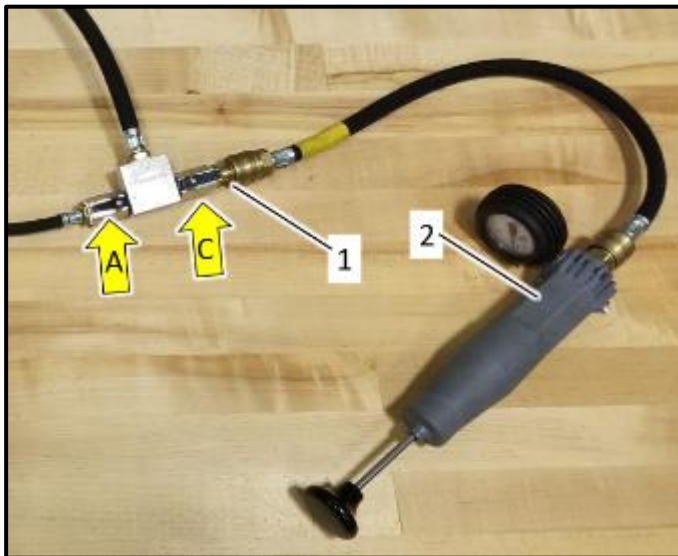

- Connect connection C of -VAS691005/1- to hand pump -VAG1274B-.
- Open cut-off valves A and C <arrows> on -VAS691005/1-.

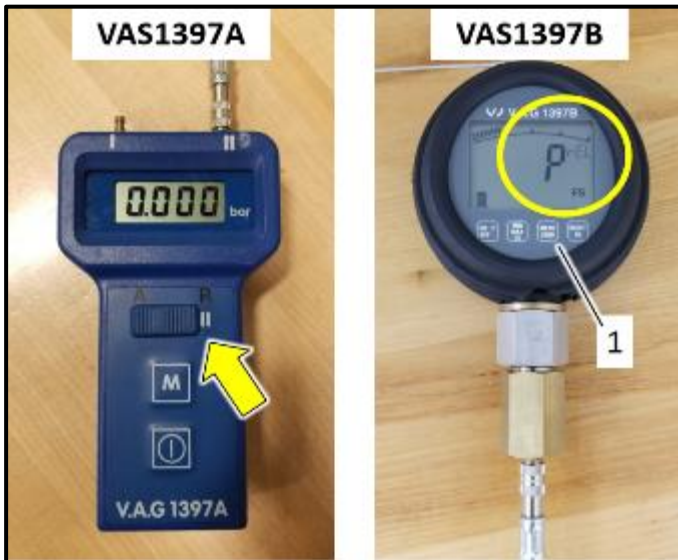

- Using -VAG1397A-:
  - Turn on turbocharger tester -VAG1397A-.
  - Select setting II <arrow>.
- Using -VAG1397B-:
  - Turn on turbocharger tester -VAG1397B-.
  - Press the menu button <1> until the relative pressure setting (P-rel) is displayed <circle>.
  - Wait approximately 30 seconds for tester to calibrate.
  - Display will then read 0.000.



**CAUTION**

**Risk of Tool Damage!**

Do not exceed 2.99 bar or irreparable damage to the tool will occur.

- Using hand pump -VAG1274B-, build up pressure until turbocharger tester -VAG1397A- reads 2.5 bar.



- Close cut-off valve C <arrow> on -VAS691005/1-.



## Stabilize

- Allow pressure to stabilize for one minute.



**Pressure loss  
< 0.020 bar =  
OK**

- After the pressure is stable, wait 10 minutes and check pressure drop on turbocharger tester -VAG1397A/B-.
- If pressure drop does not exceed 0.020 bar after 10 minutes, then the cooling system is OK.

## Appendix C – -VAS6911/3A- Adapter Self-Test



- This test ensures the -VAS6911/3A- <1> does not leak.
- Test can be done with either -VAS1397A- or -VAS1397B-.
- -VAS1397B- shown.

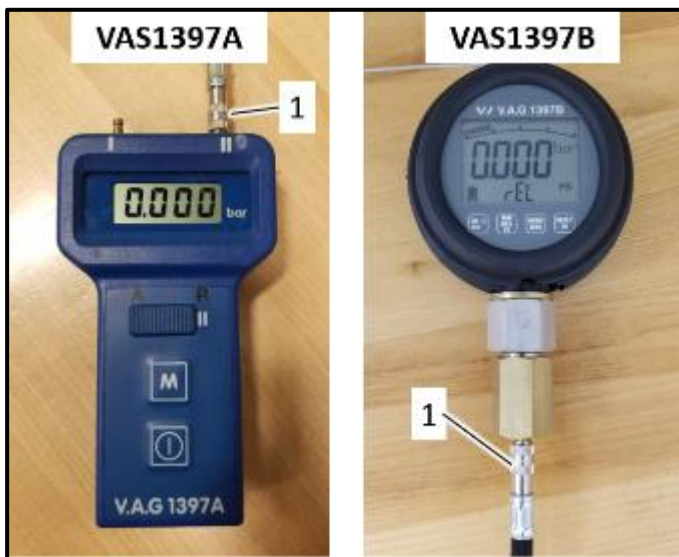

- Using VAG1397A:
  - Attach connection A <1> of -VAS691005/1- to connection II on turbocharger tester -VAG1397A-.
- Using VAG1397B:
  - Attach connection A <1> of -VAS691005/1- to connection II on turbocharger tester -VAG1397B-.

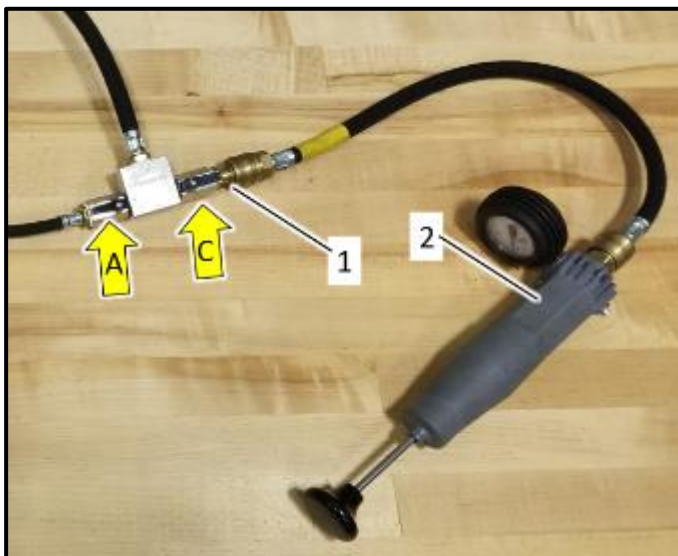

- Connect connection C of -VAS691005/1- to hand pump -VAG1274B-.
- Open cut-off valves A and C <arrows> on -VAS691005/1-.

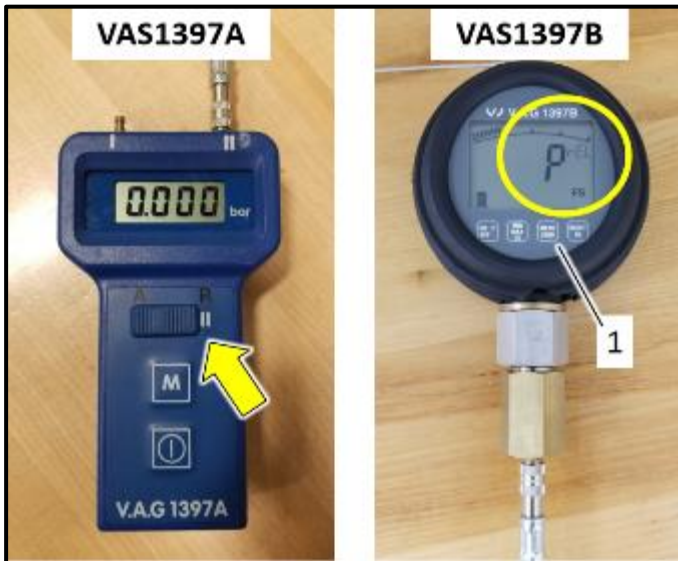

- Using -VAG1397A-:
  - Turn on turbocharger tester -VAG1397A-.
  - Select setting II <arrow>.
- Using -VAG1397B-:
  - Turn on turbocharger tester -VAG1397B-.
  - Press the menu button <1> until the relative pressure setting (P-rel) is displayed <circle>.
  - Wait approximately 30 seconds for tester to calibrate.
  - Display will then read 0.000.



**⚠ CAUTION**

**Risk of Tool Damage!**

Do not exceed 2.99 bar or irreparable damage to the tool will occur.

- No other tools should be attached to the -VAS691005/1-.
  - Using hand pump -VAG1274B-, build up pressure until turbocharger tester -VAG1397A/B- reads between 0.300 and 0.350 bar (300 - 350 mbar).
- 
- Close cut-off valve C <arrow> on -VAS691005/1-.





## Stabilize

- Allow pressure to stabilize for one minute.



## Pressure loss < 5 mbar = OK

- After the pressure is stable, wait 30 seconds and check pressure drop on turbocharger tester -VAG1397A/B-.
- If pressure drop does not exceed 5 mbar after 30 seconds, then the -VAS6911/3A- is OK.



## Appendix D – High-Voltage Battery Acclimation Test

- This test ensures the pressure inside the high-voltage battery housing has stabilized. This will ensure an accurate reading during the high-voltage battery pressure test.
- **Do not place any objects on the high-voltage battery.**
- Leave cut-off valve C open on -VAS691005/1- when assembling the tools. Otherwise, damage to the pressure gauge -VAS611013- may occur.
- This test must be performed under constant temperature conditions.
- Test block <1> is removed from the -VAS6911/3A- <2>.

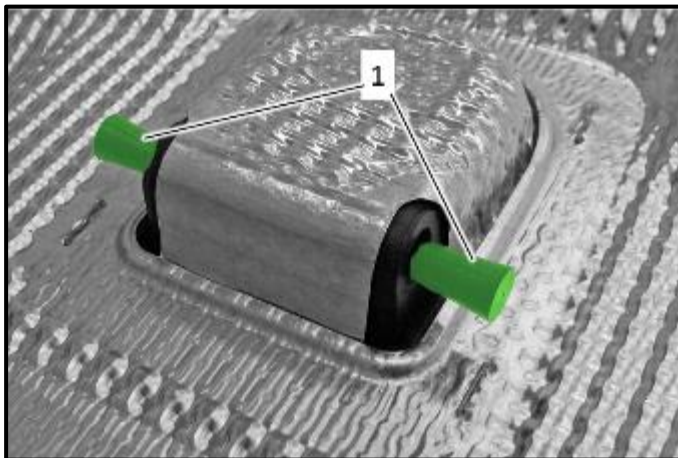
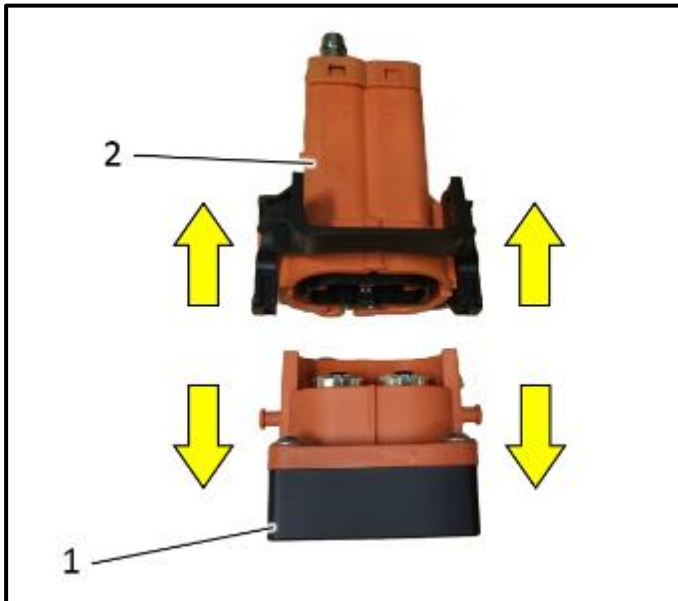

- Seal pressure equalization openings on battery housing (top section) with sealing plugs -VAS6911/15- <1>.



- Ensure cut-off valves A and C are open on -VAS691005/1- when connecting tools.

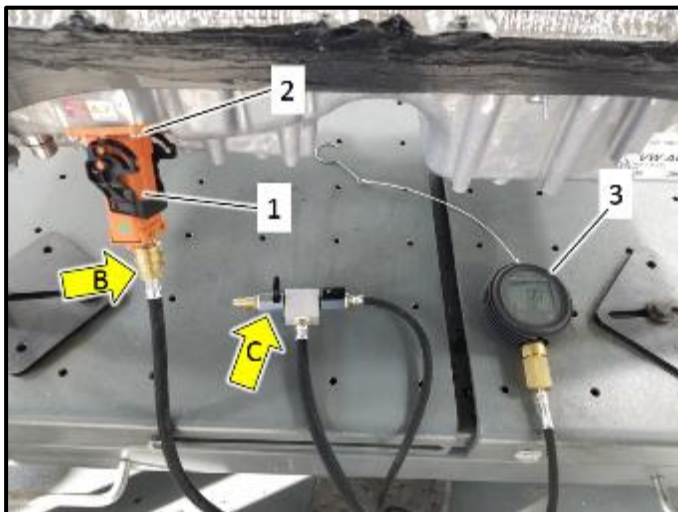

- Attach connection B of the -VAS691005/1- to the -VAS6911/3A- <1>.
- Attach -VAS6911/3A- <1> to the high-voltage battery connection <2>.
- Close cut-off valve C on -VAS691005/1-.
- Observe the pressure reading on the -VAS611013- <3>.



**Pressure  
increase < 0.5  
mbar = OK**

- After five minutes, the pressure should not increase by more than 0.5 mbar.
- If pressure does increase by more than 0.5 mbar, wait another 5 minutes to allow the pressure inside the battery housing to acclimate.

## Appendix E – High-Voltage Battery Pressure Test

- This test ensures the high-voltage battery does not leak.
- This test must be performed with pressure gauge -VAS611013-.
- **Do not place any objects on the high-voltage battery.**
- Leave cut-off valve C open on -VAS691005/1- when assembling the tools. Otherwise, damage to the pressure gauge -VAS611013- may occur.
- This test must be performed under constant temperature conditions.
- Test block <1> is removed from the -VAS6911/3A- <2>.

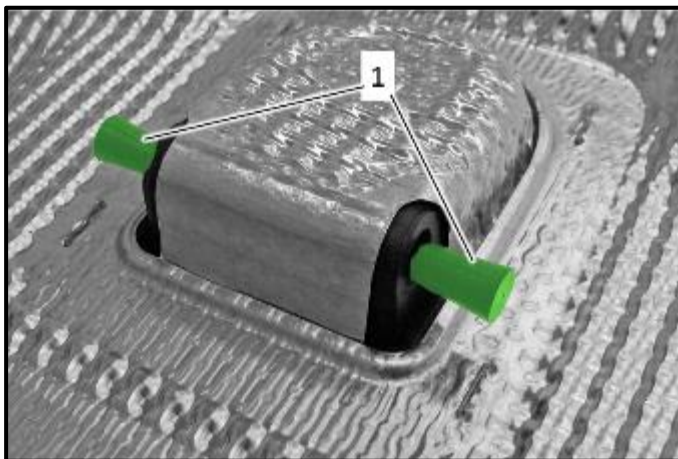
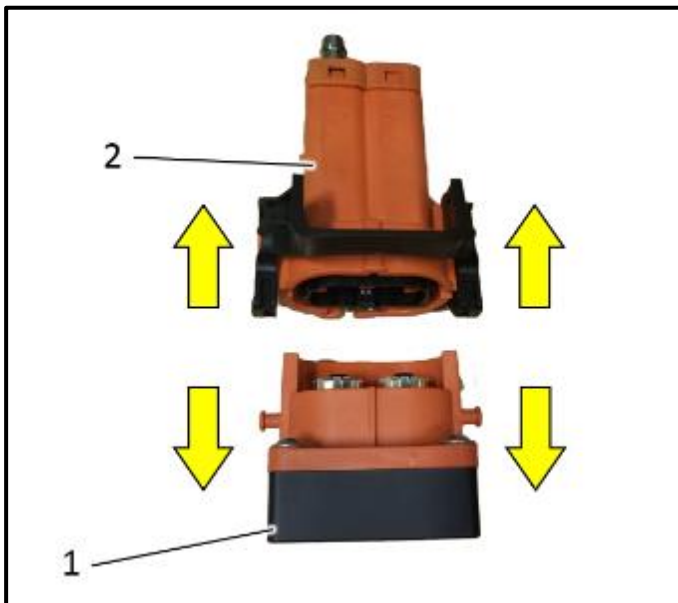

- Ensure the pressure equalization openings on battery housing (top section) are sealed with sealing plugs -VAS6911/15- <1>.



- Ensure cut-off valves A and C are open on -VAS691005/1- when connecting tools.

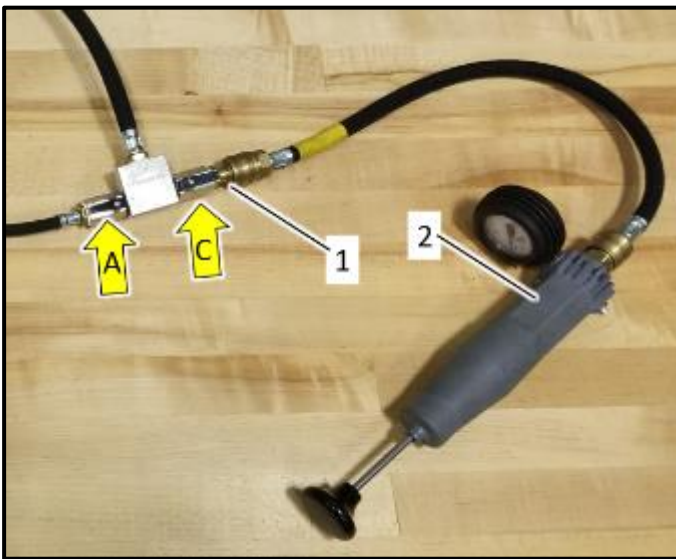

- Connect connection C of -VAS691005/1- to hand pump -VAG1274B-.
- Open cut-off valves A and C <arrows> on -VAS691005/1-.

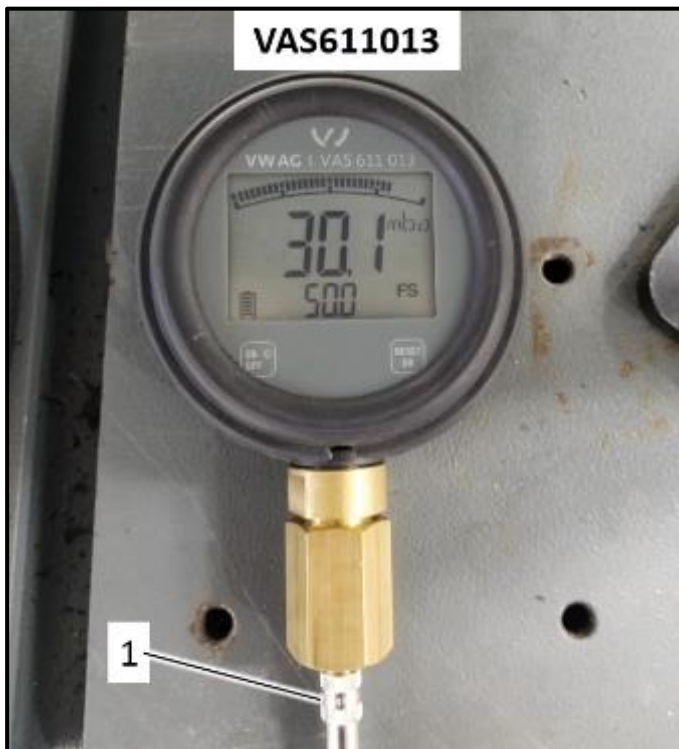

- Connection A <1> of -VAS691005/1- is attached to pressure gauge -VAS611013-.



- The -VAS6911/3A- <1> is attached to the high-voltage battery connection <2>.
- Connection B of the -VAS691005/1- is attached to the -VAS6911/3A- <1>.



**CAUTION**

**Risk of Tool Damage!**

Do not exceed **35 mbar** or irreparable damage to the tool will occur.

- Turn on pressure tester -VAS611013-.
- Using hand pump -VAG1274B-, build up pressure until pressure gauge -VAS611013- reads 30.1 or 30.2 mbar.



- Close cut-off valve C <arrow> on -VAS691005/1-.



## Stabilize

- Allow pressure to stabilize for one minute.



**Pressure loss  
< 9 mbar = OK**

- After the pressure is stable, wait 10 minutes and check pressure drop on turbocharger tester -VAS611013-.
- If pressure drop does not exceed 9 mbar after 10 minutes:
  - The high-voltage battery is OK.
- If pressure drop exceeds 9 mbar after 10 minutes:
  - Generate pressure as outlined in this High-voltage battery pressure test.
  - Spray battery housing seams and other areas with soapy water to find the leak.
  - The sealing plugs for the pressure equalization are also locations where leaks can potentially occur.

Appendix F – Battery Housing Bolt Torque Sequence

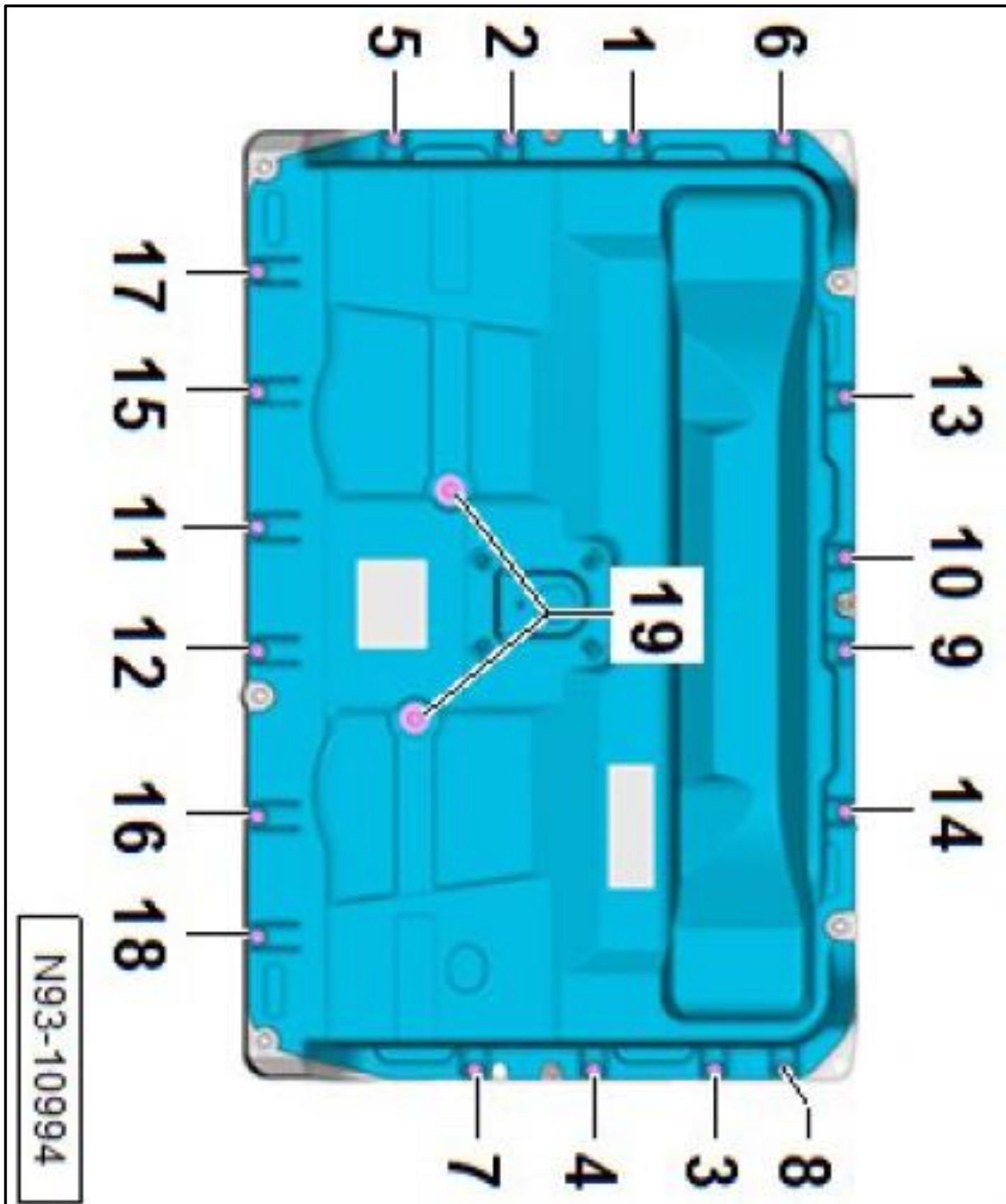

N93-10994



## Register New User Account

1. Navigate to the A3 Battery Recall Portal: <https://a3.evbatteryreturns.com/>
2. On the Sign In screen, click the New User tab.

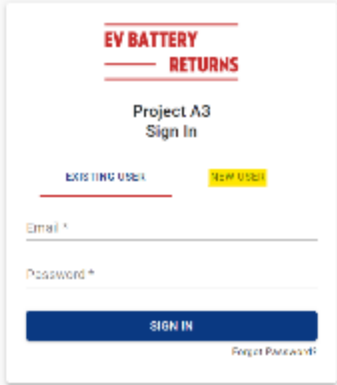

The screenshot shows the 'Project A3 Sign In' page. At the top, it says 'EV BATTERY RETURNS'. Below that, 'Project A3 Sign In'. There are two tabs: 'EXISTING USER' and 'NEW USER', with 'NEW USER' selected. Below the tabs are two input fields: 'Email \*' and 'Password \*'. At the bottom, there is a blue 'SIGN IN' button and a link for 'Forgot Password?'.

3. Complete all required fields and click the Continue button.

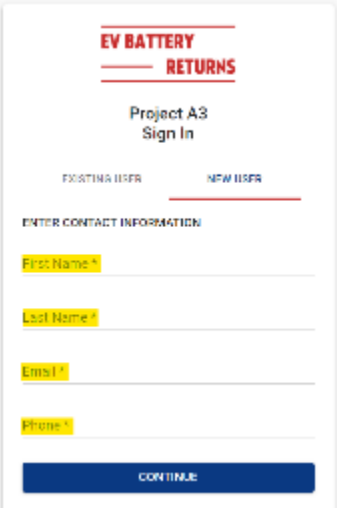

The screenshot shows the 'Project A3 Sign In' page with the 'NEW USER' tab selected. Below the tabs, it says 'ENTER CONTACT INFORMATION'. There are four input fields: 'First Name \*', 'Last Name \*', 'Email \*', and 'Phone \*'. At the bottom, there is a blue 'CONTINUE' button.

4. Enter a unique password, confirm that password and click the Register User button.

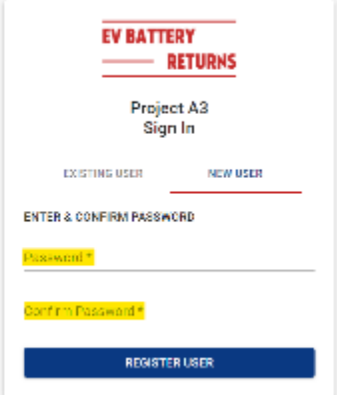

The screenshot shows the 'Project A3 Sign In' page with the 'NEW USER' tab selected. Below the tabs, it says 'ENTER & CONFIRM PASSWORD'. There are two input fields: 'Password \*' and 'Confirm Password \*'. At the bottom, there is a blue 'REGISTER USER' button.

5. After successful registration, you will be sent an email with a link to verify your account email address. NOTE: You will not be able to log into the portal until after your account has been verified. If you do not receive the account verification email, be sure to whitelist our domain (evbatteryreturns.com) to prevent emails from being sent to your spam folder.

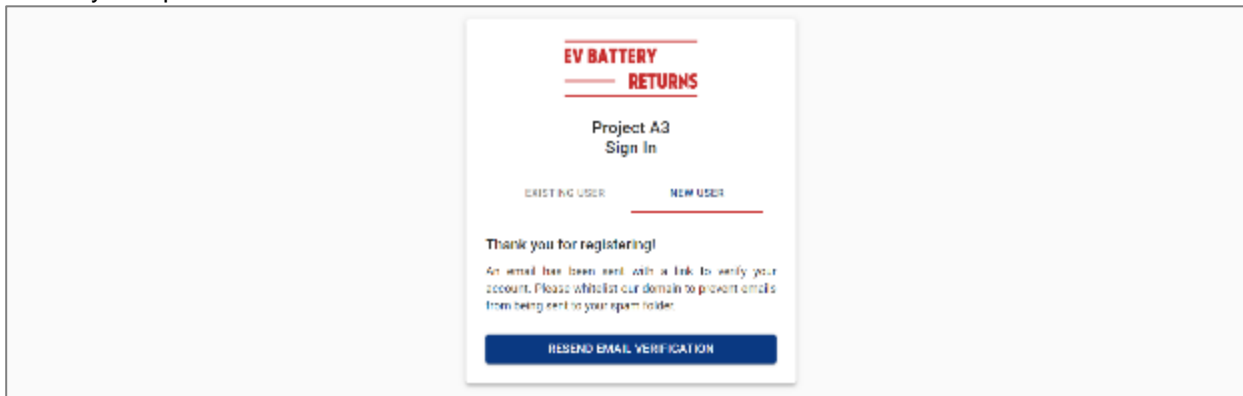

## Existing User Sign In

1. Navigate to the A3 Battery Recall Portal: <https://a3.evbatteryreturns.com/>

2. On the Sign In screen, ensure the Existing User tab is selected:

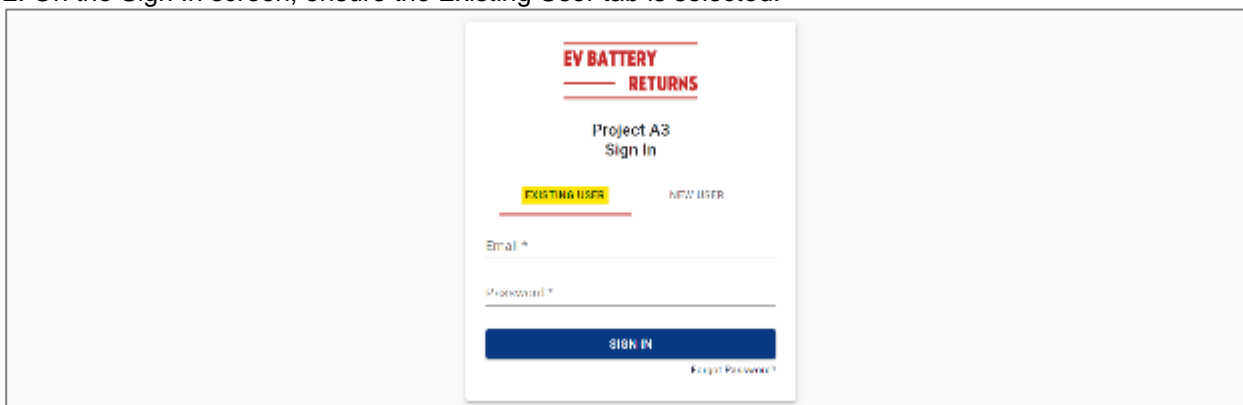

3. Enter the Email and Password used when registering your account and click the Sign In button.

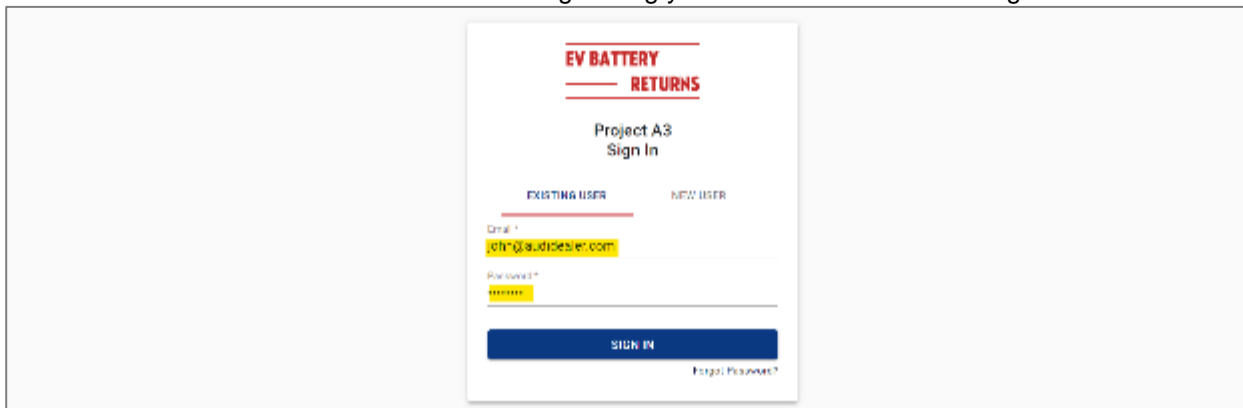

4a. [OPTIONAL] If you cannot remember your password, click the 'Forgot Password?' link.

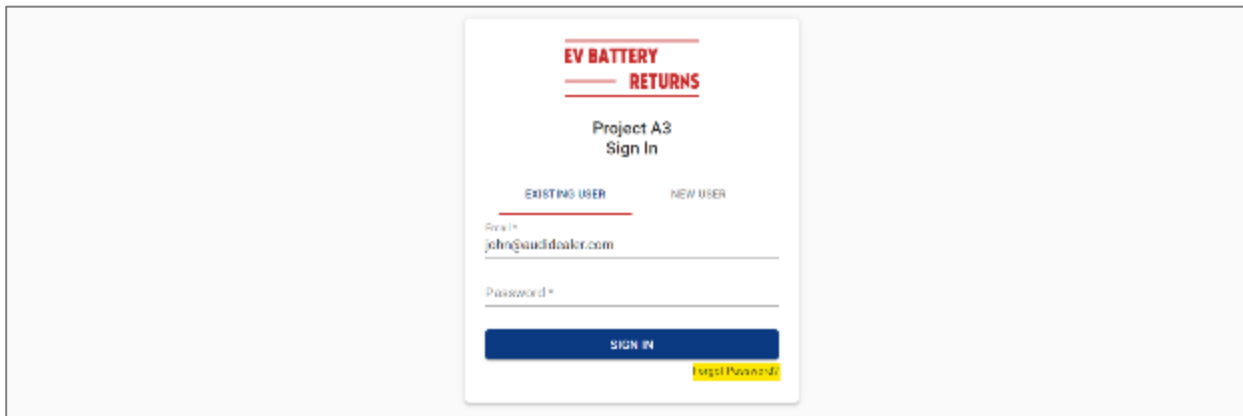

4b. [OPTIONAL] Ensure your email is entered correctly and click the Reset Password button to send an email with a link to reset your password. Once reset, you can immediately log in with your new password.

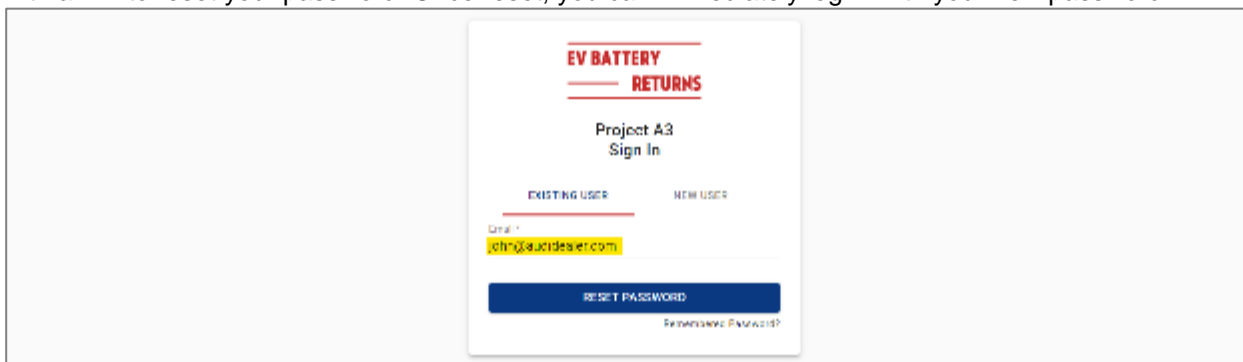

## First Portal Login (i.e. Complete Dealership Setup)

1. At first login, you will be asked to finish the setup of your dealership. Click the Complete Setup button.

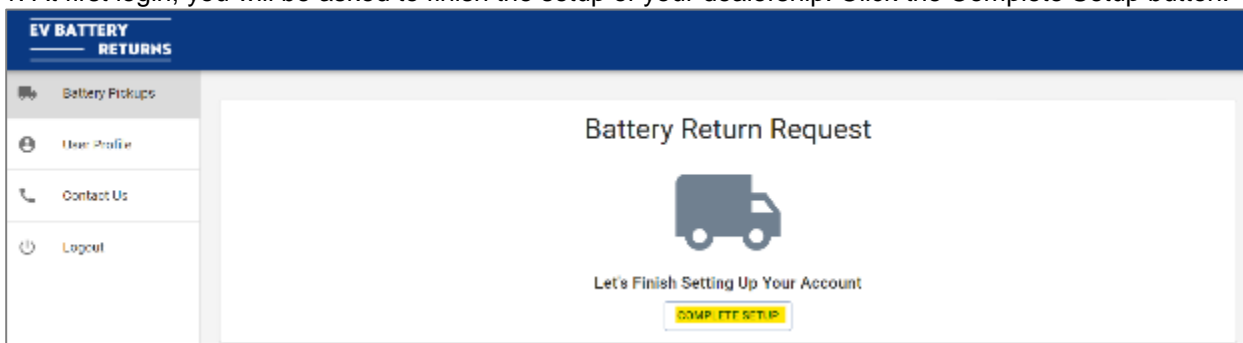

2. Enter your Dealer No. and Dealer Name into the dialog window. Click the Next button.



3. Enter the primary address from where batteries will be picked up. Click the Submit button.  
NOTE: This will set the default pickup address, however, it can be changed at any time.

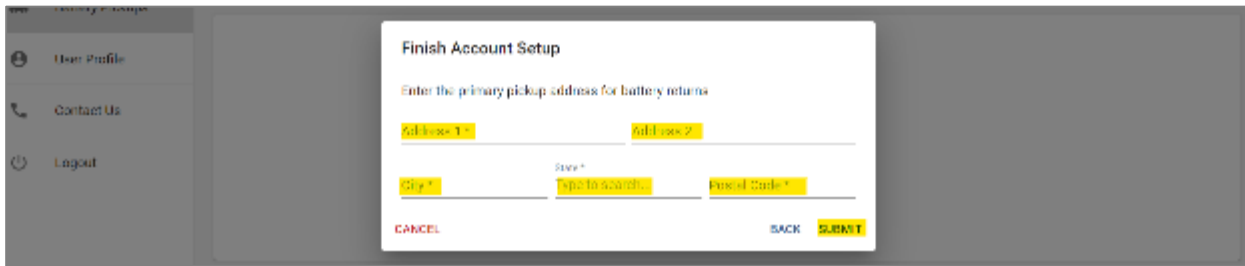

## Schedule Battery Return Request

1. From the Battery Returns view, click the Schedule Return button.

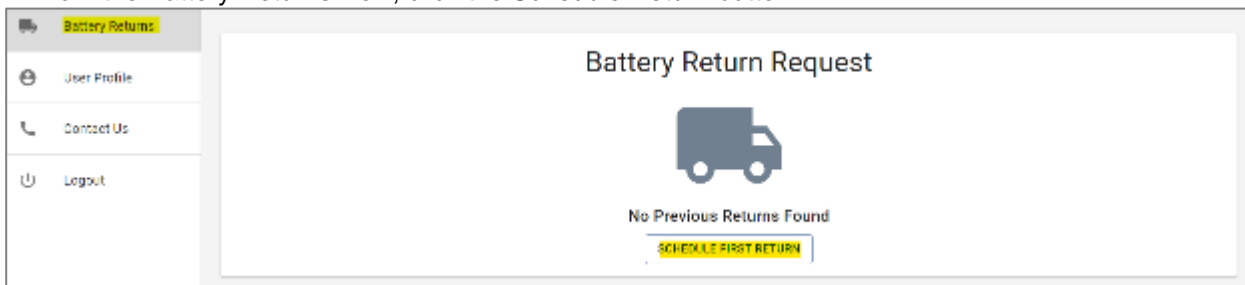

2. A dialog will be displayed. Confirm the Pickup Address either by selecting an existing address or entering a new address. Click the Next button.

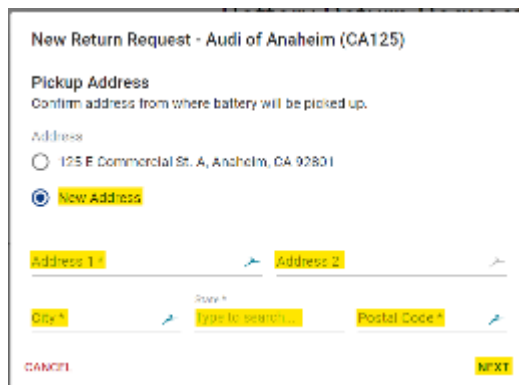
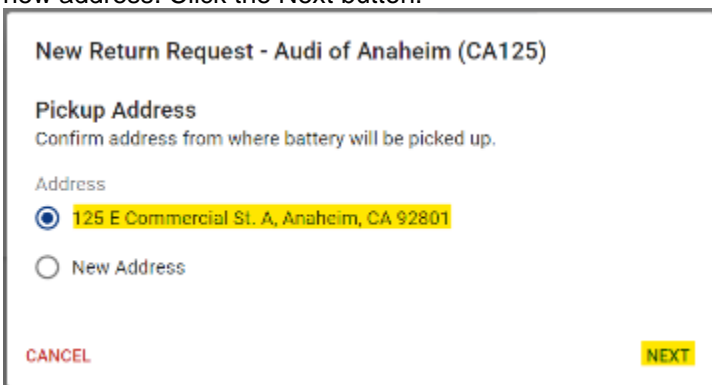

3. Confirm Contact Information for person responsible for managing the battery return. NOTE: Your user information will be added by default; but fields can be updated to a more appropriate contact person if necessary. Click the Next button.

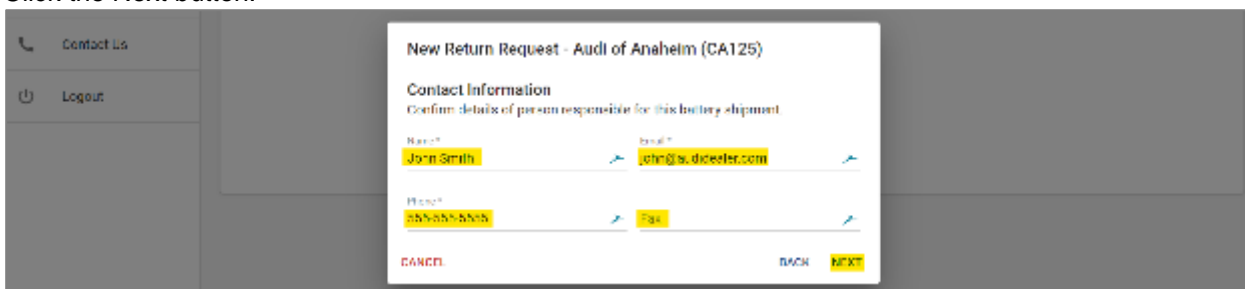

4. Enter the VIN associated with the battery being returned and select the number of defective battery modules identified (between 1 – 4 modules). Review the list of potential hazards related to the battery and select any that apply. NOTE: In most cases, no hazards will be selected; however, if you are unsure about this selection you should contact our support team at [a3-support@evbatteryreturns.com](mailto:a3-support@evbatteryreturns.com).

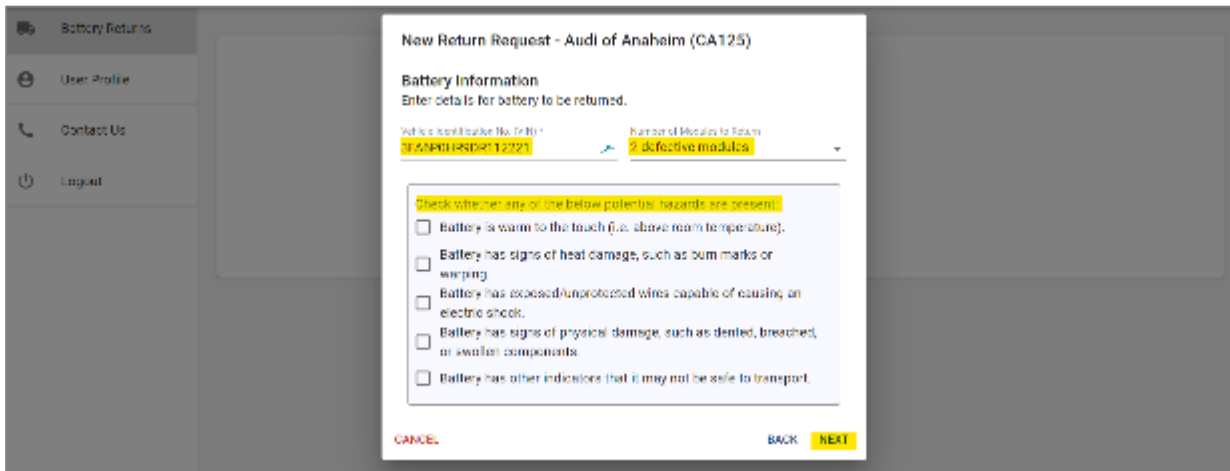

5. Read the notification about Department of Transportation training requirements and certify whether the employee responsible for packaging and offering battery for shipment is approved to ship hazardous materials. Click the Get Estimate button. NOTE: If you select “No hazmat trained employee. Use an authorized third party instead.”, all costs related to the use of that third party (approximately \$700 – \$1,400) will be passed through to your dealership.

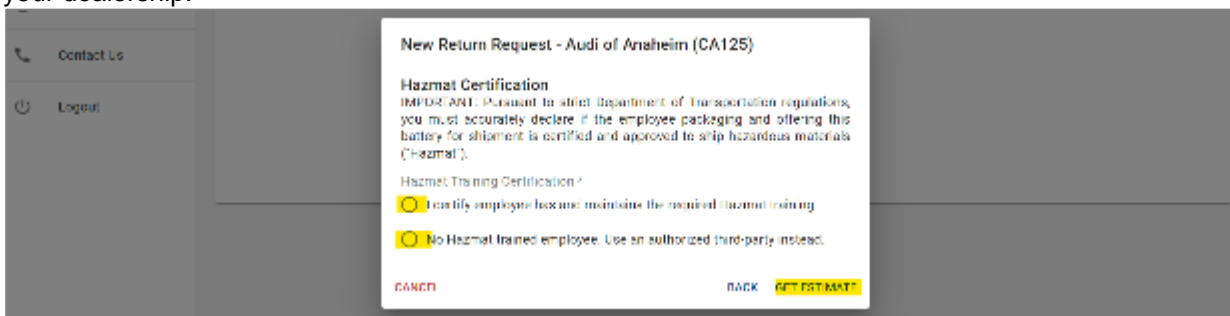

6. Review Cost Estimate charges. Select the checkbox to signify your agreement with the payment Terms and Conditions. Click Submit Request.

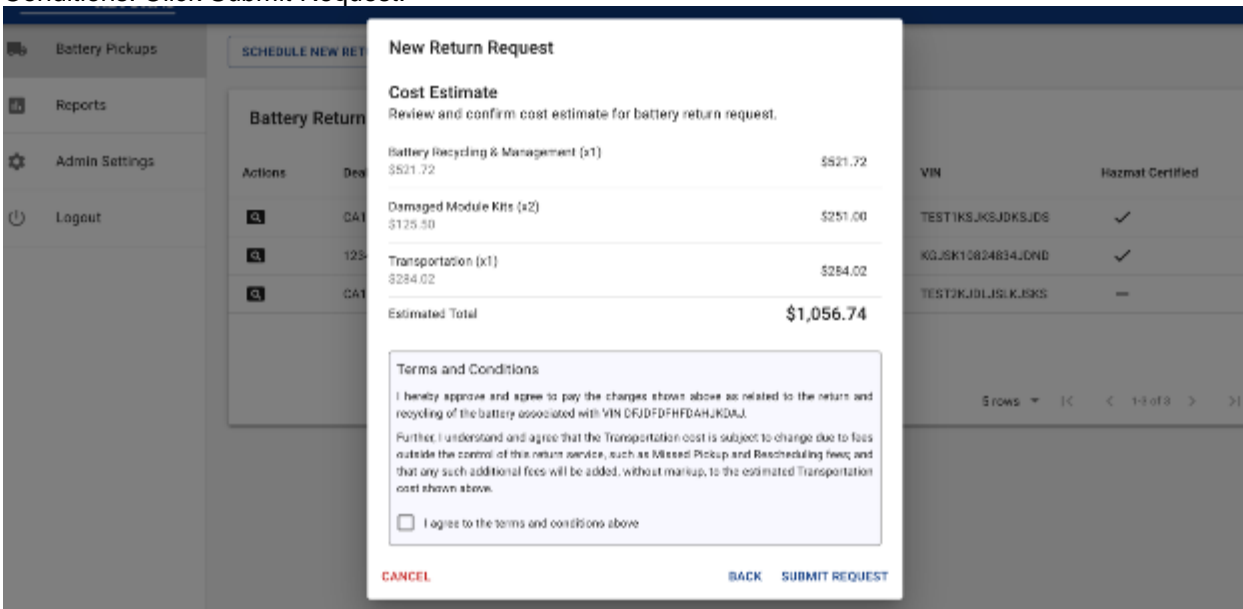

7. A table of Battery Return Requests will now be displayed. You may click on the View icon to see more details for the request. Further, you may click the Schedule New Return button to submit an additional request.

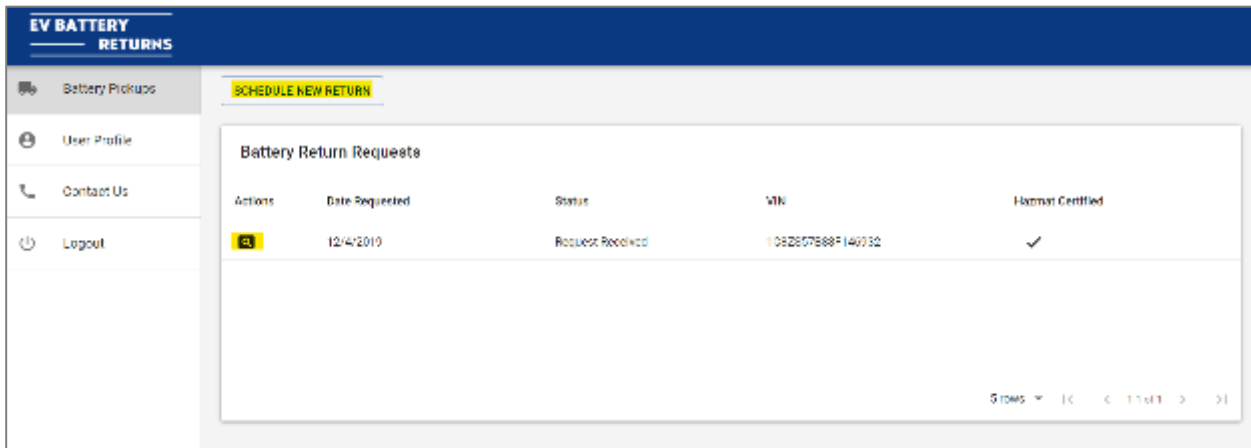

## Update User Information

1. From any screen, click the User Profile option.

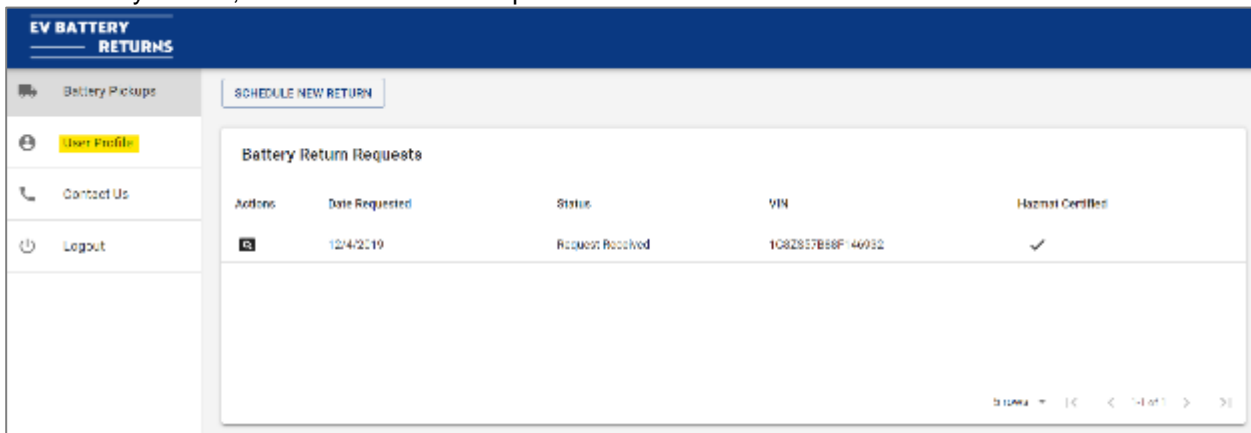

2. From this screen, you can update User, Dealer, or Dealer Locations information.