

**TECHNICAL INSTRUCTIONS**  
**FOR**  
**SPECIAL SERVICE CAMPAIGN 19LC05**

**OIL COOLER PIPE**

**CERTAIN 2016 – 2019 RX 450h**

The repair quality of covered vehicles is extremely important to Lexus. All dealership technicians performing this recall are required to successfully complete the most current version of the E-Learning course “Safety Recall and Service Campaign Essentials”. To ensure that all vehicles have the repair performed correctly; technicians performing this recall repair are required to currently hold at least one of the following certification levels:

- Certified
- Senior
- Master

It is the dealership’s responsibility to select technicians with the above certification level or greater to perform this recall repair. Carefully review your resources, the technician skill level, and ability before assigning technicians to this repair. It is important to consider technician days off and vacation schedules to ensure there are properly trained technicians available to perform this repair at all times.

## I. OPERATION FLOW CHART

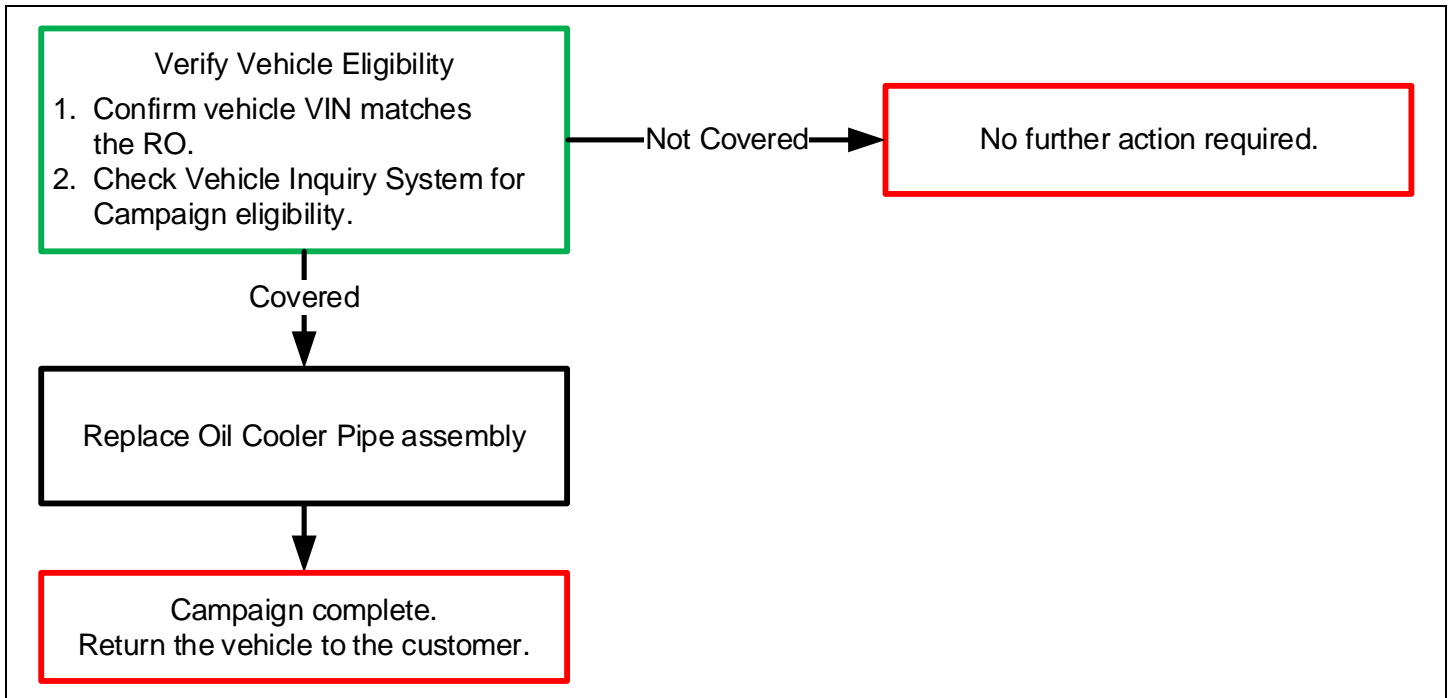

## II. IDENTIFICATION OF AFFECTED VEHICLES

### 1. CHECK VEHICLE FOR CAMPAIGN ELIGIBILITY

- a. Compare the vehicles VIN to the VIN listed on the Repair Order to ensure they match.
- b. Check the TIS Vehicle Inquiry System to confirm the VIN is involved in this Campaign, and that it has not already been completed.

**Note: TMNA warranty will not reimburse dealers for repairs completed on vehicles that are not affected or were previously completed, even by another dealer.**

## III. PREPARATION

### A. PARTS

Part Number	Part Description	Quantity
04009-40131	Pipe Kit, Oil Cooler*	1
<u>*The kit above includes the following parts:</u>		
Part Number	Part Description	Quantity
15757-31031	Oil Cooler Pipe	1
11496-31020	Gasket, Oil Hole Cover	1
15785-31040	Gasket, Oil Cooler	1

**Note: The Warranty system will only reimburse the dealer for the price of the Oil Cooler Pipe Kit. Warranty will not reimburse the dealer for individual parts.**

### B. TOOLS & EQUIPMENT

- Standard Hand Tools
- Torque Wrench
- E8 Torx socket

### C. MATERIALS

- Engine Oil 0W-20 (ILSAC GF-5)

#### IV. BACKGROUND

The involved vehicles are equipped with an engine oil cooling system. The oil cooling system could experience a small leak due to a manufacturing issue. If a vehicle is continuously operated with this condition, it may result in abnormal engine noise, illumination of the Malfunction Indicator Light (MIL), and an engine oil level low message. Over time, an oil pressure warning message may be displayed on the multi-information display and/or a buzzer may sound.

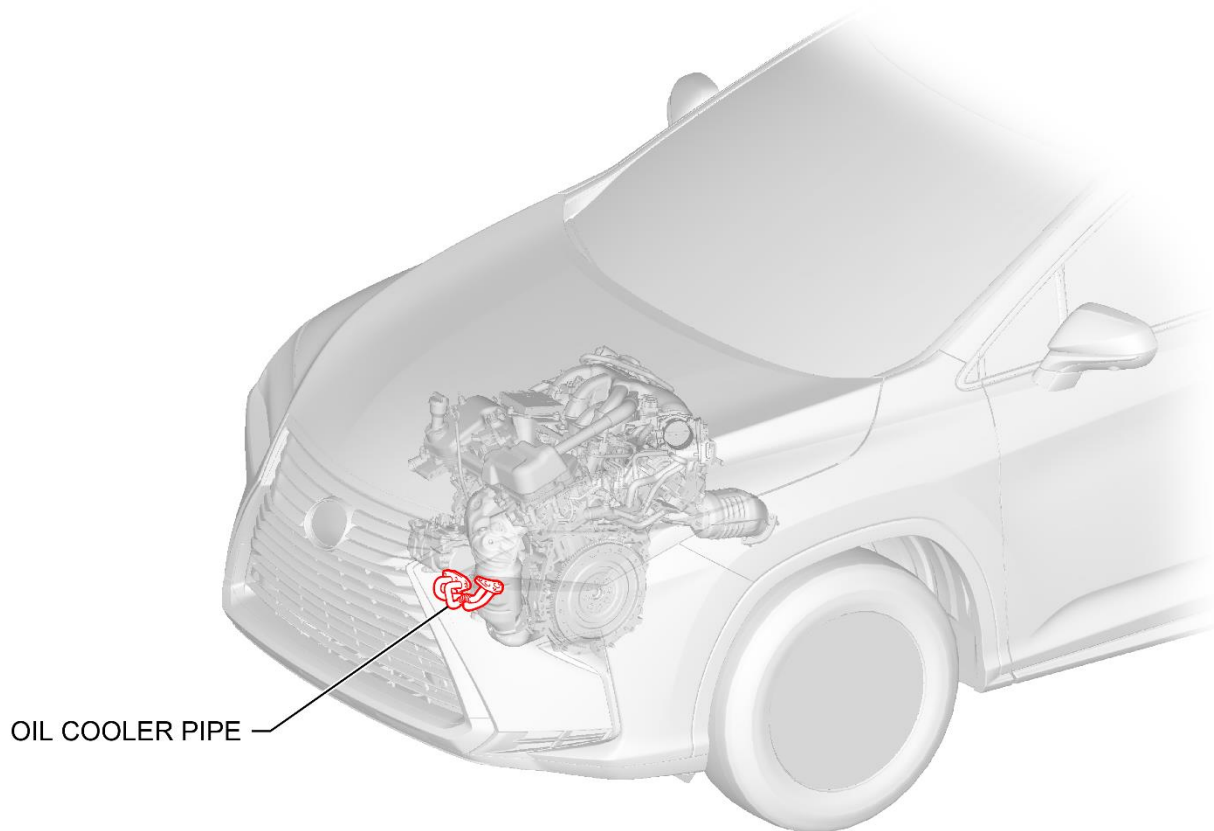

S41021aS

# V. COMPONENTS

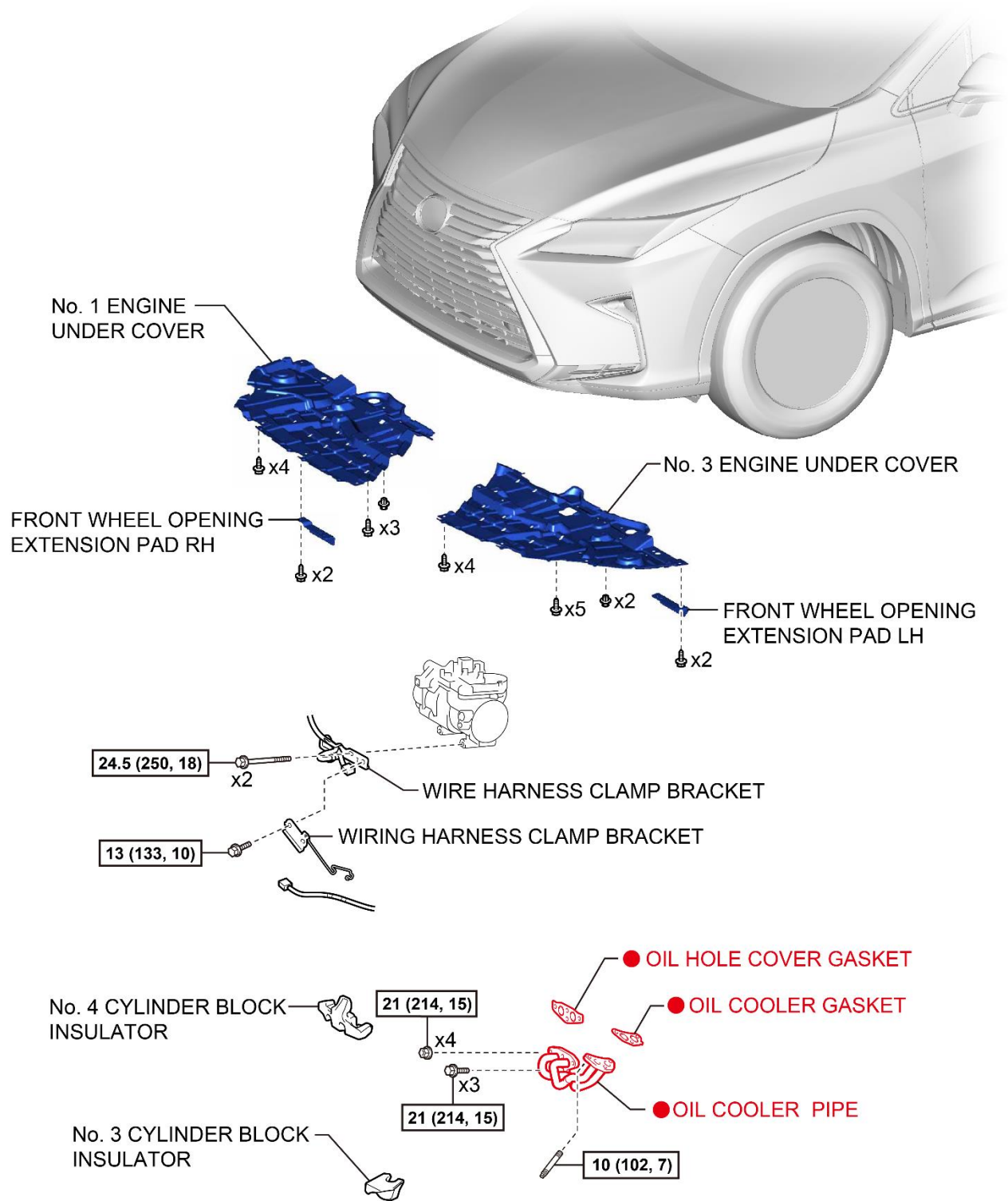

●: Component to be replaced

N\*m (kgf\*cm, ft.\*lbf) : Specified torque

## VI. DISASSEMBLY

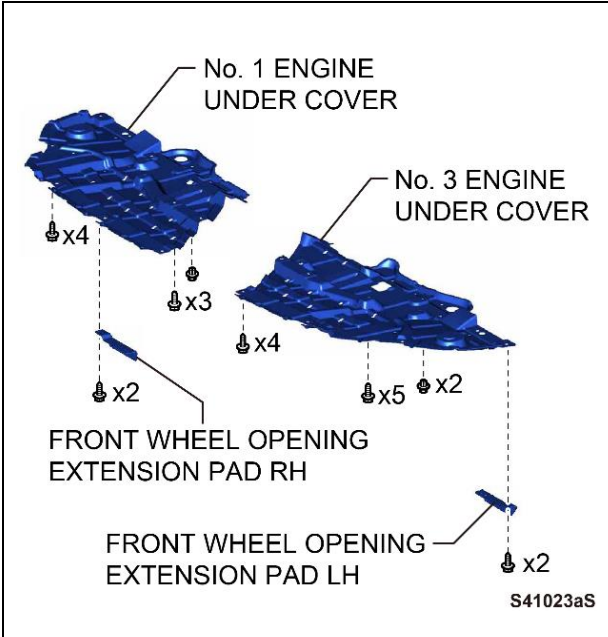

### 1. REMOVE ENGINE UNDER COVERS

- Remove the wheel opening extension pad RH.
- Remove the wheel opening extension pad LH.
- Remove No. 1 Engine Under Cover.
- Remove No. 3 Engine Under Cover.

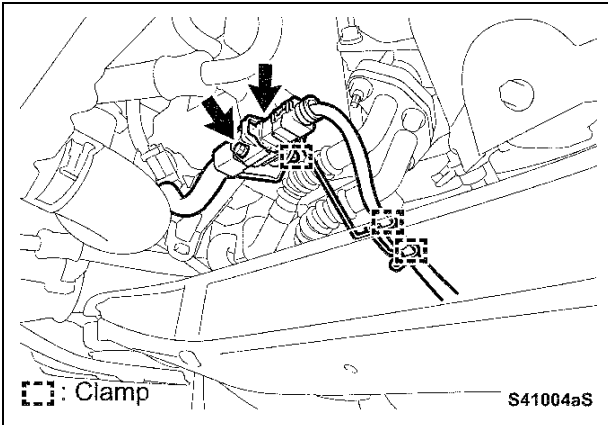

### 2. REMOVE WIRING HARNESS BRACKET

- Disconnect the connector.
- Disengage the 3 wiring harness clamps.
- Remove the bolt, and remove the wiring harness clamp bracket.

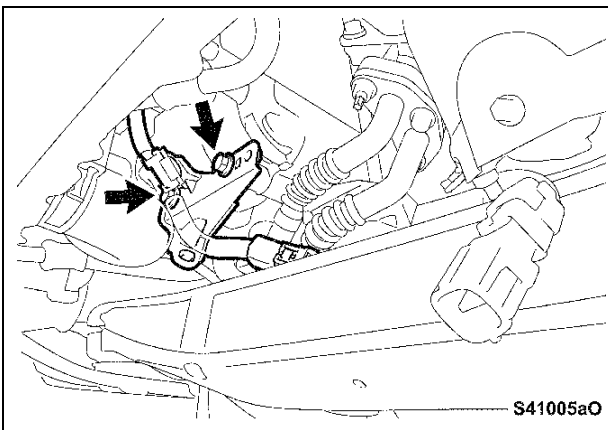

- Remove the 2 bolts and bracket.

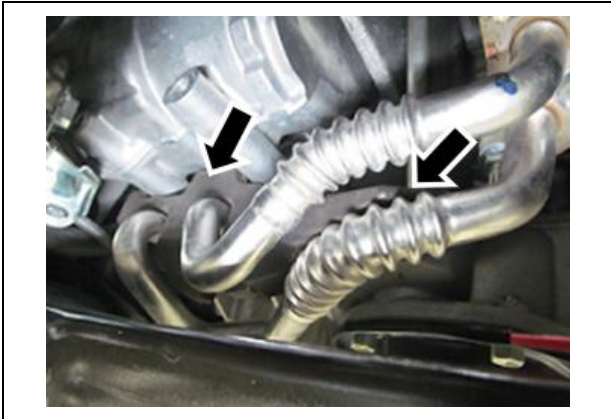

3. **REMOVE FOAM INSULATORS**
  - a. Remove the 2 block insulators.

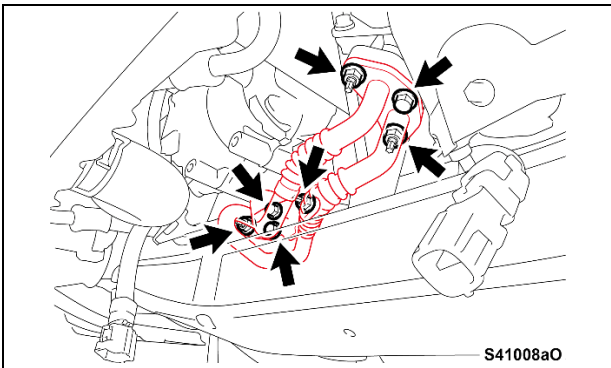

4. **REMOVE OIL COOLER PIPE**
  - a. Remove the 3 bolts and 4 nuts.

**Note:** Engine oil will leak from the flanges as the nuts/bolts are loosened.

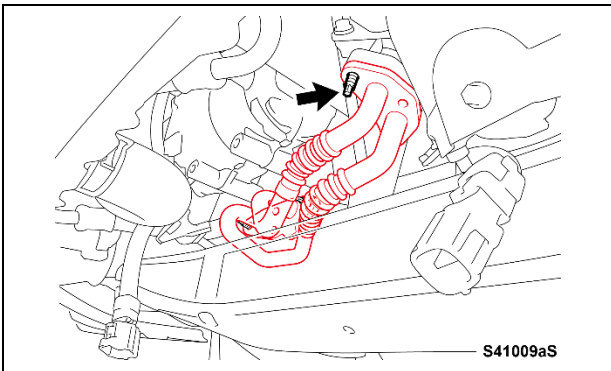

- b. Using a E8 Torx socket, remove the stud bolt.
  - c. Remove the Oil Cooler Pipe.

## VII. REASSEMBLY

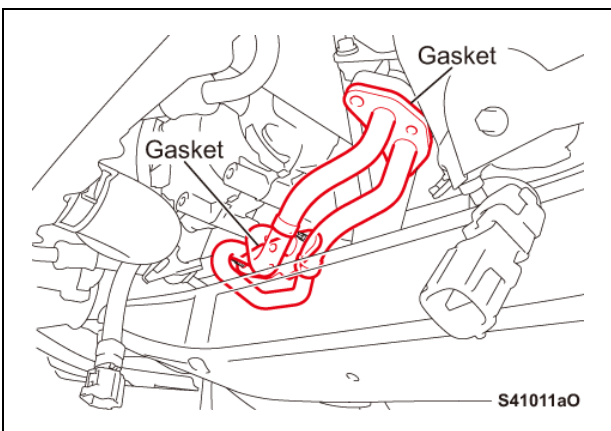

1. **INSTALL *NEW* OIL COOLER PIPE**
  - a. Clean the gasket surfaces on both the oil cooler assembly and the engine oil pan.
  - b. Temporarily install the *NEW* Oil Cooler Pipe using 2 *NEW* gaskets.

**Note:** The gaskets can be installed in any orientation.

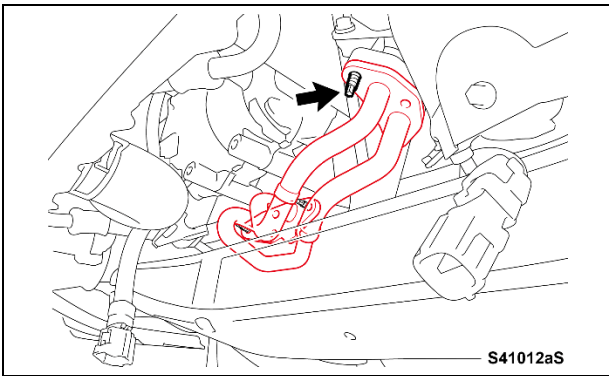

- c. Reinstall the stud bolt using an E8 Torx socket.  
**Torque: 10.0 N·m (102 kgf·cm, 84 in.lbs)**

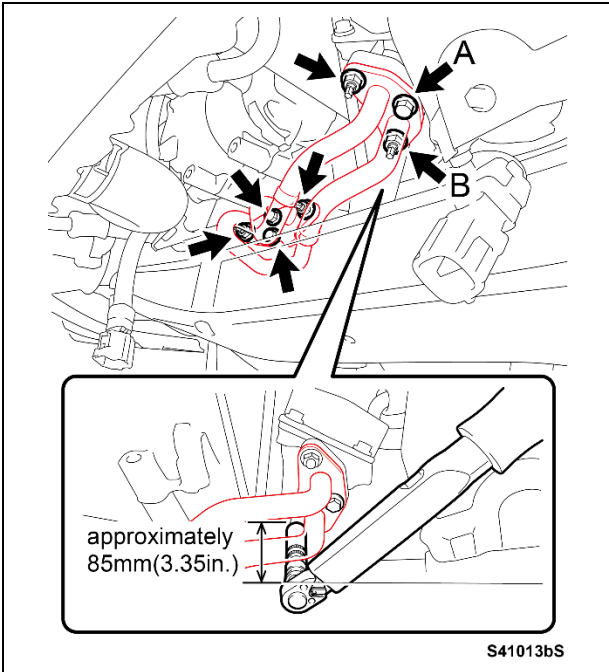

- d. Install the 3 bolts and 4 nuts.  
**Torque: 21 N·m (214 kgf·cm, 15 ft.lbs)**

**Note:** When tightening bolt A and nut B, be sure to use a torque wrench with a total length of approximately 85 mm (3.35 in.), combining the torque wrench with a deep socket wrench, extension bar, etc.

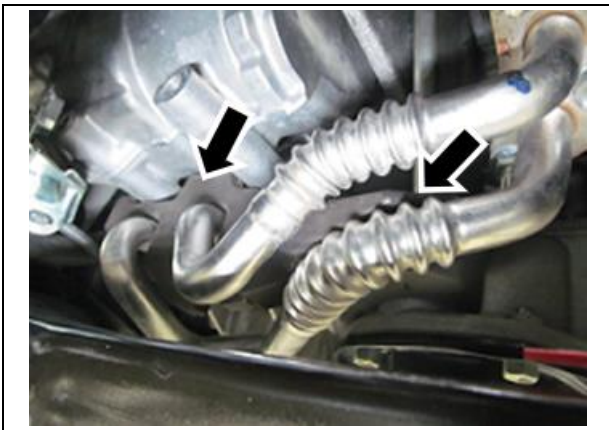

- 2. **INSTALL FOAM INSULATORS**
  - a. Reinstall the 2 foam insulators.

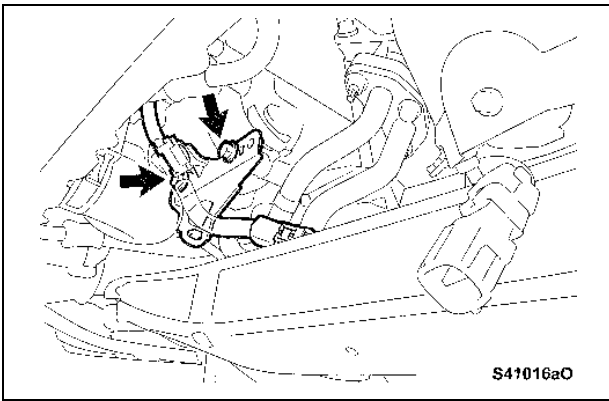

**3. INSTALL WIRING HARNESS BRACKET**

- a. Install the bracket with the 2 bolts.

**Torque: 24.5 N·m (250 kgf·cm, 18 ft.lbs)**

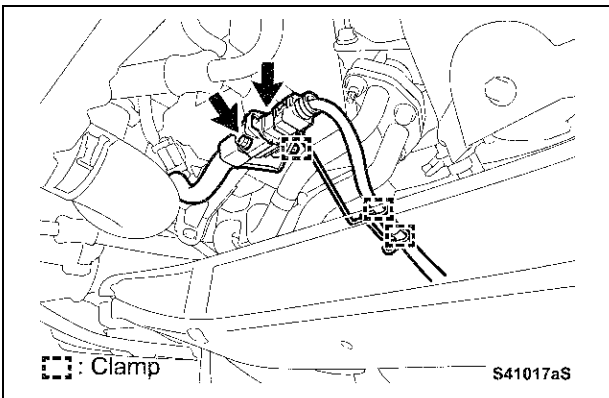

- b. Install the wiring harness clamp bracket with the bolt.

**Torque: 13 N·m (133 kgf·cm, 120 in.lbs)**

- c. Engage the 3 wiring harness clamps.  
d. Connect the connector.

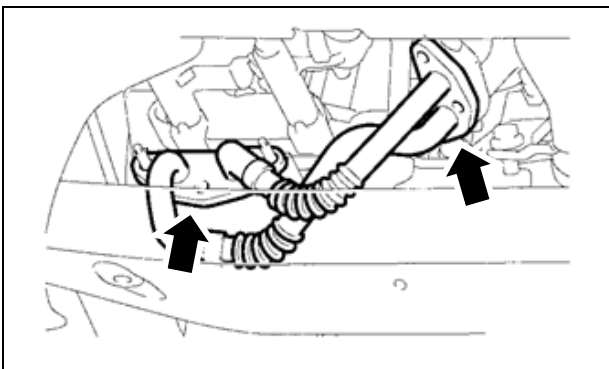

**4. INSPECT FOR OIL LEAKS**

- a. Start engine.  
b. Inspect for oil leaks at the two Oil Cooler Pipe flanges. Correct as necessary.  
c. Add engine oil as necessary to restore correct level.

**5. INSTALL ENGINE UNDER COVERS**

- a. Remove No. 1 Engine Under Cover.  
b. Remove No. 3 Engine Under Cover.  
c. Remove the wheel opening extension pad RH.  
d. Remove the wheel opening extension pad LH.

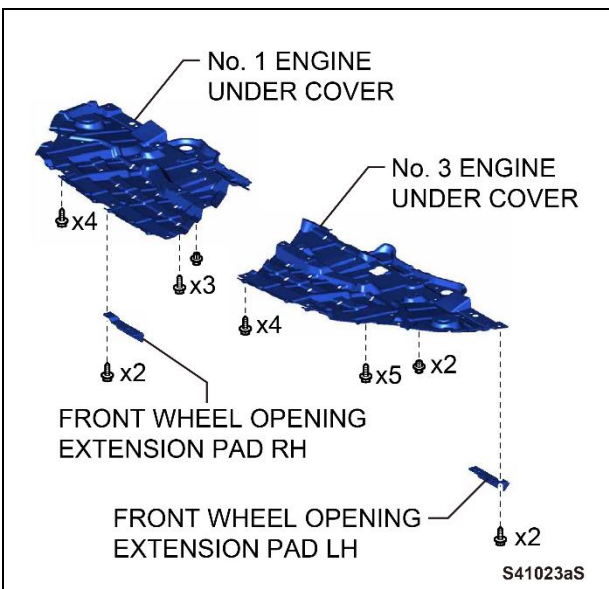



## ◀ VERIFY REPAIR QUALITY ▶

- Confirm there are no oil leaks.
- Confirm the oil level is at the correct level.

If you have any questions regarding this update, please contact your area representative.

### 10. APPENDIX

#### A. PARTS DISPOSAL

As required by Federal Regulations, please make sure all recalled parts (original parts) removed from the vehicle are disposed of in a manner in which they will not be reused, **unless requested for parts recovery return.**

#### B. CAMPAIGN DESIGNATION DECORDER

