



WARRANTY BULLETIN

WARRANTY CAMPAIGN

CAUTION: All involved customers must be notified, all involved units must be corrected as per instruction herein.

Campaign no.: 2020-0005

February 18, 2020

Subject: **Spyder® RT - Abnormal Gaps Around the Rear Cargo Module Access Covers**

No. **2020-3**

MODEL YEAR	MODEL	ADMISSIBLE UNITS
2020	Spyder RT	Go to BOSSWeb/Warranty/Campaign Monitoring to know the quantity of units in your inventory impacted by this campaign
<p>IMPORTANT</p> <ul style="list-style-type: none"> – When a vehicle comes in for service, always type the VIN in Knowledge Center to check for pending campaigns or alerts. – When performing any work on a vehicle, it is good practice to connect it to BUDS2 to ensure that all needed updates are done. 		

PROBLEM

Spyder RT manufactured until February 5th may show some fit and finish issues.

The interference between access covers and frame prevent mounting holes alignment. This situation creates abnormal gaps around both rear cargo module access covers.

Abnormal gaps are present between both rear cargo module access covers and adjacent body parts.

To minimize the gaps, only the access cover rear screw was installed from factory.

The front was intentionally secured with a locking tie instead of a screw.

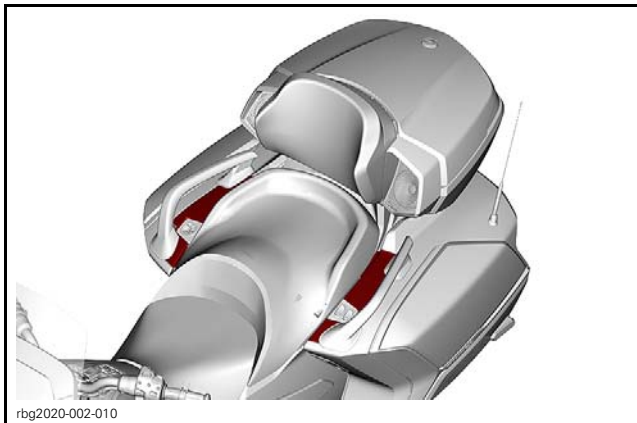

1. Locking tie

Where Finding the Production Date

In Knowledge Center:

- Enter the VIN
- Go to *PRODUCT HISTORY*
- At the bottom of this box, select *VIEW COMPLETE PRODUCT HISTORY*
- Check the date beside *VEHICLE CREATION*.

SOLUTION

Replace both access covers and install screws instead of the locking ties.

PARTS REQUIRED

Parts will be available by April 30th.

Order parts through regular channel.

DESCRIPTION	PART NUMBER	QTY
Left access cover	708303754	1
Right access cover	708303755	1
K50 x 16 Torx screw	250000720	2

CORRECTIVE ACTION

IMPORTANT

This procedure must be performed only when parts will be available.

1. Remove the passenger seat.
2. Cut the locking tie securing the front of the access cover.
3. Remove and keep the rear screw.
4. Remove and discard the access cover.
5. Turn the new access cover upside down.
6. Using a 5mm drill bit, drill a hole on the front tab, under the front slotted hole.

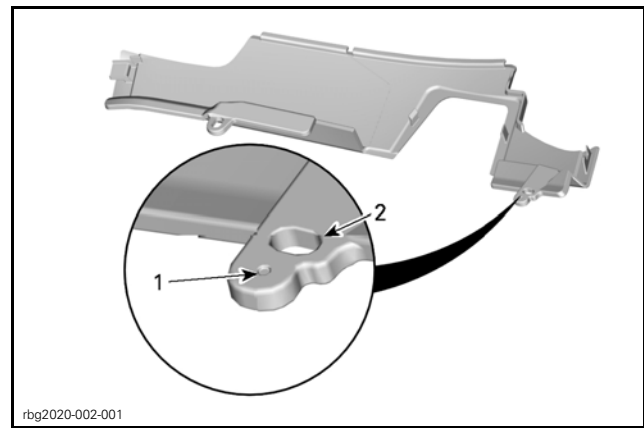

rbg2020-002-001

1. Molded dot where drill
2. Front slotted hole

7. Position the access cover and loosely install the previously removed screw and a new K50 x 16 Torx screw.
8. Move the access cover to have an equal gap in back and in front.
9. Hold the access cover in this position and tighten screws.

TIGHTENING TOQUE	
Access cover screws	2.75 N•m ± 0.25 N•m (24 lbf•in ± 2 lbf•in)

10. On the other side of the vehicle, repeat steps 2 to 9.
11. Reinstall the passenger seat.

WARRANTY

Submit a warranty claim using the following information.

For claiming procedure, refer to the *DEALER/DISTRIBUTOR WARRANTY GUIDE*.

Product Line	OnRoad
Unit Model Year	2020
Campaign/Bulletin/Description	5 / 2020-3 / Rear Access Cover Abnormal Gaps
*Action	
Inspect	Repair
<input type="checkbox"/>	<input checked="" type="checkbox"/>
Total Labor time paid	0.3 hour
Expiration date	October 31, 2021