



SIM 11 01 17

2020-01-06

## FAULT 118002 - MIXTURE TOO RICH - SETS DURING WINTER WITH COLD AMBIENT TEMPS

This Service Information Bulletin (Revision 8) replaces SI M11 01 17 **dated May 2019**.

### What's New (Specific text highlighted):

- Situation (reference to winter fuel deleted)
- Model
- Procedure

## MODEL

E-Series	Model Description	Production Date	Affected Engine
F54	MINI Clubman	December 2014 thru June 2019	B36M, B46M, B48O
F55	MINI Hardtop 4 Door	October 2013 thru June 2019	B36M, B38M, B46M
F56	MINI Hardtop 2 Door	April 2013 thru July 2019	B36M, B38M, B46M, B48M, B48O,
F57	MINI Convertible	November 2014 thru June 2019	B36M, B46M, B48O
F60	MINI Countryman	November 2015 thru September 2019	B36M, B46M, B48O, XB2H

## SITUATION

The Service Engine Soon (MIL) light is on, together with the following fault stored in the Digital Motor Electronics (DME).

Fault Code:	Control Unit:	Fault Code Text:
118002	DME	Mixture control: Fuel-air mixture too rich

In the situation being described, the fault is only stored during the cold winter months.

Note: Various other causes for a rich mixture fault are possible and should not be overlooked.

## CAUSE

- DME software diagnostic is too sensitive
- This situation is most likely to occur if the driving profile is one of frequent cold engine starts and/or primarily short distance trips (idle / low load operation) where full engine operating temperature is not reached
- Due to the lower engine oil temperatures crankcase vapors that contain a higher fuel content are not completely drawn off via the crankcase ventilation system

A false DME adaptation routine could then lead to this fault being set.

## CORRECTION

1. Check for rich mixture condition.
2. Program the vehicle with ISTA Next.
3. Replace the engine oil.
4. Inspect cylinder head cover and replace as needed.
5. Perform the Quality Certification I (QC1) on a new vehicle.

## PROCEDURE

Do not replace any parts unless a definite failure is identified during diagnosis.

Perform diagnosis using the latest version of ISTA Next.

### 1. Check the current mixture adaptation:

Path: ECU function - DME / Diagnostic scan / 721 Mixture Adaptation

Note: Let the engine idle at operating temperature. If the mixture adaptation drops significantly below 1.0, it indicates a rich mixture condition.

### 2. Replace the engine oil and filter on a warm engine.

Refer to **SI M11 01 15**: Engine Oil Quick Reference and Drain Plug Torque

Do not reset the Condition Based Service (CBS) for engine oil service unless the oil service shows to be currently recommended or due on the key reader.

### 3. Upgrade the vehicle software using ISTA Next to the appropriate level shown below:

Programming is only required if the integration level is earlier/lower than the target level.

All except vehicles equipped with the XB2H engine:

Model	Target
F54 (Cooper Clubman)	<b>F056-19-03-540</b> or higher
F55 (Cooper Hardtop 4 door)	
F56 (Cooper Hardtop 2 door)	
F57 (Cooper Convertible)	
F60 (Cooper Countryman)	

Vehicles equipped with the XB2H engine.

Model	Target
F60 PHEV (MINI Cooper S E Countryman ALL4)	<b>F056-19-11-510</b> or higher

Note that ISTA Next will automatically reprogram and code all programmable control modules that do not have the latest software.

**Always connect a MINI-approved battery charger/power supply (SI M04 08 09).**

For information on programming and coding with ISTA, refer to CenterNet / TIS / Technical Documentation / Programming and Diagnostics / Programming Documentation.

Only for vehicles equipped with the B36 and B38 engine produced to October 31, 2015:

### 4. Inspect the version of the cylinder head cover.

Older version shown.

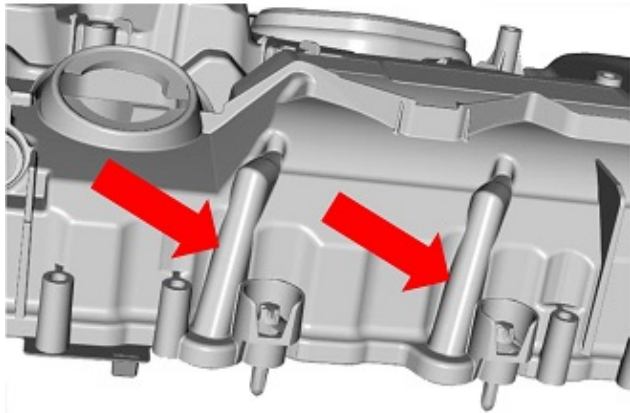

GRUSB1118-31

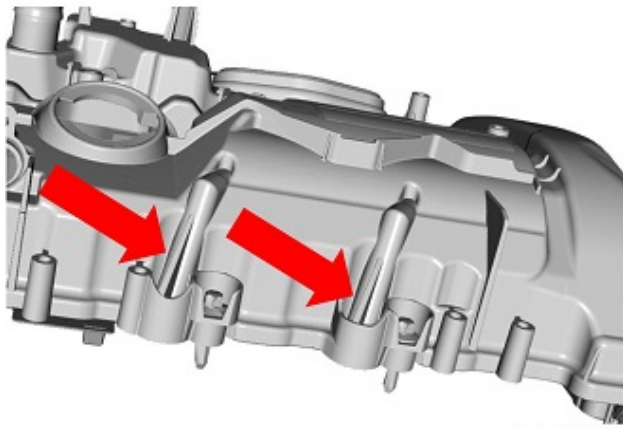

GRUSB1118-32

Newer version shown.

Note: This updated version can be identified by the additional supports on crankcase ventilation ports (arrows).

Replace the cylinder head cover and profile gasket if the older version is equipped.

Note: Additional information may be found in FUB-HIL-HI-0009-A17 - Versions of the cylinder head cover, and in **M11 03 15**.

Only for vehicles which have not yet received the QC1 described in the model list above:

5. During the cold season, replace the engine oil as described in step #2 prior to delivering the vehicle to the customer.

**PARTS INFORMATION**

Obtain and confirm the part numbers for your specific vehicle by entering the chassis number in ETK/AIR which takes into account specific equipment and/or options.

Part Number	Description	Quantity
11 42 8 570 590	Oil filter	1
83 21 2 365 955	MINI Original Engine Oil LL14FE+ 0W-20 (fully synthetic)	B36/B38 – 4.25 liters Or B46/B48 – 5.5 liters
Refer to ETK	Cylinder Head Cover	1

**WARRANTY INFORMATION**

Defect Code: 10 42 90 01 00 Fx B36 B38 B46 B48 Fault memory mixture control

Refer to the Attachment for Warranty Information. The section below is also included in the Warranty Attachment, but is duplicated here to enable use of the SIB link.

**Note:** Only claim the engine oil and filter change as stated above when **SI M01 02 15** (CBS Engine Oil Service Task: New MINI Vehicles in Inventory/in Stock) does not apply or when the engine oil service does not show Recommended or Due.

Supporting Materials

[picture\\_as\\_pdf M110117 Attachment Warranty Information.pdf](#)

## FAULT 118002 - MIXTURE TOO RICH SETS DURING WINTER WITH COLD AMBIENT TEMPERATURES

### WARRANTY INFORMATION

The following repair is covered under the terms of the MINI New Passenger Car Limited Warranty.

<b>Defect Code:</b>	<b>10 42 90 01 00</b>	<b>Fx B36 B38 B46 B48 Fault memory mixture control</b>
---------------------	-----------------------	--------------------------------------------------------

#### Dealers that experience Cold Winter Months

- **New vehicles in-stock only (No in-service date), just prior to the first delivery, fault code 118002 is not set/stored in the DME**

<b>Labor Operation:</b>	<b>Labor Allowance:</b>	<b>Description:</b>
11 99 000	3 FRU (All except the F57); 4 FRU (F57)	Work time to change the engine oil and filter <b>without</b> a CBS data reset

**Note:** Only claim the engine oil and filter change as stated above when SI **M01 02 15** (CBS Engine Oil Service Task: New MINI Vehicles in Inventory/in Stock) does not apply.

Or:

#### All applicable vehicles that have fault code 118002 set/stored in the DME-

<b>Labor Operation:</b>	<b>Labor Allowance:</b>	<b>Description:</b>
00 00 006	Refer to AIR	Performing vehicle test (with vehicle diagnosis system – checking faults) (Main work)
Or:		
00 00 556	Refer to AIR	Performing vehicle test (with vehicle diagnosis system – checking faults) (Plus work)
And:		
61 21 528*	Refer to AIR	Connect an approved battery charger/power supply (indicated in AIR as Charging battery)

If you are using a Main labor code for another repair, use the Plus code labor operation 00 00 556 instead of 00 00 006.

\*Claim 61 21 528 only when it is not included in another flat rate labor operation.

And, additionally for the:

#### e-Vehicle

<b>Labor Operation:</b>	<b>Labor Allowance:</b>	<b>Description:</b>
61 25 910	Refer to AIR	Recharging high-voltage battery unit (to high voltage charging socket)

And, only if the:

**Vehicle's I-level is lower than 18-07-500-**

<b>Labor Operation:</b>	<b>Labor Allowance:</b>	<b>Description:</b>
61 00 730	Refer to AIR	Programming/encoding control unit(s)

And, if applicable:

For MINI vehicles equipped with the B36 and B38 engine produced to October 31, 2015 only

<b>Labor Operation:</b>	<b>Labor Allowance:</b>	<b>Description:</b>
11 12 510	Refer to AIR	<b>Replacing</b> cylinder head cover

And, together with the items above that apply:

<b>Labor Operation:</b>	<b>Labor Allowance:</b>	<b>Description:</b>
11 99 000	3 FRU (All except the F57); 4 FRU (F57)	Work time to change the engine oil and filter <b>without</b> a CBS data reset

**Note:** Only claim the engine oil and filter change as stated above when SI **M01 02 15** (CBS Engine Oil Service Task: New MINI Vehicles in Inventory/in Stock) does not apply or when the engine oil service does not show Recommended or Due.

Refer to AIR for the corresponding flat rate unit (FRU) allowances.

Work time labor operation code 11 99 000 is not considered a Main labor operation. Also, since the work time FRU allowance to be claimed is specified, a separate punch time is not required. However, it still requires an explanation on the repair order and in the claim comments section.

And:

**Sublet – Bulk Materials**

Sublet Code 4	See sublet reimbursement calculation below	Reimbursement for used quantities of required operating fluids, including engine oil only when it is not claimed under the MINI Maintenance Program (applicable MINI part numbers). Please do not use these part numbers for claim submission.
---------------	--------------------------------------------	------------------------------------------------------------------------------------------------------------------------------------------------------------------------------------------------------------------------------------------------

Sublet reimbursement calculation for claiming the used quantity applicable repair-related bulk materials (MINI part numbers) is at the dealer net price plus your dealer's handling.

Enter this material cost in sublet and itemize the amount on the repair order and in claim comment section.

**Programming and Encoding - Vehicle Control Units**

During the same workshop visit, **if a vehicle also requires another Technical Campaign or repair that also includes programming and encoding the control units, the programming procedure may only be invoiced one time.**

- A. **The programming procedure** automatically reprograms and encodes all vehicle control modules which do not have the latest software i-level. If one or more control module failures occur during this programming procedure:

- Please claim this consequential control module-related repair work under the defect code listed in this bulletin with the applicable AIR labor operations.

Please explain this additional work (The why and what) on the repair order and in the claim comments section.

B. For control module failures that occurred prior to performing this programming procedure:

- When covered under an applicable limited warranty, claim this control module-related repair work using the applicable defect code and labor operations (including diagnosis) in AIR.

### **Overlapping Labor Procedure**

If invoicing the AIR flat rate labor operation codes for other repair work results in overlapping labor, for those flat rate labor operations that are affected, you are able to:

- Replace the stated AIR FRU allowance with a reduced FRU value to eliminate the overlapping labor.

For help in identifying the overlapping labor, please refer to the AIR FRU Plausibility Check (Overlapping Labor Tool) that is located in the AIR Client.

Eligible other repair work being claimed under a different defect code will require separate punch times.

On the repair order and in the claim comment section, please identify and itemize those labor operations being claimed with a reduced FRU value.

### **Other Repairs**

If other eligible and covered work is performed after carrying out the ISTA diagnostics and other diagnosis, claim this work with the applicable defect code and labor operations (including diagnosis) that are listed in the AIR.