

# PREVOST

## Instruction Sheet

## IS-19901A

### ELECTRIC FAN DRIVE COOLING SYSTEM CONVERSION WITH BOSCH ALTERNATOR

X3 coaches (2PCG...), X3 VIP with big A/C system (2PCB..., 2PCC...) US10 to GHG17 (B-5002 to H-6179)

REVISION : A THIS DOCUMENT SUPERSEDES PREVIOUS VERSION.

Jan 24-2020

Mention added stating to disable "Prime"

Parts added in the kit:

|          |                            |         |
|----------|----------------------------|---------|
| 053662   | TURBO DIFFUSER PIPE        | QTY: 1x |
| 21096684 | GASKET, TURBO OUTLET       | QTY:1x  |
| 20592787 | CLAMP, DIFFUSER V-BAND     | QTY:1x  |
| 506080   | BELT, DRIVE POLY V 8PK1575 | QTY: 2x |

#### **IMPORTANT NOTE**

#### **VEHICLES EQUIPPED WITH OPTIONAL PRIME ENERGY MANAGEMENT SYSTEM**

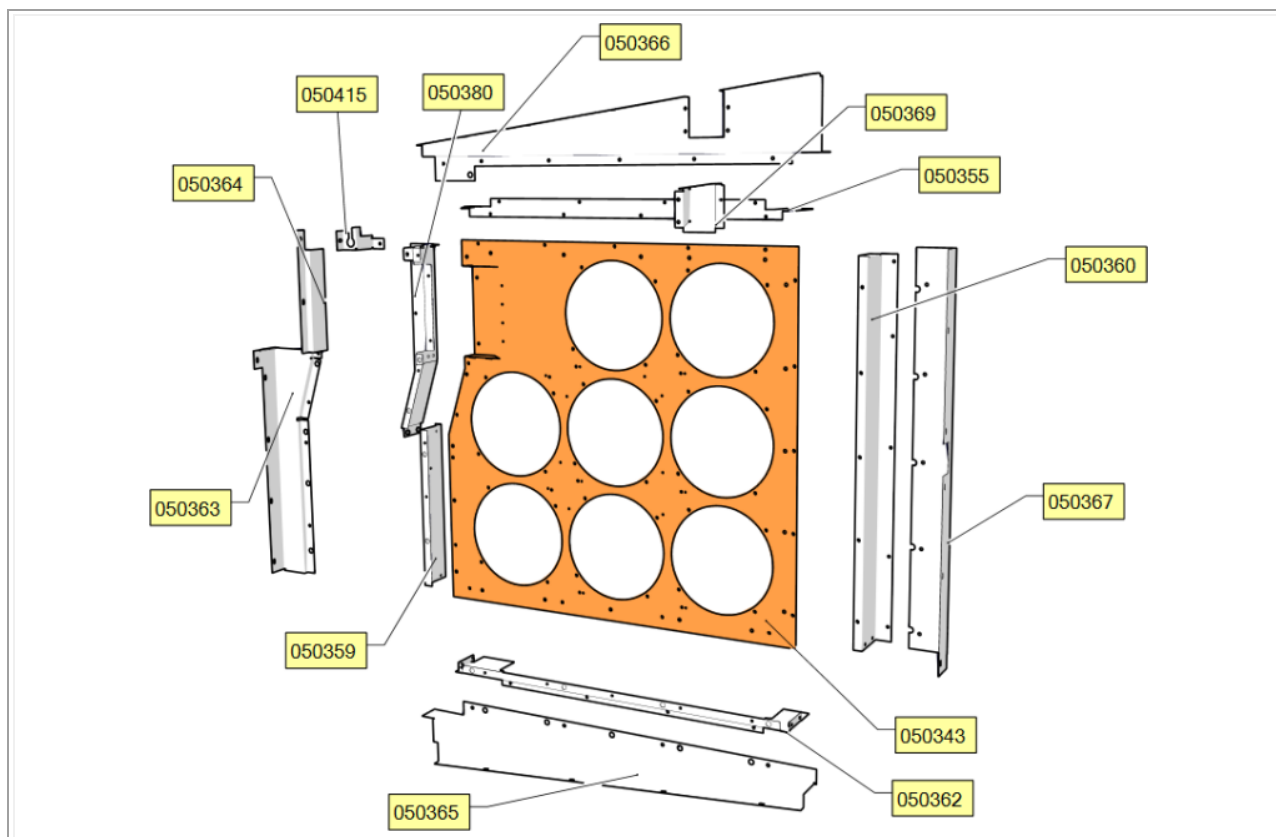
*TO PREVENT OVERLOADING THE L.H. SIDE ALTERNATOR, IT IS VERY IMPORTANT TO DISABLE « PRIME » SYSTEM ON VEHICLES RECEIVING THIS CONVERSION. PLEASE CONTACT YOUR NEAREST PREVOST SERVICE CENTER TO HAVE THE PRIME SYSTEM DISABLED. A SOFTWARE TOOL IS NEEDED TO DO SO.*



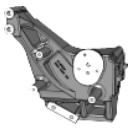
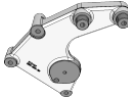


# PREVOST




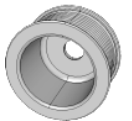




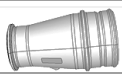

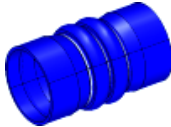
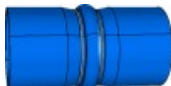


## MATERIAL









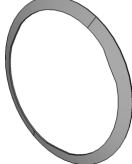

Kit **IS19901** contains the following parts:



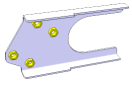
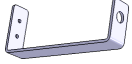

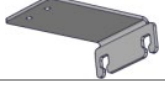
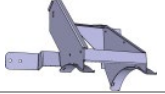


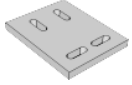




| Part No. | DESCRIPTION   |  | Qty |
|----------|---|--|-----|
| 050343   | FAN SUPPORT PANEL                                       |  | 1   |
| 050355   | UPPER SHROUD TRANSITION                                 |  | 1   |
| 050359   | LEFT SHROUD TRANSITION                                  |  | 1   |
| 050360   | RIGHT SHROUD TRANSITION                                 |  | 1   |
| 050362   | LOWER SHROUD TRANSITION                                 |  | 1   |
| 050363   | LOWER LEFT SHROUD PANEL X3 US10+                        |  | 1   |
| 050364   | UPPER LEFT SHROUD PANEL & WURTH BOX<br>SUPPORT X3 US10+ |  | 1   |
| 050365   | LOWER SHROUD PANEL X3 US10+                             |  | 1   |
| 050366   | UPPER SHROUD PANEL X3 US10+                             |  | 1   |
| 050367   | RIGHT SHROUD PANEL                                      |  | 1   |
| 050369   | PULL ROD BOX  |  | 1   |
| 050380   | UPPER LEFT SHROUD TRANSITION PANEL                      |  | 1   |
| 050415   | UPPER LEFTSHROUD PANEL                                  |  | 1   |




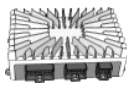
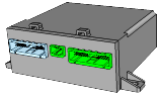
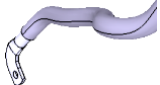

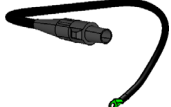

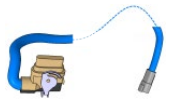




|        | MECHANICAL  |   |   |
|--------|---|---|---|
| 012349 | IDLER PULLEY  |  | 1 |
| 012941 | PULLEY, DRIVE 10 RIBS   |  | 1 |
| 012942 | L.H. ENGINE MOUNT   |  | 1 |
| 011213 | SUPPORT, IDLER + TENSIONER  |  | 1 |
| 453076 | CAP, DUST   |  | 1 |
| 506026 | 1x BELT, DRIVE POLY V 10PK1695<br>1x BELT, DRIVE POLY V 10PK1695 (for your spare kit) |  | 2 |

|              |   |   |   |
|--------------|---|---|---|
| 506080       | 1x BELT, DRIVE POLY V 8PK1575<br>1x BELT, DRIVE POLY V 8PK1575 (for your spare kit) |    | 2 |
| 510991       | TENSIONER, BELT   |    | 1 |
| 560748       | BOSCH HD10PLBH ALTERNATOR 28V-150AMP<br>J180  |    | 1 |
| 0600265      | PULLEY, ALTERNATOR 10PK, 73 DOB   |    | 1 |
| <b>PIPES</b> |   |   |   |
| 050308       | CAC OUTLET PIPE X3 US10+  |    | 1 |
| 050309       | RADIATOR INLET COOLANT PIPE X3 US10+  |    | 1 |
| 050328       | CAC INLET PIPE X3 US10+   |    | 1 |
| 050331       | RADIATOR OUTLET PIPE X3 US10+   |    | 1 |
| 053662       | TURBO DIFFUSER PIPE, STRAIGHT   |  | 1 |
| <b>HOSES</b> |   |   |   |
| 052366       | HOSE 3/8 ID X 61 in (1550 mm) LONG  |  | 1 |
| 030096       | HOSE, FLEXIBLE - CHARGE AIR<br>Location: turbo outlet & engine intake               |  | 2 |
| 531469       | HOSE, FLEXIBLE - CHARGE AIR<br>Location: CAC outlet                                 |  | 1 |
| 531471       | HOSE, FLEXIBLE - CHARGE AIR<br>Location: CAC inlet                                  |  | 1 |
| 052889       | HOSE, SILICONE 2 1/2" ID<br>Location : coolant pipes                                |  | 1 |

|                      |  |   |    |
|----------------------|--|---|----|
| 053617               | HOSE, SILICONE<br>Location : coolant pipes   |    | 3  |
| <b>CLAMPS+ SEALS</b> |  |   |    |
| 992081               | HOSE CLAMP CT CAILLAU 12-22<br>Location : coolant filter                                   |    | 4  |
| 992086               | HOSE CLAMP CT CAILLAU<br>Location : radiator outlet pipe                                   |    | 2  |
| 992089               | HOSE CLAMP CT CAILLAU 60mm-80mm<br>Location : coolant pipes                                |    | 16 |
| 1675066              | SEALING RING CHARGE AIR HOSE<br>Location: Engine intake elbow                              |   | 2  |
| 20592783             | CLAMP, CHARGE AIR HOSE D100 V-CLAMP DIA. 107.7<br>Location: Engine intake elbow            |  | 2  |
| 20592787             | CLAMP, TURBO DIFFUSER PIPE V-BAND DIA. 81.7<br>Location: Turbo to diffuser pipe connection |  | 1  |
| 21021850             | CLAMP, EXHAUST PIPE V-BAND 5 INCHES  |  | 2  |
| 21095726             | GASKET EXHAUST PIPE V-BAND JOINT, 5 INCHES   |  | 2  |
| 21096684             | GASKET, TURBO OUTLET<br>Location: Turbo to diffuser pipe connection                        |  | 1  |

|                          |   |   |      |
|--------------------------|---|---|------|
| 21490616                 | CLAMPS, SPRING LOAD - CHARGE AIR<br>Location: CAC outlet & inlet          |    | 8    |
| 21490630                 | CLAMP, SPRING LOAD - CHARGE AIR<br>Location: turbo outlet & engine intake |    | 4    |
| <b>SUPPORTS/BRACKETS</b> |   |   |      |
| 050265                   | COOLANT FILTER SUPPORT H3   |    | 1    |
| 050266                   | ALTERNATOR BATTERY CABLE SUPPORT  |    | 1    |
| 050303                   | ALTERNATOR TELLTALE BRACKET   |    | 1    |
| 050351                   | UPPER RADIATOR SUPPORT X3   |    | 1    |
| 053040                   | SUPPORT, COOLANT SURGE TANK   |   | 1    |
| 053043                   | SUPPORT, I/O MODULE   |  | 1    |
| 060102                   | ALTERNATOR BRACKET, LOWER   |  | 1    |
| 21185073                 | MOUNT, ANTI-VIBRATION   |  | 1    |
| <b>MISC.</b>             |   |   |      |
| 010060                   | DECAL, BELT ROUTING   |  | 1    |
| 069205                   | DECAL, WARNING  |  | 2    |
| 391028                   | INSERT, ALTERNATOR TELLTALE   |   | 1    |
| 506025                   | RUBBER EXTRUSION, BLACK   |  | 8 ft |
| 060297                   | STUD ADAPTER, ALTERNATOR M/F-M8   |  | 1    |

|                   |   |   |   |
|-------------------|---|---|---|
| 380360            | GROUND STUD                                   |    | 1 |
| 506040            | TAPE, ADHESIVE AD1 EPDM CC GY 5/16"X3/4"X25'  |   | 1 |
| 21937327          | FILTER, COOLANT                               |    | 1 |
| <b>ELECTRICAL</b> |   |   |   |
| 012921            | GROUND STUD                                   |    | 1 |
| 561608            | TERMINAL                                      |    | 4 |
| 561610            | CONNECTOR HOUSING, PED WEATHER PACK 4 WIRES   |   | 1 |
| 561783            | CAVITY PLUG, CONNECTOR                        |  | 4 |
| 562113            | TELLTALE LIGHT MODULE                         |   | 1 |
| 563593            | CONNECTOR, WITH END-OF-LINE 120 OHMS RESISTOR |  | 2 |
| 563750            | FUSE HOLDER, AMG TYPE                         |  | 1 |
| 564520            | FUSE, AMG 300A                                |  | 1 |
| 564612            | CIRCUIT BREAKER BOX                           |  | 1 |
| 565191            | FAN, ELECTRIC                                 |  | 8 |

|               |   |   |    |
|---------------|---|---|----|
| 563533        | HAND GUARD, FAN                         |    | 8  |
| 22722850      | I/O-B MULTIPLEX MODULE                  |    | 1  |
| 23499009-EFD  | MCM, PROGRAMED                          |    | 1  |
| HARNESSES     |   |   |    |
| 060682        | ALTERNATOR POWER CABLE                  |    | 1  |
| 068820        | HARNESS KIT, FAN DRIVE                  |    | 1  |
| 069245        | FAN DRIVE POWER CABLE, 2700 mm          |   | 1  |
| 069246        | GROUND CABLE, FAN DRIVE                 |    | 1  |
| 069504        | GROUND CABLE, LEFT ALTERNATOR           |   | 1  |
| 069511        | CONTROL HARNESS LEFT ALTERNATOR         |  | 1  |
| 23445869      | MCM TO I/O-B INTERFACE HARNESS          |   | 1  |
| 23488790      | FAN TO RJB INTERFACE HARNESS            |   | 1  |
| 23490553      | VEHICLE INTERFACE HARNESS               |   | 1  |
| 23498450      | MASTER RELAY TO 300A FUSE CABLE, 300 mm |   | 1  |
| HARDWARE MISC |   |   |    |
| N37749        | TIE, NYLON DOUBLE                       |  | 12 |
| 504016        | TIE, NYLON BLACK (LARGE)                |  | 58 |
| 509491        | TIE, NYLON LARGE EXTRA STRONG 250 LBS   |  | 30 |
| 504013        | MOUNT, TIE HOLE 1/4"                    |  | 15 |

|         |  |   |    |
|---------|--|---|----|
| 504751  | MOUNT, TIE SWIVEL                                |    | 4  |
| 504750  | CABLE TIE W/FIR TREE MOUNT(120 POUNDS)           |    | 2  |
| 509490  | MOUNT, TIE DOUBLE GRAY                           |    | 17 |
| 562679  | MOUNT, SQUARE SELF-ADHESIVE BLACK                |    | 4  |
| 5001965 | SPRING NUT                                       |    | 18 |
| RIVETS  |  |   |    |
| 504117  | RIVET, 3/16                                      |    | 5  |
| 504379  | RIVET, POP DOME SS OE 3/16X1/4                   |   | 20 |
| 504610  | RIVET MGL PRDG SS 1/4X5/8                        |  | 18 |
| WASHER  |  |   |    |
| 500321  | WASHER, FLAT SPR N500 .331X.827X.098(M8,5/16)    |   | 1  |
| 500449  | WASHER, FLAT SS .687X1.5X0.078 (M16,5/8)         |   | 1  |
| 500482  | WASHER, SPLIT LOCK Z050 .506X.873X.125 (M12,1/2) |   | 1  |
| 500942  | WASHER, SPLIT LOCK N500 8.1X14.8X2 (M8,5/16,#18) |   | 4  |
| 502570  | WASHER, SPLIT LOCK SS 6.1X11.8X1.6 (M6,#12)      |   | 85 |
| 502573  | WASHER FL SS 6.4 X 12.0 X 1.6 (M6,1/4)           |   | 1  |
| 502709  | WASHER   |   | 9  |
| 507657  | WASHER, BANJO FITTING M14                        |   | 8  |
| 5001341 | WASHER, FLAT SS 8.4X17X1.6 (M8,5/16)             |   | 6  |
| 5001737 | WASHER, SPLIT LOCK N500 10.2X18.1X2.2 (M10,3/8)  |   | 4  |

|          |   |  |    |
|----------|---|--|----|
| 5001751  | WASHER, FLAT N500 10.5X26X2 (M10,3/8)                   |  | 10 |
| 5001833  | WASHER, BELLEVILLE SPR SS 301<br>6.65X17.4X1.27(M6,1/4) |  | 32 |
| 5001868  | WASHER, BELLEVILLE SS 8.4X18X2 (M8,5/16)                |  | 4  |
| 5001935  | WASHER, FLAT SS 10.5X18X1.6 (M10,3/8)                   |  | 1  |
| 5002008  | WASHER, FLAT HARD N500 13X35X5 (M12,1/2)                |  | 1  |
|          | NUTS  |  |    |
| 500998   | NUT HEX BR 1/2-13                                       |  | 1  |
| 502837   | NUT HEXF STO N500 M8-1.25                               |  | 2  |
| 502854   | NUT HEX N500 M6-1                                       |  | 3  |
| 502859   | NUT HEX NYRT NX500 M10-1.5 G10                          |  | 4  |
| 5001180  | NUT 10-24   |  | 4  |
| 5001182  | NUT HEX NYRT SS M6-1                                    |  | 1  |
| 5001665  | NUT HEX NYRT NX500 M22-2.5                              |  | 1  |
| 5001728  | NUT HEXF STO N500 M12 CL10                              |  | 1  |
| 5001761  | NUT HEXF NYRT NX500 M12-1.75 G8                         |  | 4  |
| 5001930  | NUT HEXF NYRT NX500 M10-1.50 PC 10                      |  | 2  |
| 5001932  | NUT HEXF NYRT NX500 M6-1 G8.8                           |  | 3  |
| 5001983  | NUT HEX NYRT NSS M8-1.25X9.5                            |  | 5  |
| 21429955 | NUT, FLANGED  |  | 1  |
|          | SCREWS  |  |    |
| 500119   | SCREW, CAP HEX SS NSS M8X1.25X20                        |  | 4  |
| 500594   | SCREW 7/16-20X1.25 G8                                   |  | 1  |
| 500623   | SCREW TC  |  | 2  |
| 500658   | SCREW TC PAN PH Z050 10-24X3/4                          |  | 11 |
| 502719   | SCREW, CAP HEX SS NSS M10X20 G8.8                       |  | 1  |
| 502686   | SCREW, CAP HEX SS NSS M6X30                             |  | 33 |
| 502804   | SCREW, CAP HEX N500 M10-1.5X25 G8.8                     |  | 8  |
| 502888   | SCREW, HEX Z050 M6-14X35 G8.8                           |  | 3  |
| 502848   | SCREW TC HEX F N500 1/4-20X3/                           |  | 22 |

|          |   |  |    |
|----------|---|--|----|
| 502950   | SCREW SHR HEXF N500 12.9X160LG CL10.9       |  | 1  |
| 5001296  | SCREW, CAP HEXFN500 M12-1.75 X 80 CL10.9 PT |  | 6  |
| 5001447  | BOLT 10-24X5/8                              |  | 4  |
| 5001643  | SCREW, CAP HEXF G500 M8-1.25X25 G8.8 PT     |  | 3  |
| 5001697  | SCREW, CAP HEX SS NSS M6X16                 |  | 85 |
| 5001738  | SCREW, CAP HEX N500 M8X30 G8.8 FT           |  | 4  |
| 5001745  | SCREW, CAP HEX N500 M8-1.25X25 G8.8         |  | 2  |
| 5001786  | SCREW, CAP HEXF AD N500 M12-1.75X30 G8.8    |  | 1  |
| 5001799  | SCREW, CAP HEXF N500 M10-1.5 X 70 G10.9     |  | 4  |
| 5001800  | SCREW, CAP HEXF N500 M10X45 G10.9           |  | 1  |
| 5001940  | SCREW CAP HEX N500 M12X1.75X140             |  | 4  |
|          | INSTRUCTIONS                                |  |    |
| IS-19901 | INSTRUCTION SHEET                           |  | 1  |
| FI-19901 | FEUILLE D'INSTRUCTION                       |  | 1  |

Other parts or products that may be required:

| Part No. | DESCRIPTION                           |
|----------|---------------------------------------|
| 680459   | Loctite 404, INSTANT ADHESIVE 9.3 gr  |
| 680098   | LOCTITE 567 THREAD SEALANT 250 ML     |
| 680038   | LOCTITE 243, BLUE THREAD LOCKER 50 ML |
| 684013   | LOCTITE COLOR GUARD RUBBER COATING    |

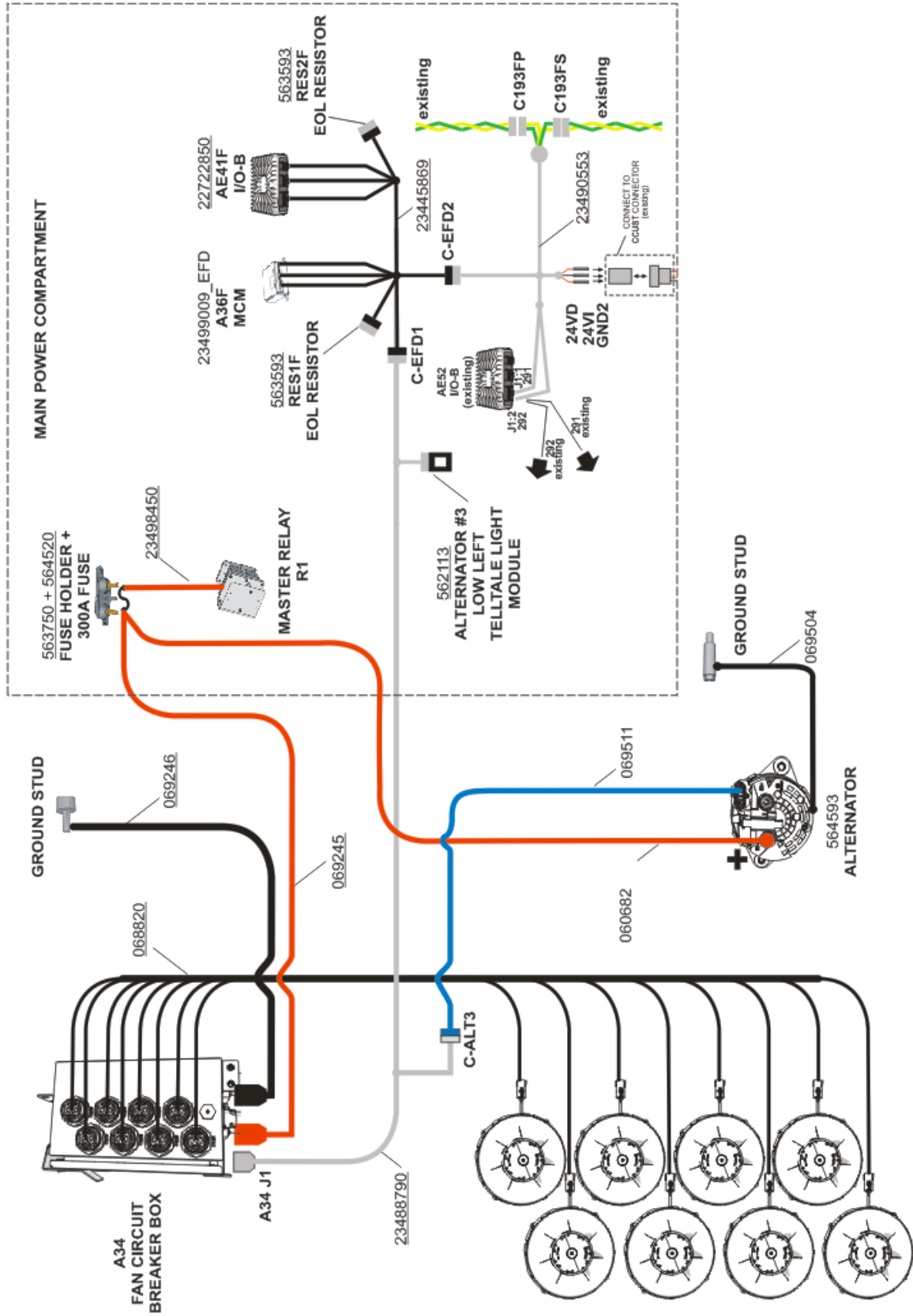
**PROCEDURE**



**DANGER**

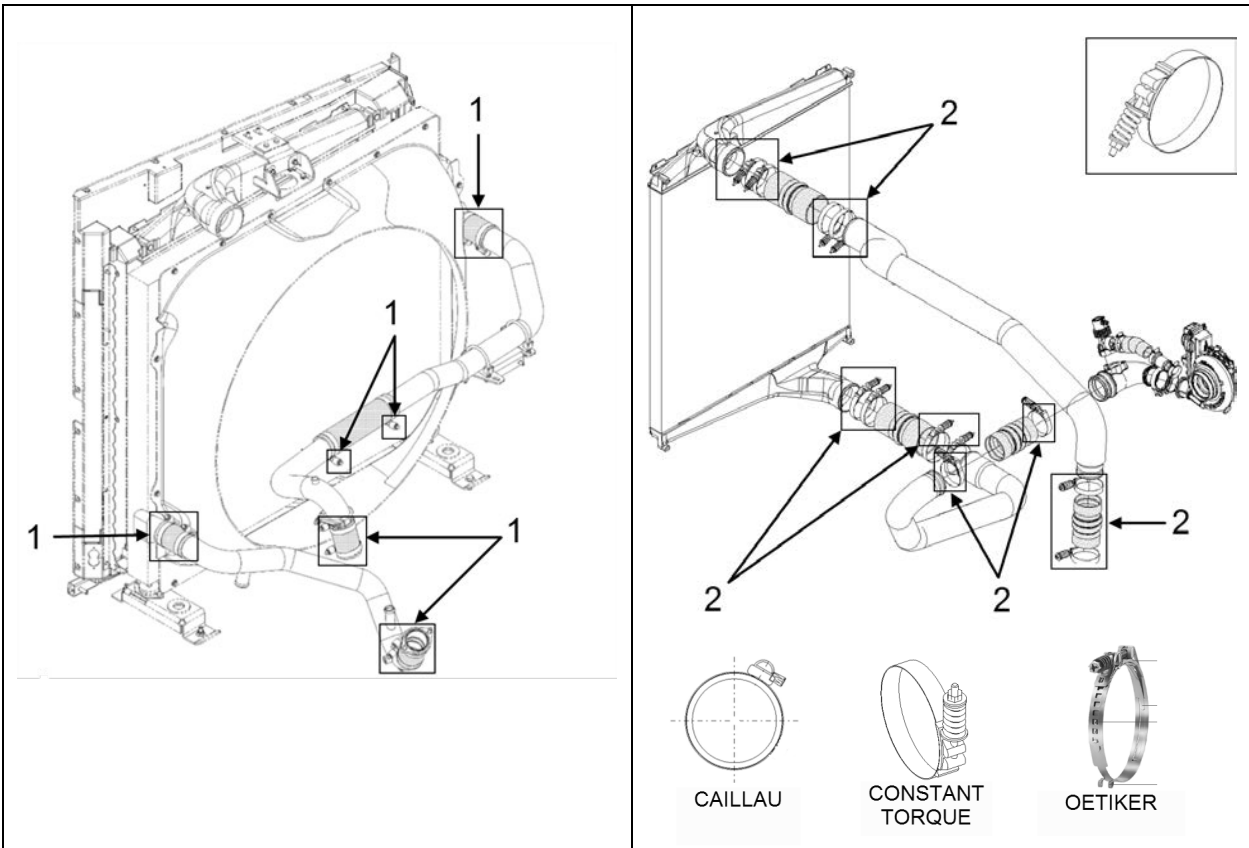
Park vehicle safely, apply parking brake, stop the engine. Prior to working on the vehicle, set the ignition switch to the OFF position and trip the main circuit breakers equipped with a trip button.

## DIAGRAM OF ELECTRICAL CONNECTIONS



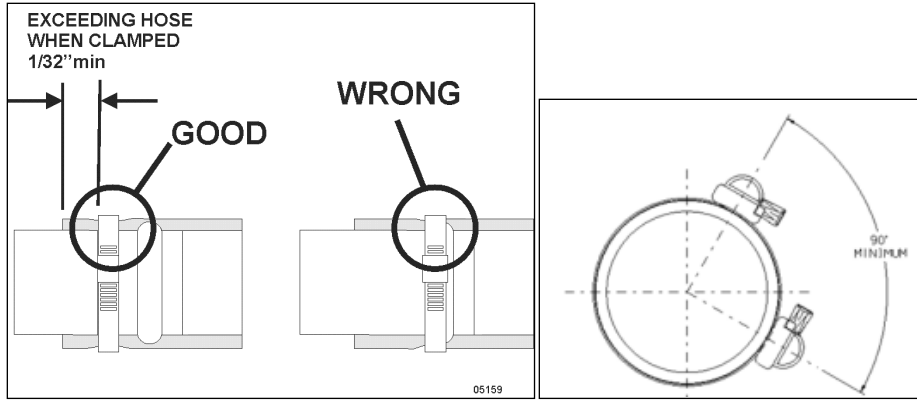
# PREVOST

## HOSE CLAMP TORQUE (coolant lines and charge air cooler)



### HOSE CLAMPS

| No                    | DESCRIPTION  | TORQUE         |
|-----------------------|--|----------------|
| 1<br>(Ø 2 ½" or less) | Constant-Torque hose clamps - coolant lines                  | 90-100 lbf-in  |
|                       | Oetiker hose clamps – Green spring - coolant lines           | 12-18 lbf-in   |
|                       | Oetiker hose clamps – unpainted spring - coolant lines       | 8-9 lbf-in     |
|                       | Caillau hose clamps - coolant lines                          | 30 lbf-in      |
| 2<br>(Ø 4 ¼")         | Constant-Torque hose clamp 4.25 in - charge air cooler (CAC) | 4.5-5.5 lbf-ft |



# PREVOST

1. Raise the L.H. side rear-hinged fender.

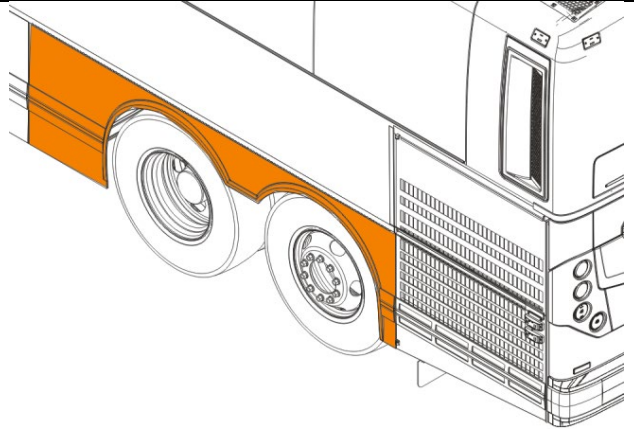


FIGURE 1

## Drain the cooling system

2. Connect the coolant extractor. Use the coolant extractor to drain the coolant from the engine. An alternate method is to drain the coolant into a suitable container using the drain hose.

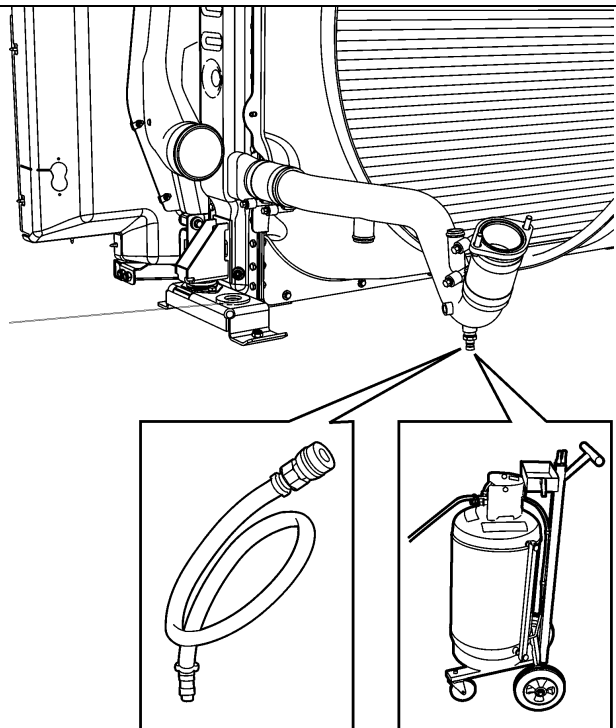


FIGURE 2

3. Unfasten two (2) cap screws and remove **access panel** located behind the tag axle L.H. side wheel.

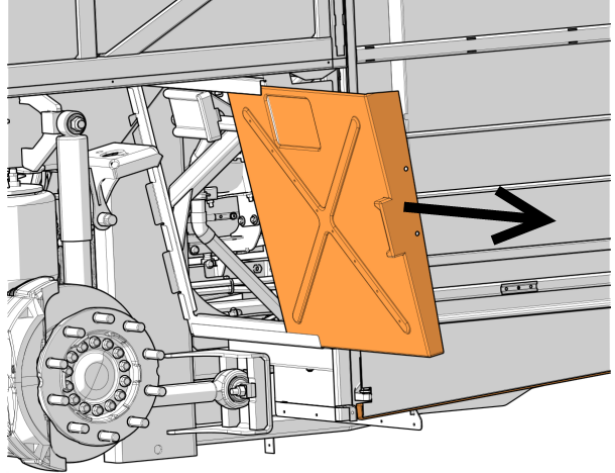


FIGURE 3

4. Open radiator door to access radiator assembly. Unfasten **upper arm assembly**.

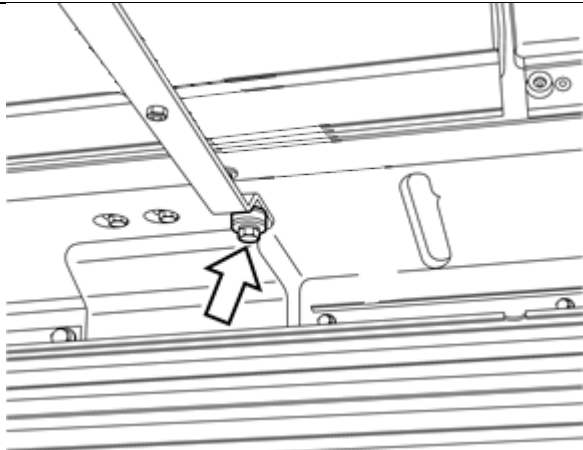


FIGURE 4

5. Remove radiator **sealing frame**.

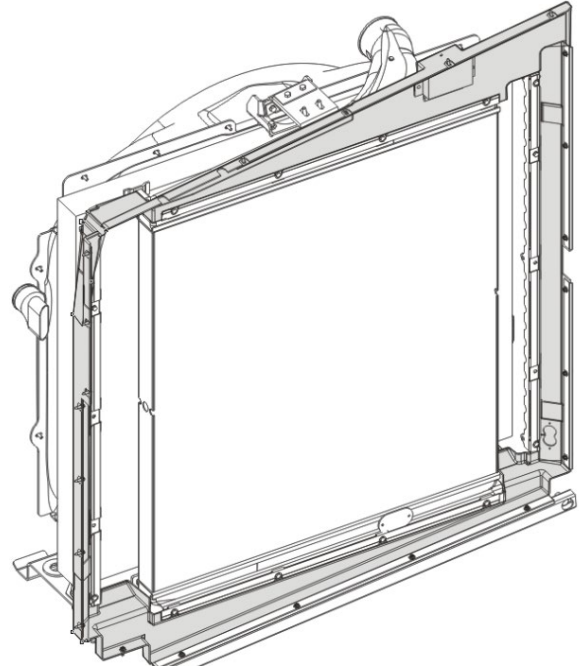


FIGURE 5

6. Remove the **rear bumper** (undo three nuts each side).

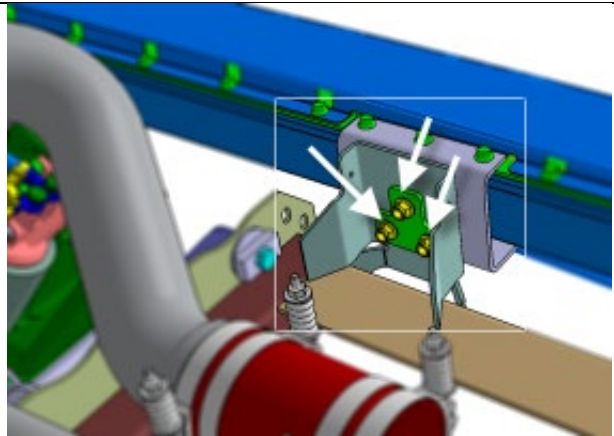


FIGURE 6

7. Remove the fan drive casting.

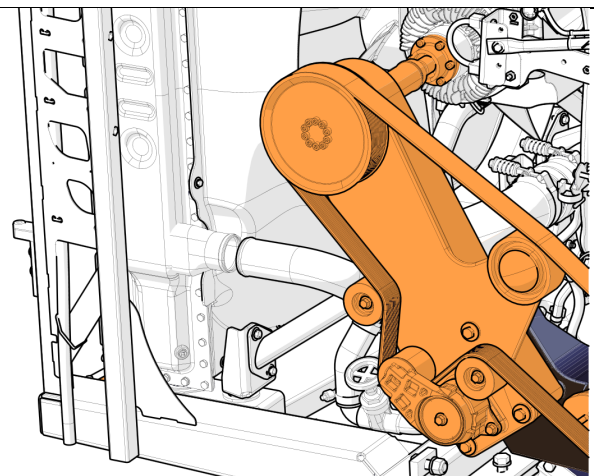


FIGURE 7

8. **Remove clamps** and then break hoses of the coolant and charge air pipes shown.

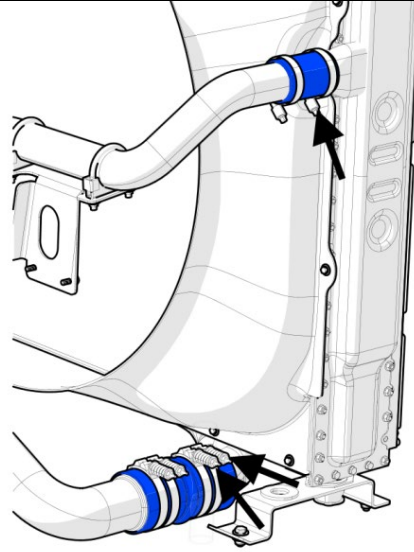


FIGURE 8

9. **Remove** the coolant and charge air hose **clamps** shown then break hoses loose.

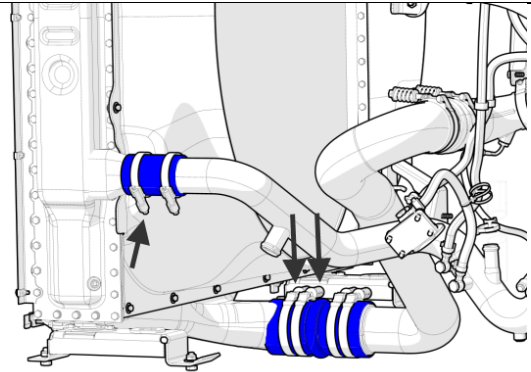


FIGURE 9

10. Remove the upper radiator assembly **support bracket**.

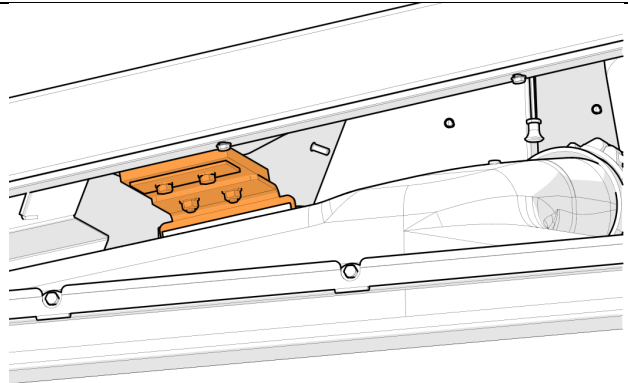


FIGURE 10

11. Remove the radiator assembly protector tube.

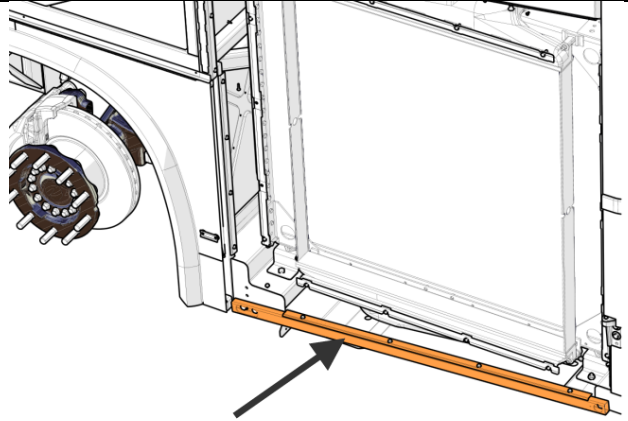
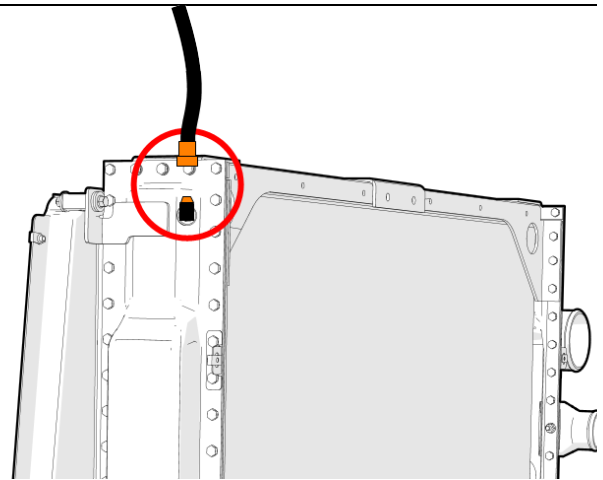


FIGURE 11

12. Disconnect the **radiator vent hose** on top of the radiator.



13. Disconnect **electrical connector** from the fan clutch. The remaining connector on the chassis cable will be capped and left in place.

14. Remove fan **drive shaft** fasteners at the fan clutch.

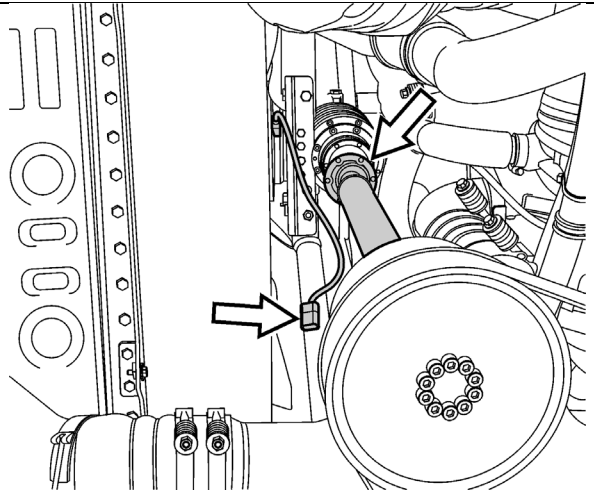


FIGURE 12

15. Open the secondary lock of **connector #561610**. Insert a **cavity plug #561783** in each of the four (4) cavities with the smallest end protruding as shown on the example at right. Close the secondary lock.
16. Cap the chassis fan clutch cable with this connector. Secure the connector on the existing harness:



FIGURE 13

- **nylon tie #504016 (1x)**



FIGURE 14

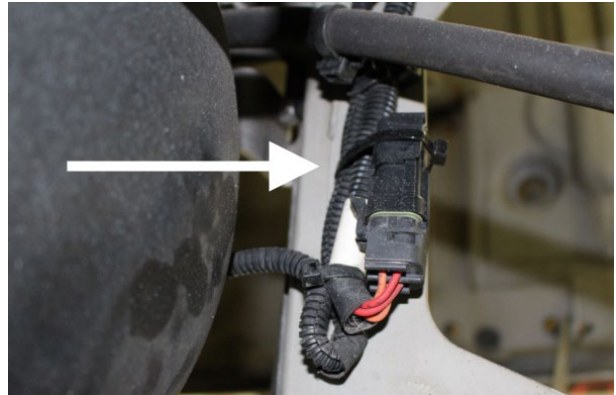


FIGURE 15

17. Unscrew all lower radiator assembly **mounting fasteners** (2 bolts on R.H. side, 2 bolts on L.H. side).

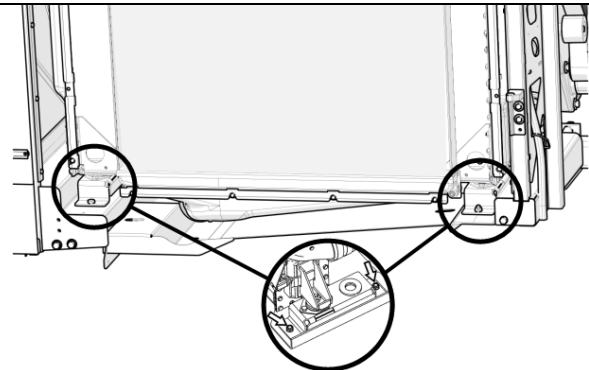


FIGURE 16

18. Position a **forklift** under the radiator assembly that is capable of safely lifting the radiator. With assistance, slide radiator assembly out and onto the forklift. Transfer radiator assembly to a secure location.

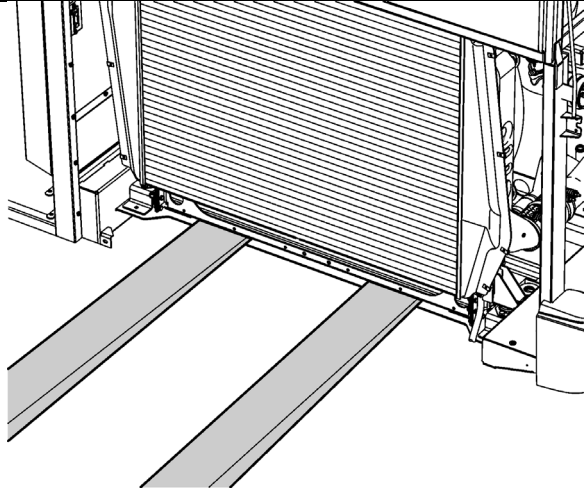


FIGURE 17

19. **Remove** the **tripod** from the radiator/CAC assembly.

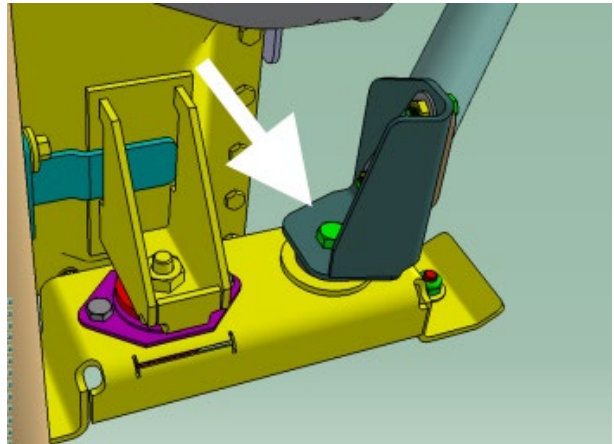


FIGURE 18

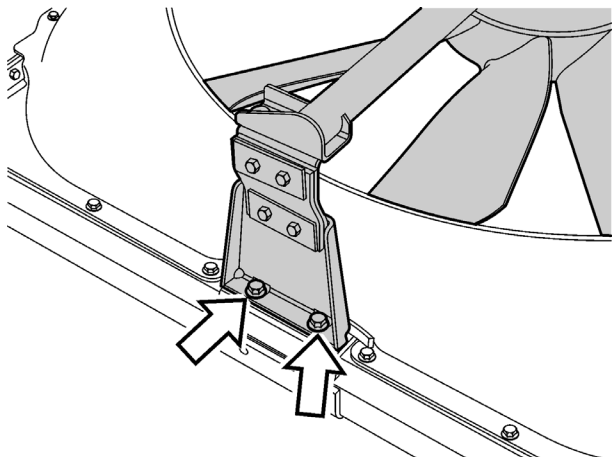


FIGURE 19

20. **Remove the fan shroud.**

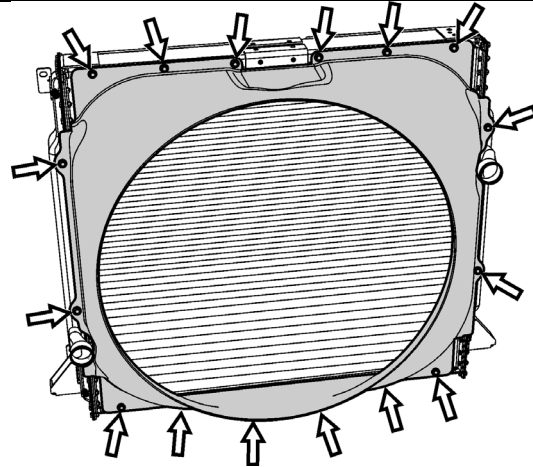


FIGURE 20

21. The new cooling pack arrangement requires being located **four inches** closer to the engine to give the needed clearance for the electric fans. For this reason, **rotate** both the radiator/CAC assembly **mounting support 180°** and reinstall.

**BEFORE**

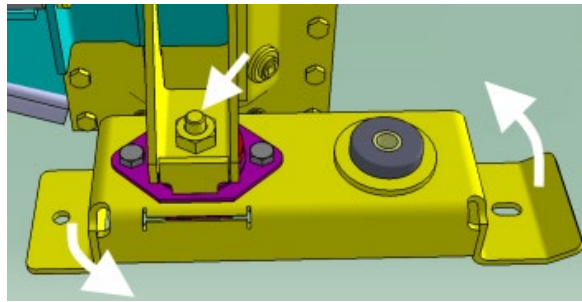


FIGURE 21: MOUNTING SUPPORT IN INITIAL POSITION

**AFTER**

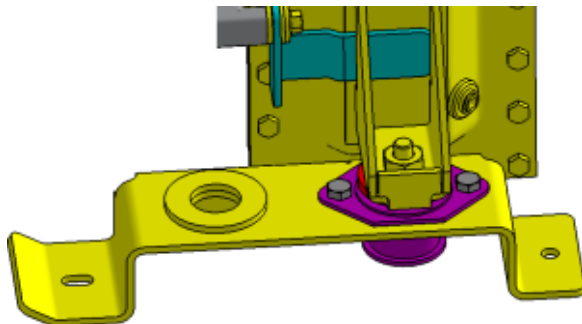


FIGURE 22: MOUNTING SUPPORT AFTER 180° ROTATION

22. Remove the exhaust pipe section located between the DPF and the flexible section.

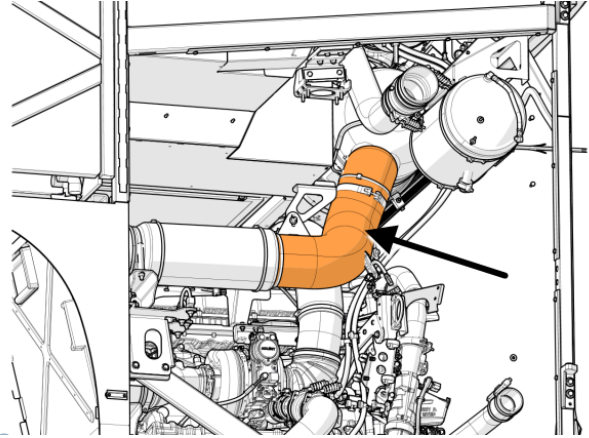


FIGURE 23: REMOVE THIS EXHAUST PIPE SECTION

23. On the engine hot side, remove the following pipes:

- radiator outlet pipe
- CAC inlet pipe

**Keep the fittings found on the radiator outlet pipe for reuse**

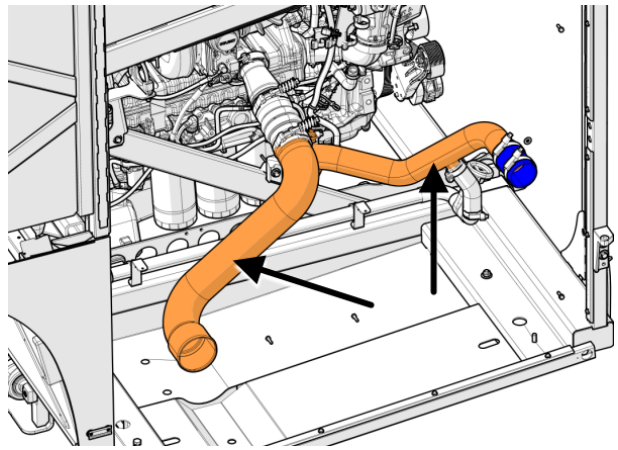


FIGURE 24

24. Undo the two (2) V-band clamps and then remove the engine intake elbow.

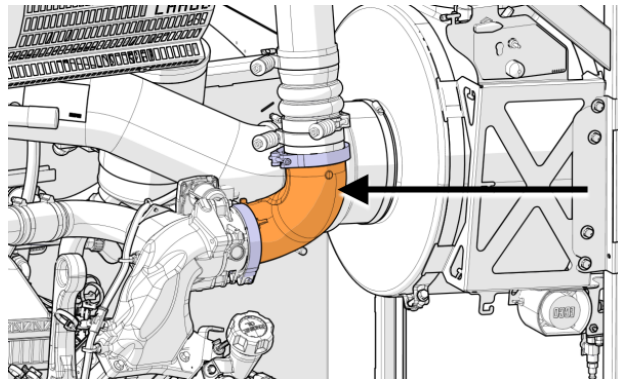


FIGURE 25: REMOVE THE INTAKE ELBOW

25. Remove the pipe (item A) section located downstream of the engine air filter. Prior to do so, disconnect the air compressor fresh-air inlet pipe (item B) connected to pipe A.

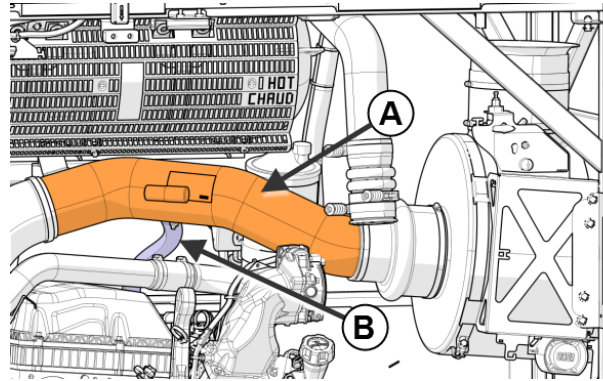


FIGURE 26

26. On the engine hot side, remove the radiator inlet pipe.

**KEEP THE BLUE HOSE, IT WILL BE USED AS PROTECTIVE SHEATH**

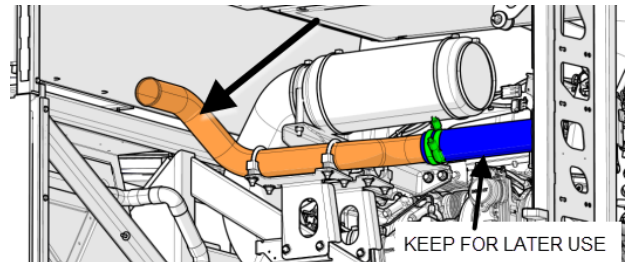


FIGURE 27

27. Remove and discard the CAC outlet pipe. It is possible to remove this pipe by taking it out from the left side (hot side)

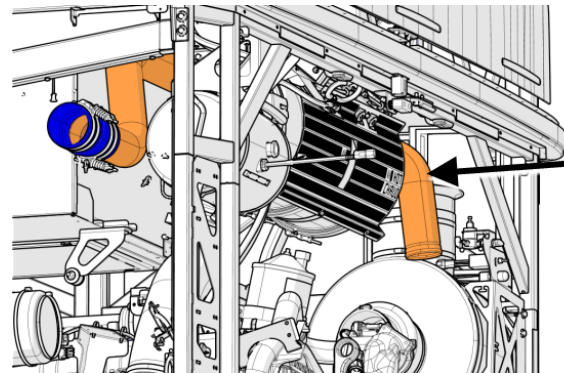


FIGURE 28



FIGURE 29

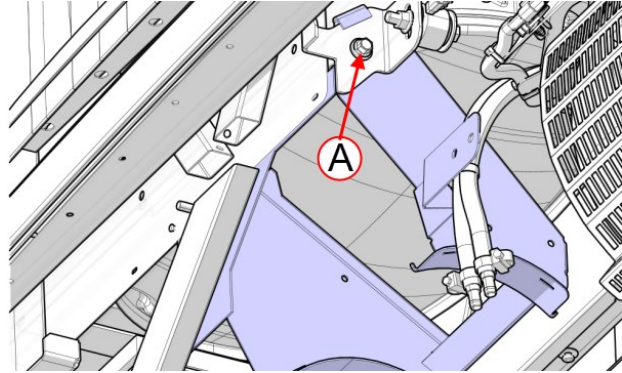


**FIGURE 30**

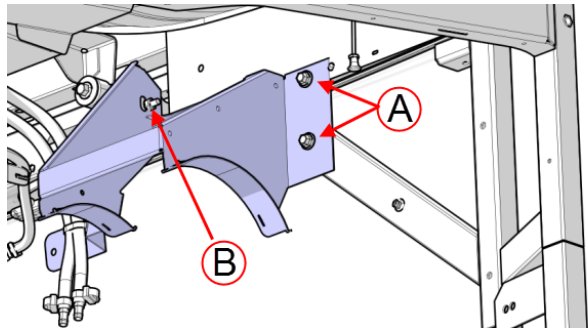


**FIGURE 31**

28. Replace the existing coolant surge tank support with the coolant tank support #053040 included in the kit. Use the existing hardware. Add one (1) new washer #500321 and one (1) new nut #5001983.

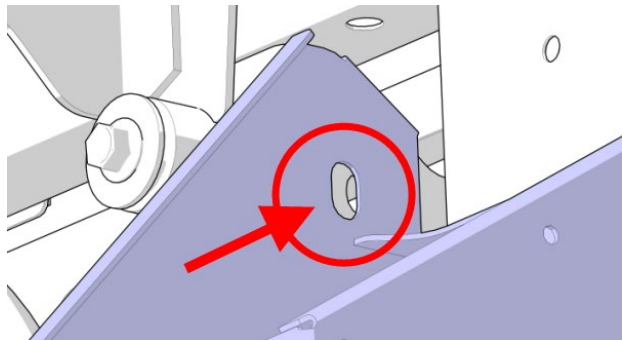


**FIGURE 32**  
**A: REUSE EXISTING HARDWARE**



**FIGURE 33**  
**A: REUSE EXISTING HARDWARE**  
**B: NEW WASHER #500321, NEW NUT #5001983.**

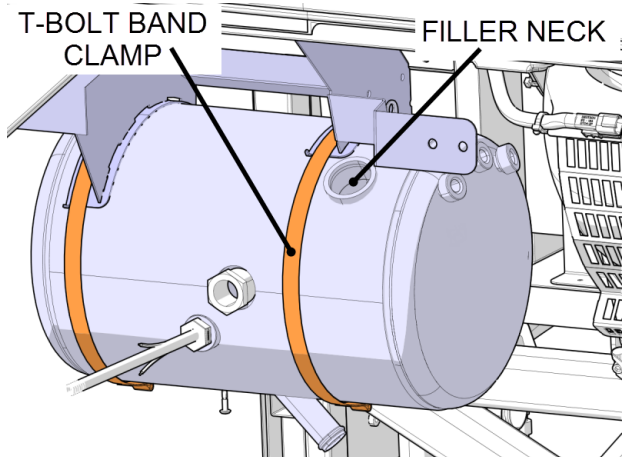
29. Depending on the vehicle model year, drilling of the mounting hole shown might be necessary (see image at right).



**FIGURE 34**

30. Reinstall the surge tank, slightly moved to the right in comparison with the former installation.

Note the T-bolt band clamp now located on the other side of the filler neck on the image at right.



**FIGURE 35**

31. The area identified on the images at right will be in interference with the radiator. For this reason, some modifications are necessary to eliminate the interference.

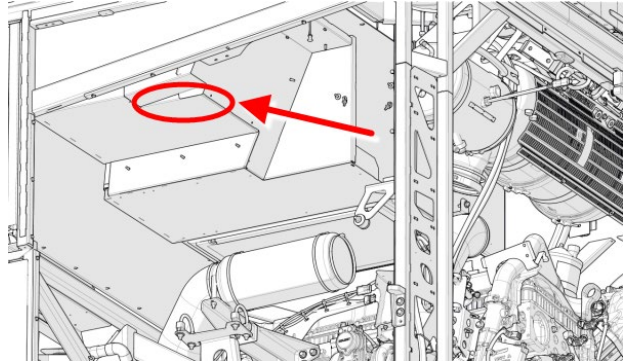


FIGURE 36

32. Cut the sheet metal along the red lines as shown on the image at right.

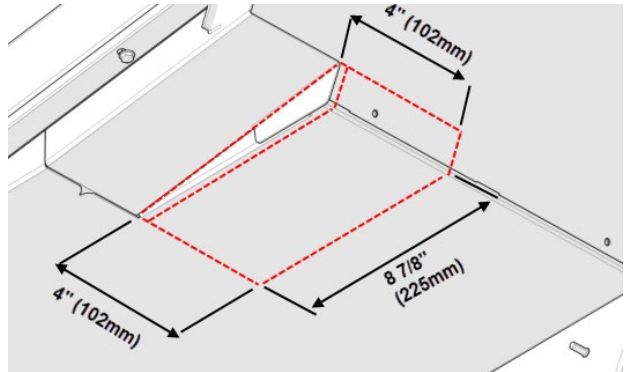
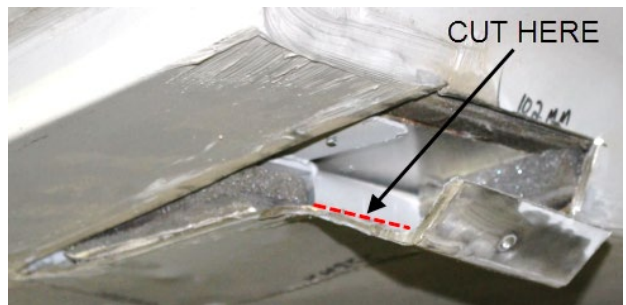


FIGURE 37



FIGURE 38

33. Cut along the red line shown on the picture to separate the sheet metal from the steel fold.



34. The bolt seen on the picture at right secures the last R.H.seat. This bolt is too long and must be changed for a shorter one.



FIGURE 39

35. Unscrew the bolt identified on the picture and change it for screw #500594.



FIGURE 40

36. Cut the steel fold shown on the picture at right.

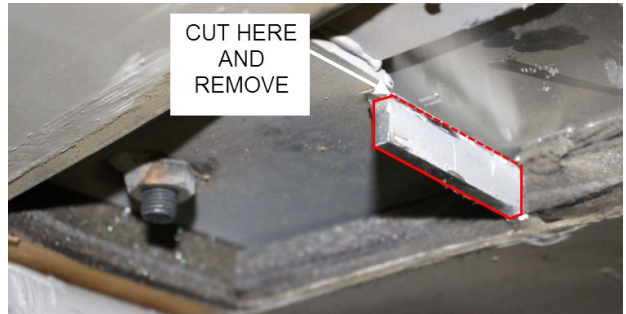


FIGURE 41

37. Fold over the sheet metal as shown on the picture and secure to the structure using the following hardware:

- **rivet #504117 (5x)**

38. Finally, apply sealant to assure water tightness.



FIGURE 42

39. Remove all the drive belts mounted on the crank pulley.

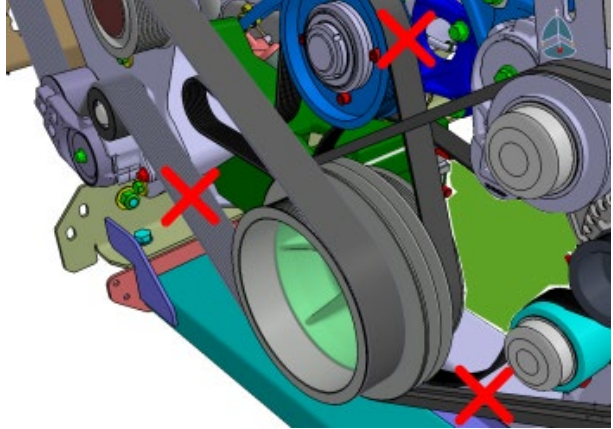


FIGURE 43

40. Remove the crank pulley. Discard the 6 bolts.

**NOTE:** *On vehicles prior to serial G-5986 (2016) equipped with a trailer hitch, keep the existing crank pulley (14 ribs) in place.*

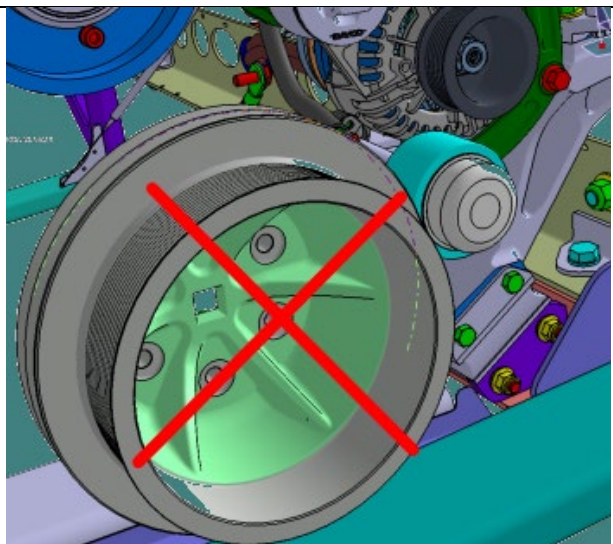


FIGURE 44

- 
41. Remove the rust, clean and prepare the surface on the vibration damper as shown. Work the surface to achieve a smooth finish.



**FIGURE 45**



**FIGURE 46**

- 
42. Properly support the engine as one of the engine support will be interchanged in the upcoming steps.



**FIGURE 47**

43. Remove the two (2) coolant hoses shown on the image. Keep the two (2) banjo fittings for later use.



BANJO FITTING

LEAVE THE FEMALE  
PUSH-LOK FITTING  
IN PLACE

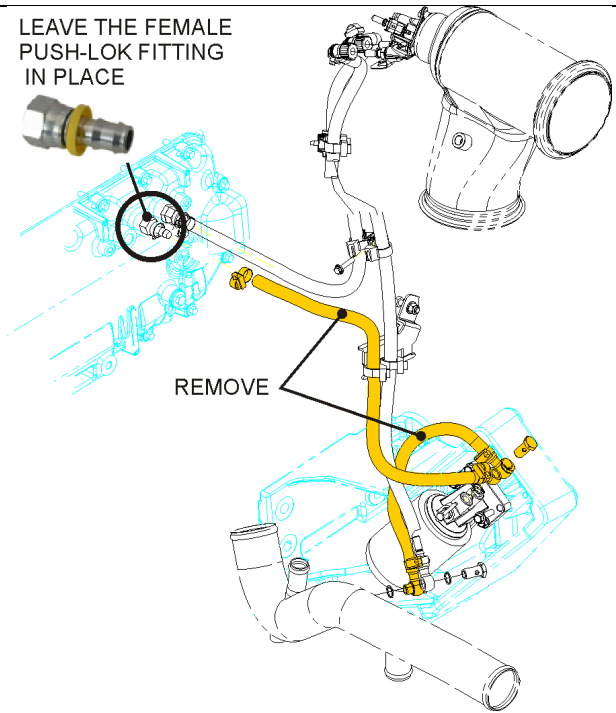


FIGURE 48

44. Remove the L.H. rear engine support (10 bolts). Keep the hardware for reinstallation.

***Take note that the water pump belt idler/tensioner assembly will be reused as is. Do not take apart tensioner or idler.***

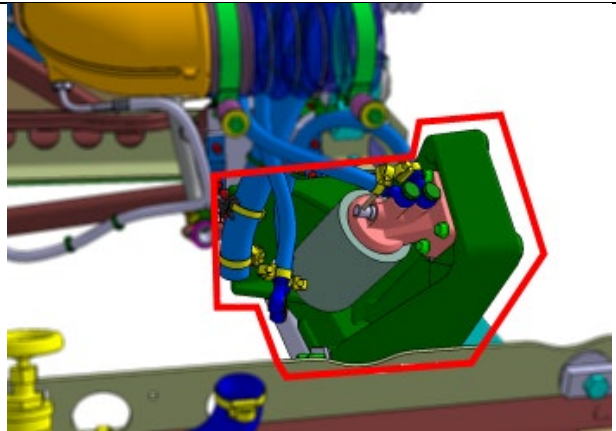


FIGURE 49: L.H. REAR ENGINE SUPPORT

45. Remove the water pump idler/tensioner assembly from the former engine mount. To do so, unscrew three (3) bolts from the back of the engine mount.

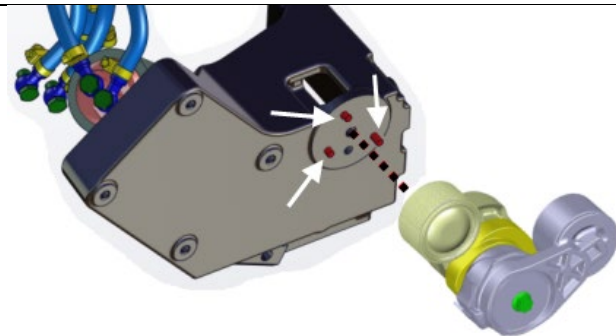


FIGURE 50

46. Reinstall idler/tensioner assembly as a unit on the new L.H. engine mount #012942.

**Mount the idler/tensioner assembly using three (3) cap screws #5001643**

**Tighten to 14-17 lb-ft**

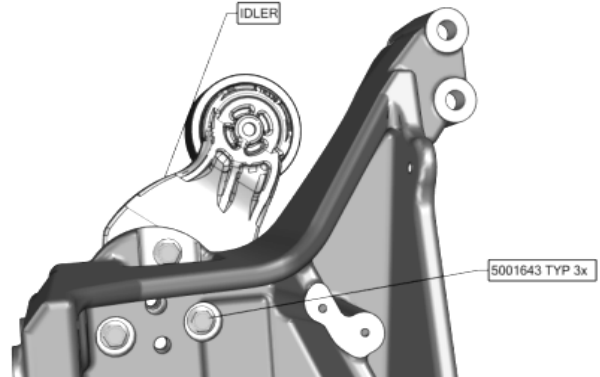


FIGURE 51

47. Install the new engine mount #012942 using seven (7) M14 screws saved from the former engine support with this exception of:

- **Ground stud #012921 (1x) and nylon insert NYRT nut #5001665 (1X)**
- **Isolator cap screw #5001940 (2X)**
- **Nut #5001761 (2X)**

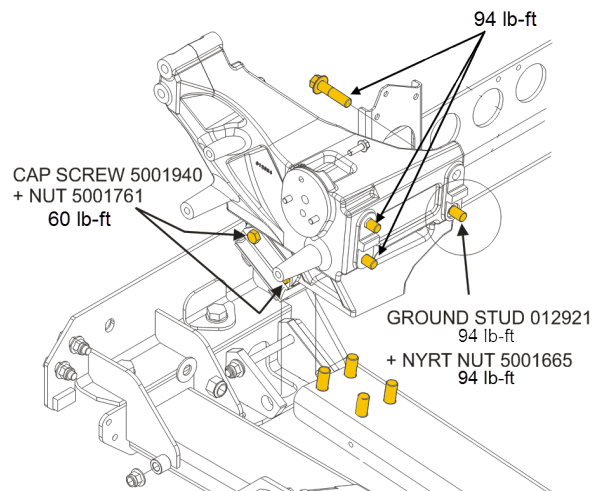


FIGURE 52

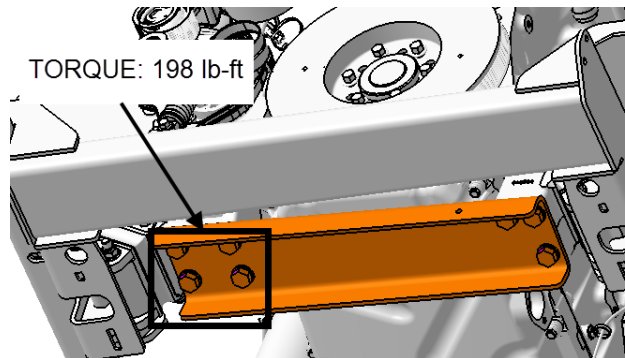


FIGURE 53: FOUR (4) SCREWS UNDER THE REINFORCEMENT CHANNEL

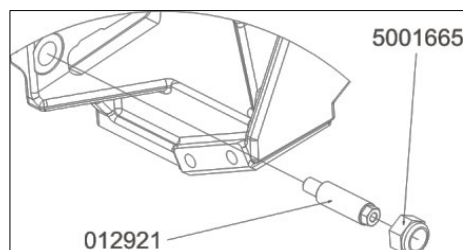


FIGURE 54: REAR VIEW – GROUND STUD

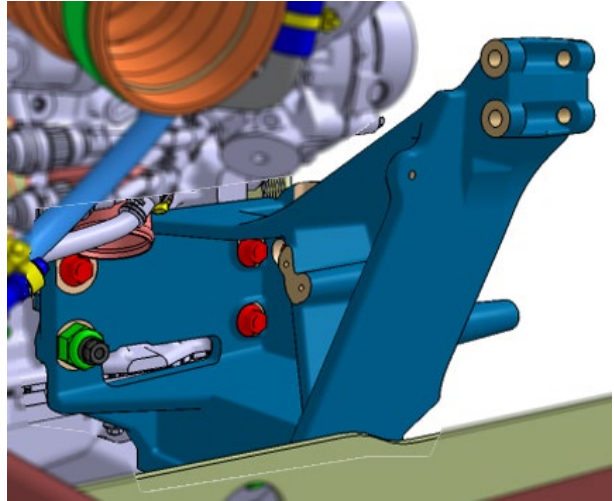


FIGURE 55

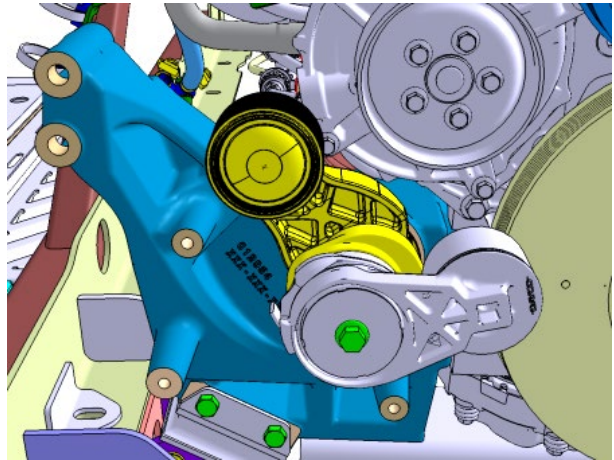


FIGURE 56

48. Install the new crank pulley using six new bolts #5001296. Use blue Loctite on the bolt threads.

**Torque to 26 lb-ft in this numerical order: 1, 2, 3, 4, 5, 6, 1**

**Once done perform a final tightening to the value of 66 lbf-ft.**

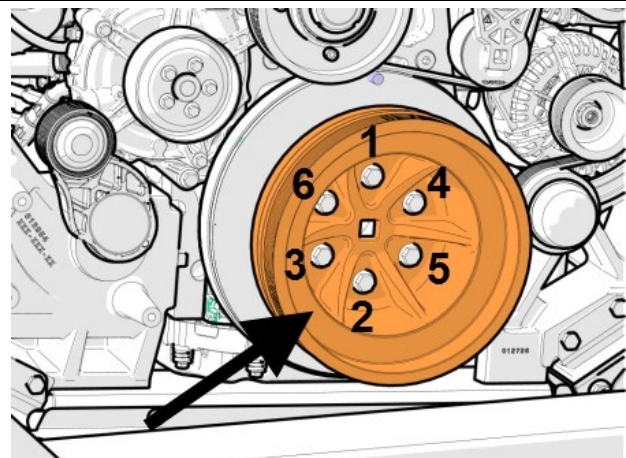


FIGURE 57

49. Reinstall the water pump drive belt.

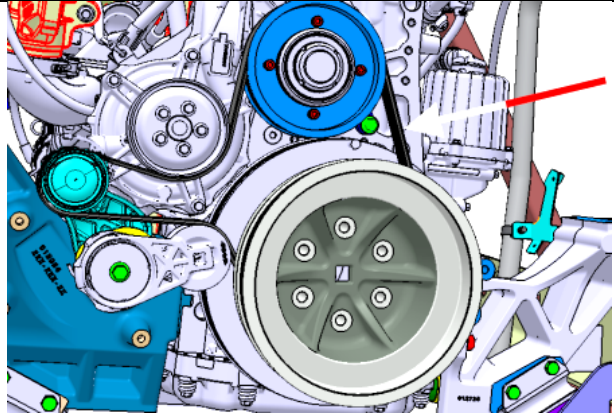


FIGURE 58: WATER PUMP DRIVE BELT

50. Reinstall the A/C compressor drive belts.

51. Install the idler support #011213 using three (3) screws #5001799. At the same time, install the alternator lower bracket #060102.

**screws #5001799 prescribed torque: 48 lbf-ft**

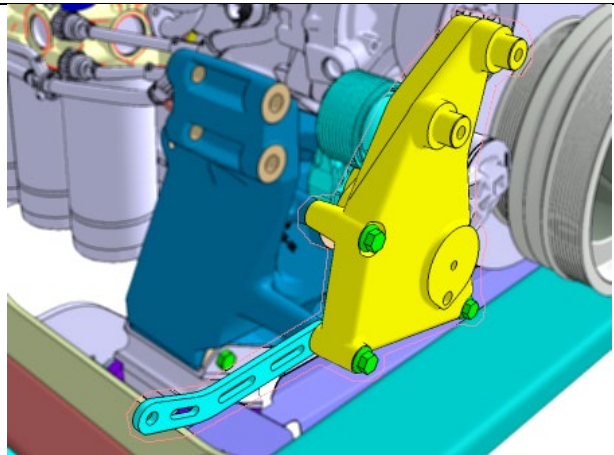


FIGURE 59: BRACKET #060102

52. Make a smooth round clearance in the engine cradle to allow required space for the alternator lower bracket #060102 installed at the previous step. Carefully work the edge to achieve a smooth finish and contour.

Measurements:  $\leftrightarrow 2''$ ,  $\updownarrow \frac{3}{4}''$

**Apply paint to protect the metal against corrosion**

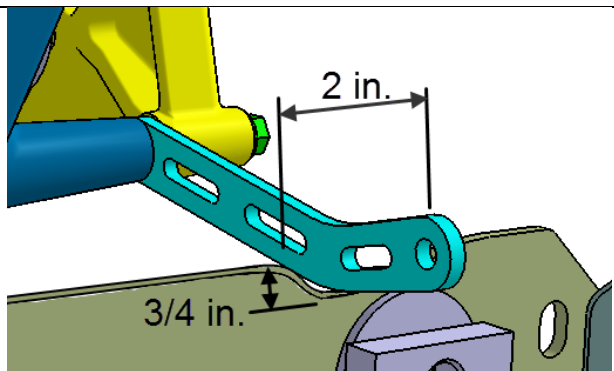
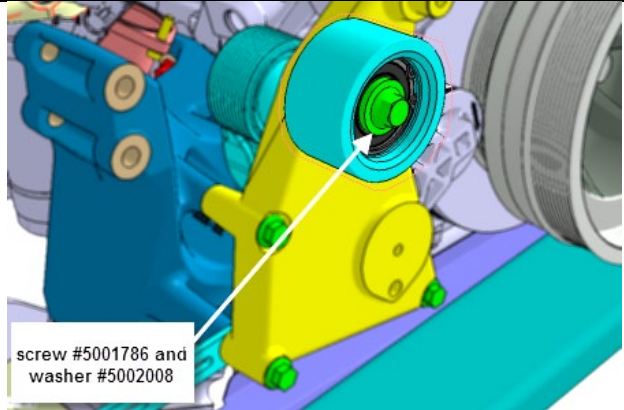


FIGURE 60

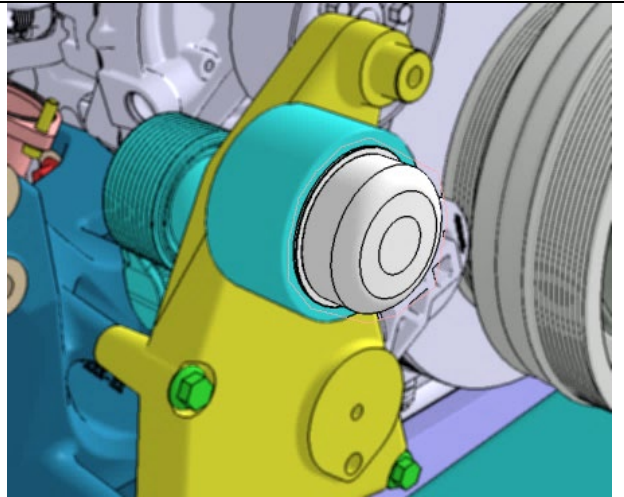
53. Install the new idler #012349 with one (1) screw #5001786 and one (1) washer #5002008.

***Tighten to 59 lb-ft***



**FIGURE 61**

54. Install the dust cap #453076.

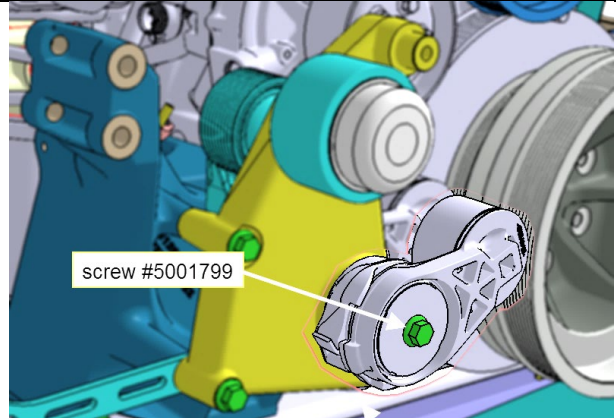


**FIGURE 62**



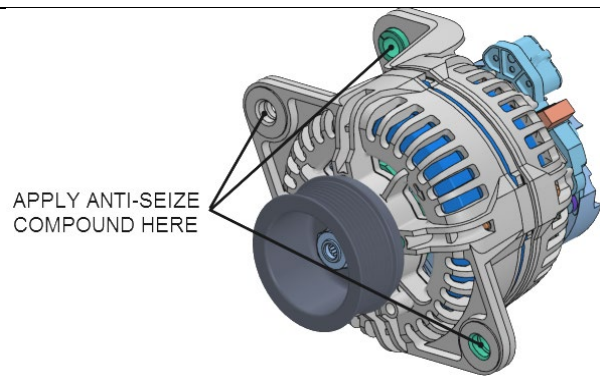
**FIGURE 63**

55. Install the new alternator belt tensioner #510991. Secure with one (1) screw #5001799 on which **blue Loctite** is applied on the threads.

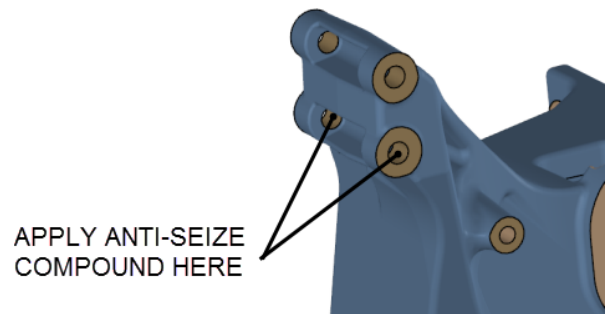


**FIGURE 64: TENSIONER MOUNTING SCREW TORQUE : 48 lb-ft**

56. Apply anti-seize compound (Prevost p/n: 680335) inside the alternator mounting ears and inside the sleeves found on the support attached to the engine.



**FIGURE 65**



**FIGURE 66**

57. Install the alternator.

**A:** screw #502950 & nut #5001728 (torque: 82 lbf-ft)

**B:** screw #5001800 & nut #5001930 (torque: 48 lbf-ft)

**C:** apply blue Loctite and then torque to 48 lbf-ft

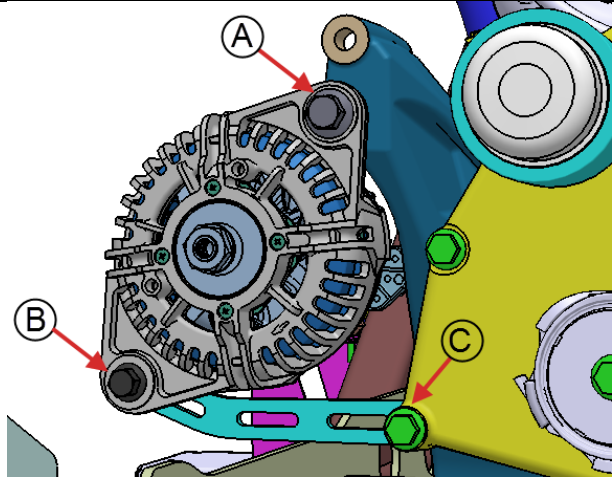


FIGURE 67

**Simultaneously, install the alternator “power cable” support #050266 to the alternator as shown on the picture.**



FIGURE 68

58. Install the alternator pulley #0600265 (for further details, refer to Maintenance Information IM16-17).

**Use washer #500449 and flanged nut #21429955**

**torque: 75 lbf-ft**

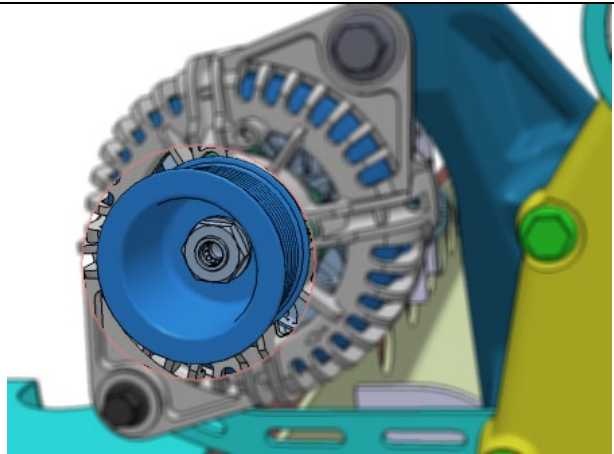


FIGURE 69

59. Install the alternator drive **belt #506026**.

**NOTE:** Use **belt #506080** instead if the **original crank pulley is still in place (vehicle equipped with a trailer hitch)**.

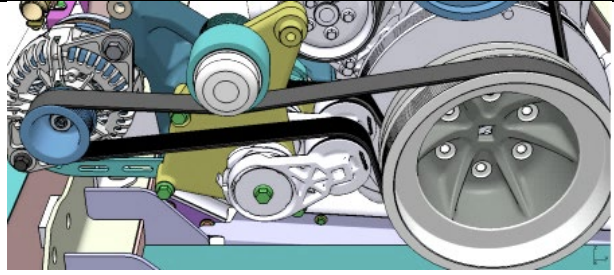


FIGURE 70

60. Remove former belt routing decal and replace with **decal #010060**.

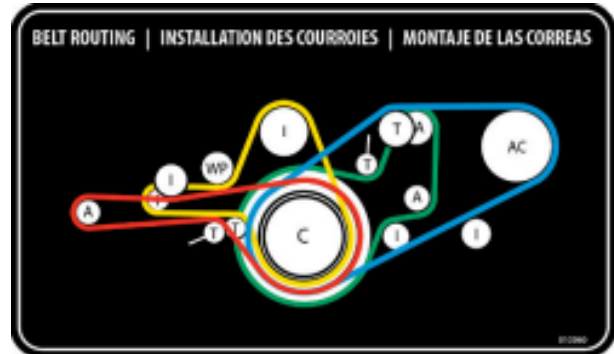


FIGURE 71

61. On the alternator, install the stud adapter **#060297** at **B1+** stud terminal.

**torque: 11 lbf-ft**

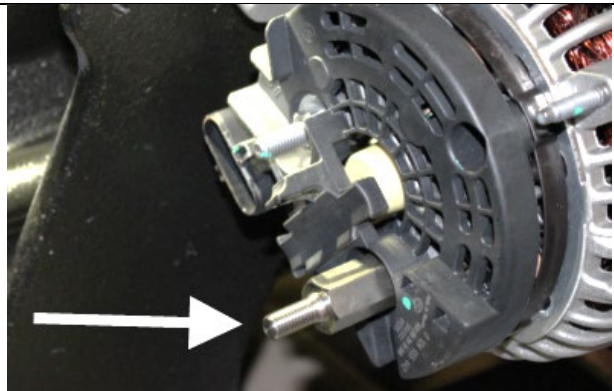


FIGURE 72

62. Perform the “Multiplex Modules Disconnection Procedure Prior to Welding” found in your vehicle Maintenance Manual, Section 00: General.

63. Weld the new coolant filter support **#050265** on the engine cradle.

**23 1/2 inches (597 mm) from the end of the cradle**

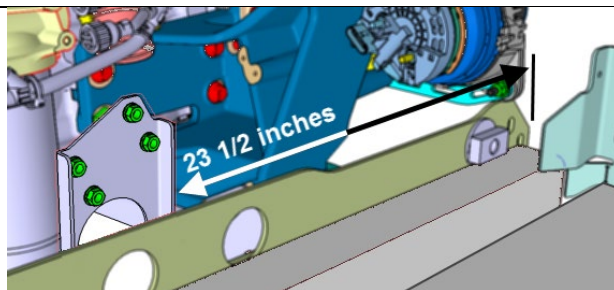


FIGURE 73

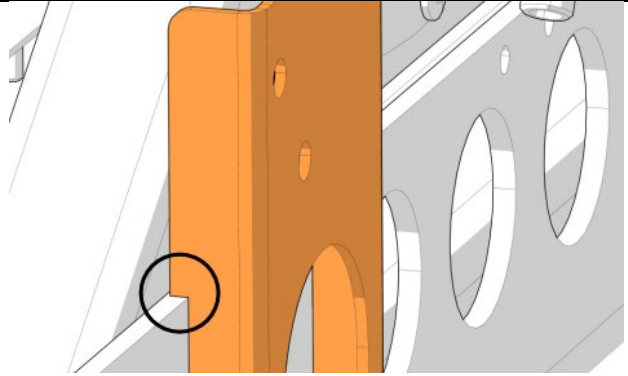


FIGURE 74

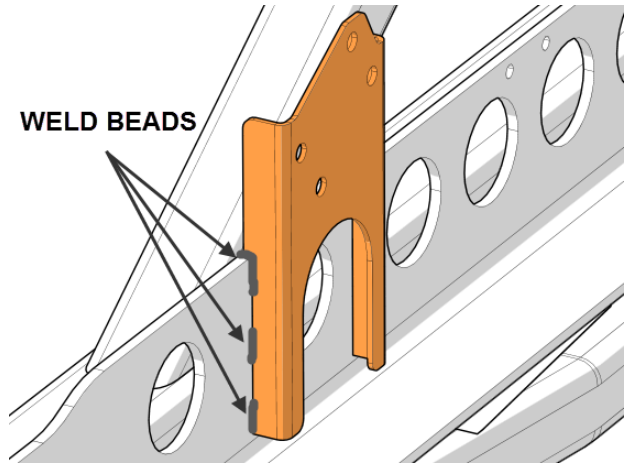
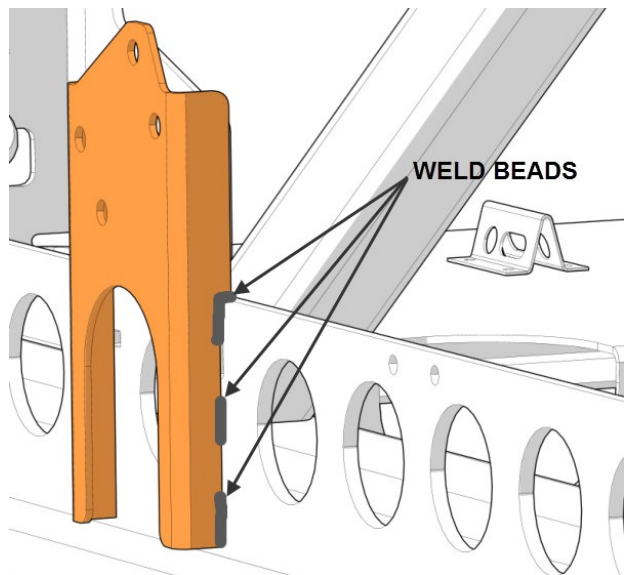


FIGURE 75



64. As a preparation for **welding**, use a grinder with abrasive disc to remove some paint to reach bare metal. Weld the **ground stud** #380360 centered on the beam, at 16 inches (406 mm) from the vertical member beam end.

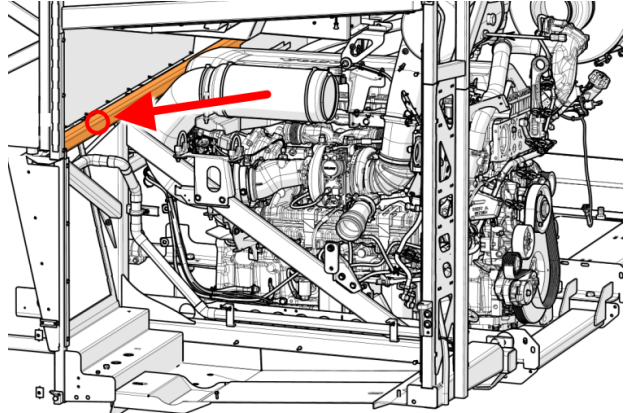


FIGURE 76

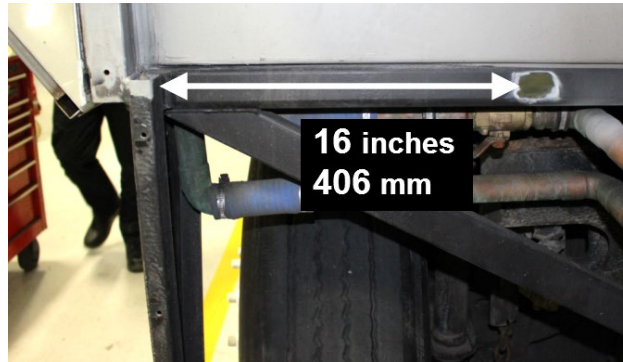


FIGURE 77

65. Apply black paint to the area surrounding the ground stud and the ground stud circular base. **DO NOT** apply paint on the electrical contact surfaces.



FIGURE 78: GROUND STUD #380360



FIGURE 79: GROUND STUD #380360

66. Install a tie mount #509490 with one screw #502686 at the back of the L.H. engine mount.



FIGURE 80

67. Install the alternator ground cable #069504. Secure to the ground stud on the alternator using washer #502573 and nut #5001182.

**torque: 6 lbf-ft**

68. Secure the alternator ground cable to the previously installed tie mount using one nylon tie #509491.



FIGURE 81

69. Secure the alternator ground cable #069504 to the previously installed ground stud on the L.H. engine mount.

**Use screw #502719 & washer #5001935**

**torque: 20 lbf-ft**

**Protection against corrosion. Apply Color Guard rubber coating on the ground stud once the ground cable is hooked up.**

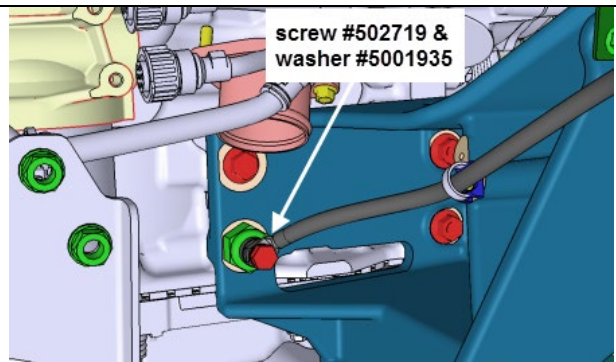


FIGURE 82

70. To the previously installed coolant filter support, install the filter holder recovered from the former installation.

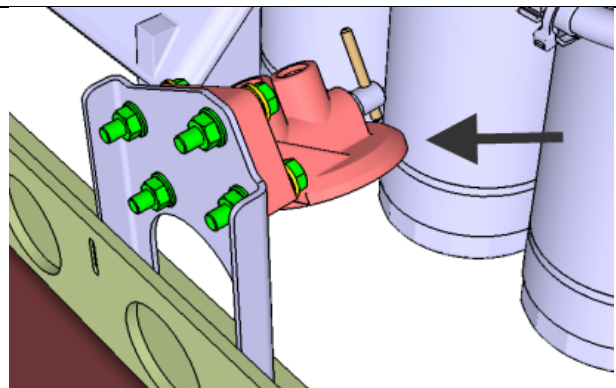


FIGURE 83

71. Install the new coolant filter included in the kit onto the filter holder. Check the clearance between the filter and the near hose clamps of the coolant pipe leading to the transmission oil cooler.

72. Transfer the drain plug and the coolant extractor quick connect fitting saved from the old radiator outlet pipe.

**Apply Loctite 567 Thread Sealant prior installation of the fittings**

73. Install the new radiator outlet pipe #050331. Reinstall with the flexible hose #053617 and four (4) hose clamps #992089. Use steel wire to hold the end of the pipe until the radiator is installed if required.

**A: # 992089 hose clamp (4x); torque: 30 lbf-in**

**B: drain plug**

**C: coolant extractor quick connect valve**

**D: # 053617 silicone hose**

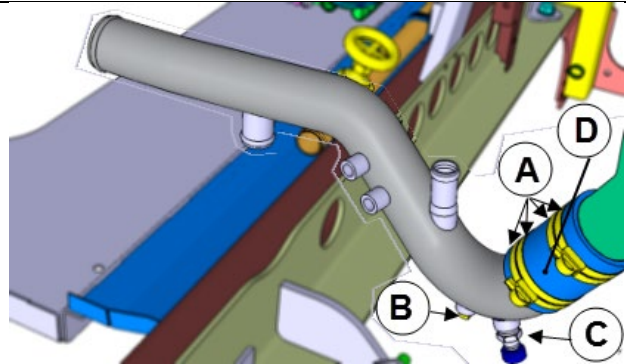


FIGURE 84

74. Connect the elbow between the copper heater line and the new radiator outlet pipe.

**A: #992086 hose clamp (1x)**

**For proper clamp torque, refer to HOSE CLAMP TORQUE on page 14.**

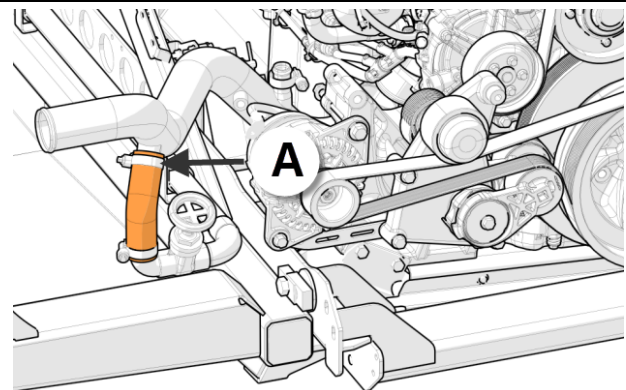


FIGURE 85

75. Using blue flexible hose #052366, prepare two new short hoses for the coolant filter.
- Cut two sections of blue flexible hose, one **13 inches** long and a second one, **24 inches** long.
  - Use the banjo fittings **recovered** from the previous installation.

**A : hose clamp #992081 (4x)**

**B: banjo fitting copper washer #507657 (6x)**

**hose clamp torque: 30 lbf-in**

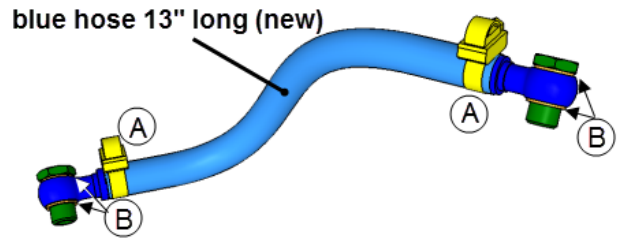


FIGURE 86

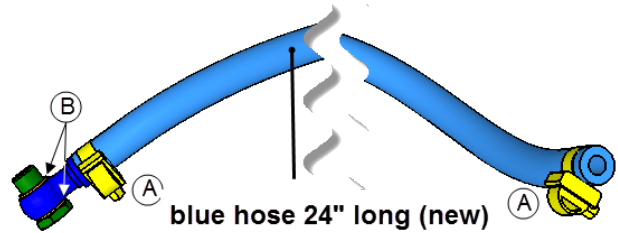


FIGURE 87

76. Install the 13" and 24" long hoses prepared at the previous step as shown on the images.

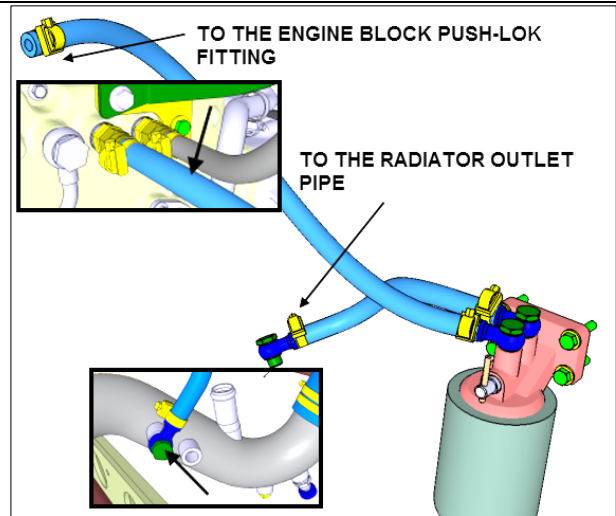


FIGURE 88

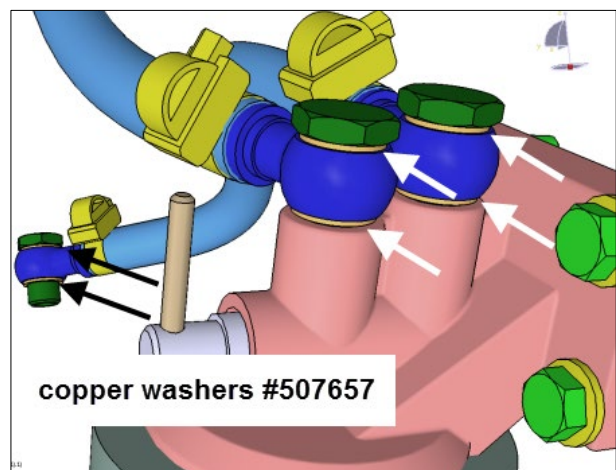


FIGURE 89

77. Secure the 24" long hose as shown on the image.

**A : nylon tie # 509491**

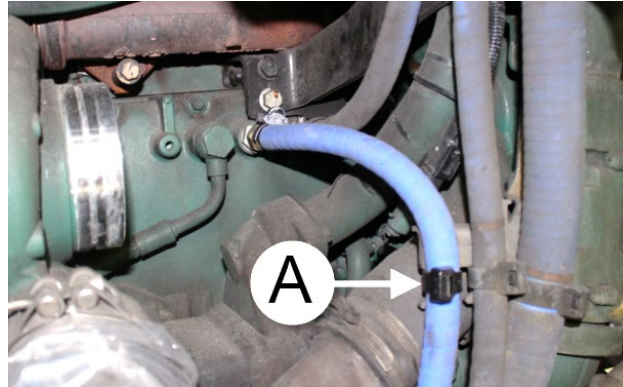


FIGURE 90

78. Connect the DEF injector coolant line return hose to the radiator outlet pipe.

**Use two (2) new banjo fitting copper washer #507657**

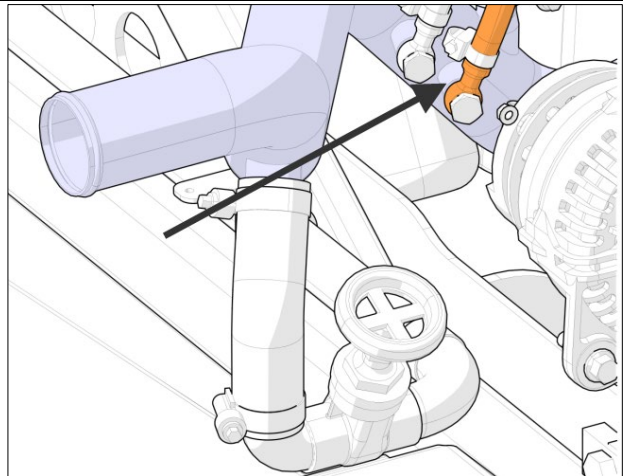
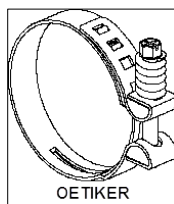


FIGURE 91: DEF INJECTOR COOLANT LINE RETURN HOSE

79. Connect the coolant line that comes from the surge tank to the radiator outlet pipe. Use one (1) hose clamp #992086.



CONSTANT TORQUE



OETIKER



CAILLAU

**TORQUES:**

**Caillau clamps : 30 lbf-in**

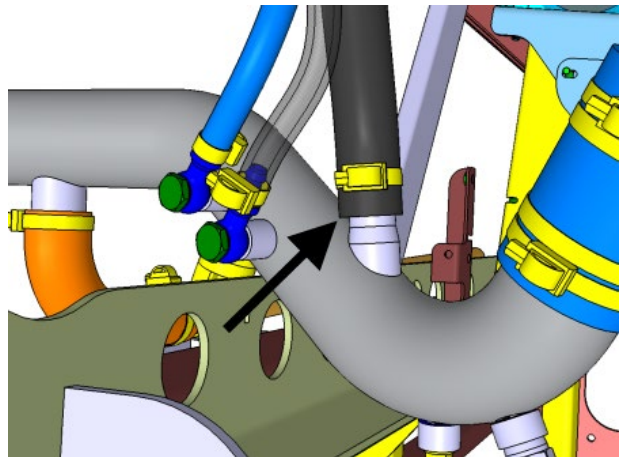


FIGURE 92

80. Secure the coolant hoses together using the following hardware.

**A** : nylon tie # 509491 (2x)

**B**:swivel mount #504751 (1x)

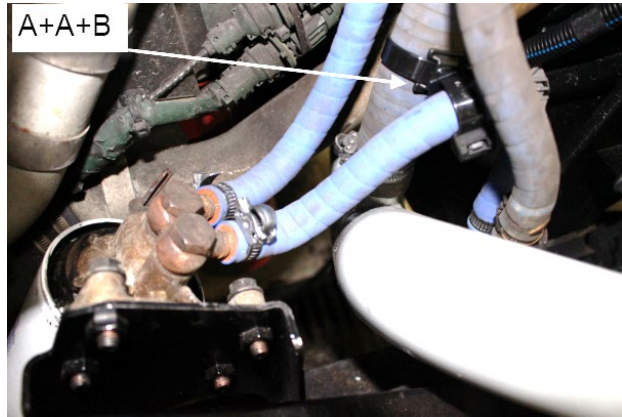


FIGURE 93

81. Secure the coolant hoses together using nylon ties.

**A**: « handcuff » nylon tie #N37749 (2x)

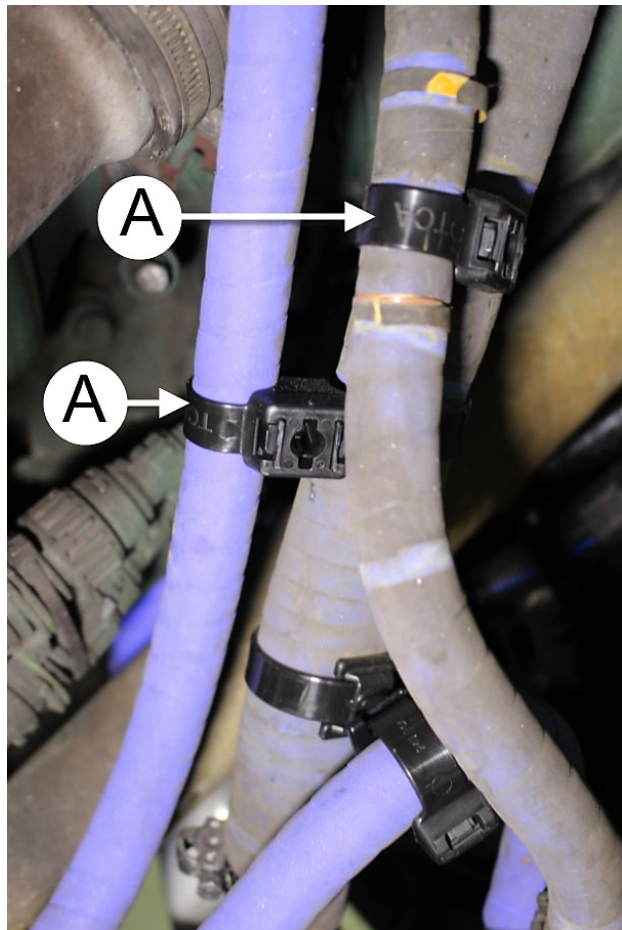


FIGURE 94

82. Hang the engine intake pipe #050308 in place.

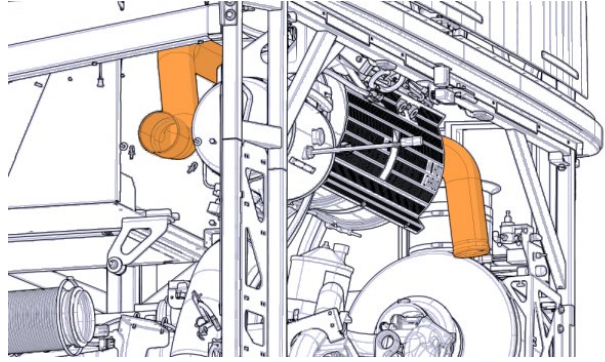


FIGURE 95



FIGURE 96: ENGINE INTAKE PIPE SUPPORT

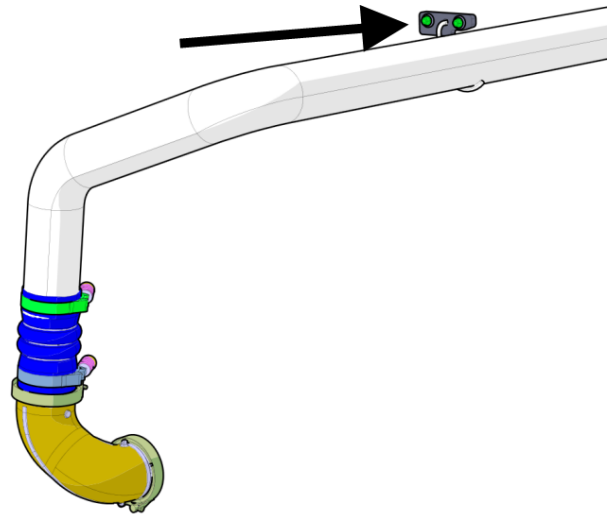
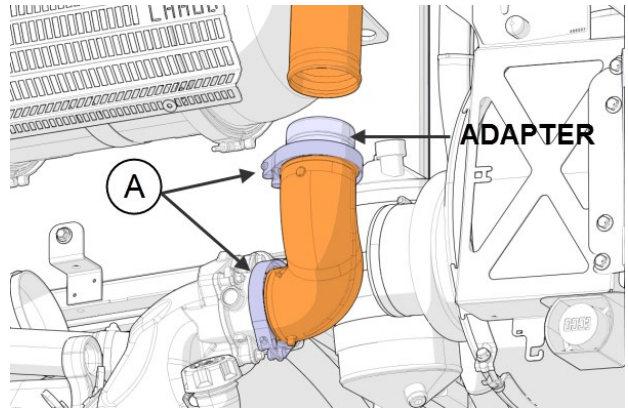


FIGURE 97: PIPE SUPPORT

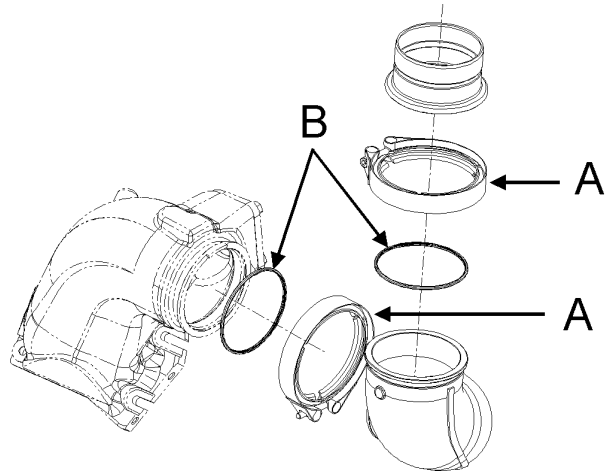
83. Reinstall the intake elbow and adapter. Use the following hardware:

**A: V-band clamp #20592783 (2x)**

**B: Gasket #1675066 (2x)**



**FIGURE 98: ENGINE INTAKE PIPE SUPPORT**



**FIGURE 99**

84. Connect the new CAC outlet pipe #050308 to the engine intake elbow.

**A: #030096 hose (1x)**

**B: #21490630 spring loaded clamp (2X)**

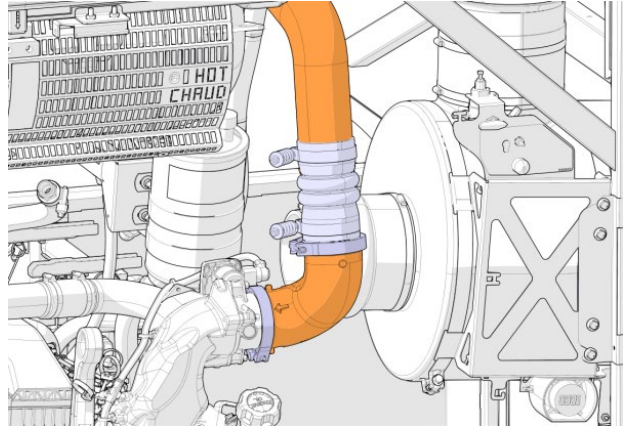


FIGURE 100

**Constant Torque hose clamp 4.25" - charge air cooler (CAC) 4.5-5.5 lbf-ft**

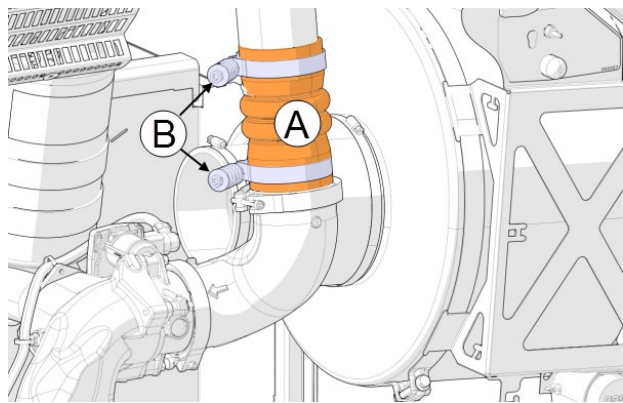


FIGURE 101: CONNECTION AT THE ENGINE INTAKE ELBOW

85. Reinstall the pipe (item A) section located downstream the engine air filter. Connect the air compressor fresh-air inlet pipe (item B) connected to pipe A.

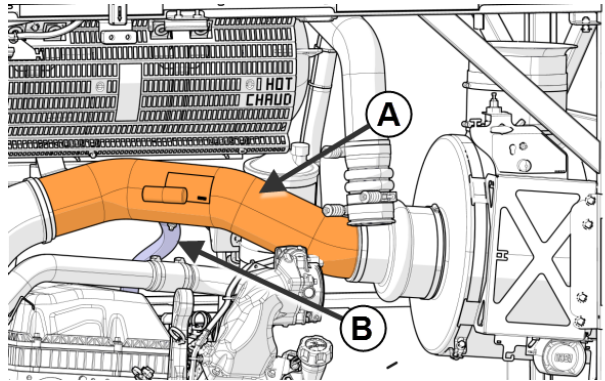
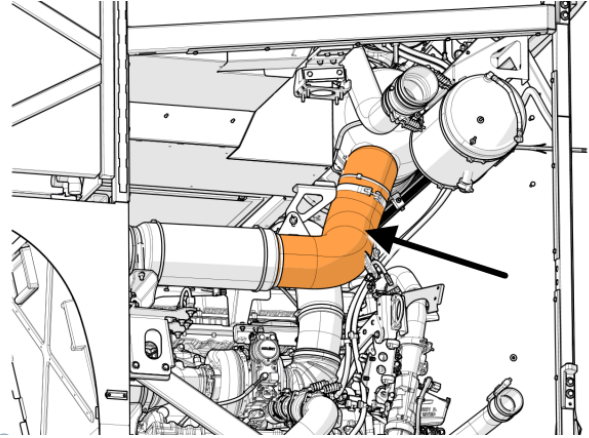


FIGURE 102

86. Reinstall the exhaust pipe section located between the DPF and the flexible section. Use the following hardware:

- **V-band clamp #21021850 (2x)**
- **Gasket #21095726 (2x)**

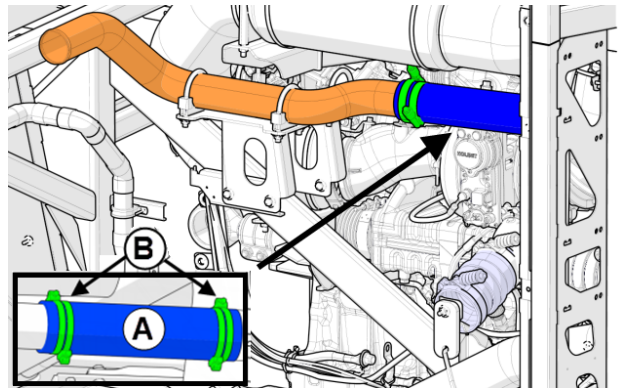


**FIGURE 103: REINSTALL THIS EXHAUST PIPE SECTION**

87. Pre-install the new radiator inlet pipe #050309.

**A: #052889 silicone hose**

**B: # 992089 hose clamp (4x); final torque: 30 lbf-in**



**FIGURE 104**

88. Install **seven (7) nylon tie mounts** centered on the beam, as shown in the picture. Drill  $\varnothing$   $\frac{1}{4}$ ". Use the following hardware:

- **Tie mount #509490 (7x)**
- **Rivet #504610 (7x)**

**Spacing between each tie mount: around 6  $\frac{1}{2}$ "**

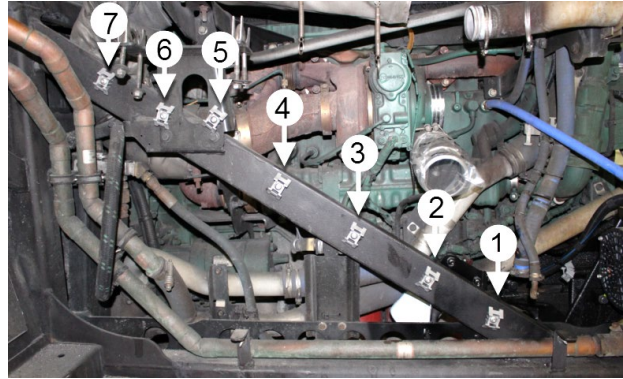


FIGURE 105

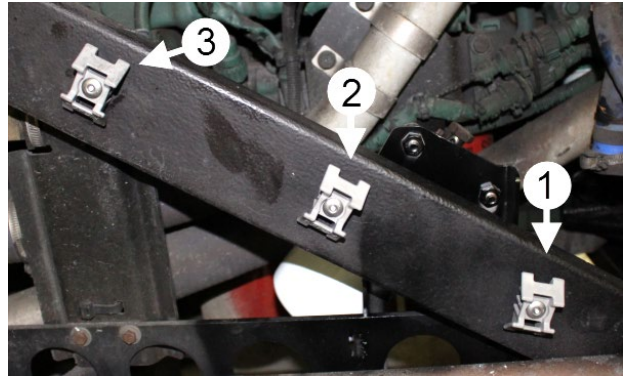


FIGURE 106

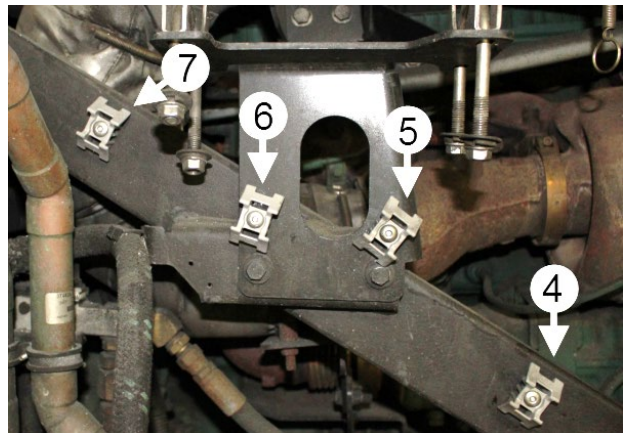


FIGURE 107

89. Install **five (5) nylon tie mounts** as shown in the picture. Drill  $\text{\O} \frac{1}{4}$ ". Use the following hardware:

- **Tie mount #509490 (5x)**
- **Rivet #504610 (5x)**

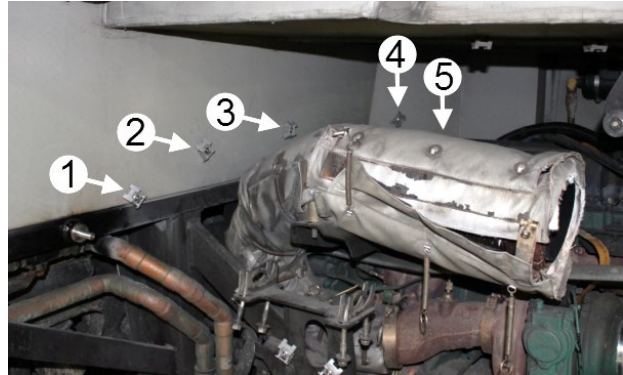


FIGURE 108

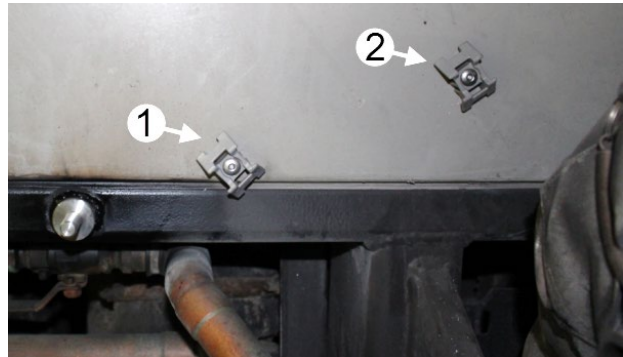


FIGURE 109



FIGURE 110: TIE MOUNT 3 & 4 SHALL NOT BE PLACED BETWEEN THE BULKHEAD AND THE VALVE COVER.

90. On the bracket shown on the image, drill a hole of  $\text{\O} \frac{11}{32}$ " and then install a nylon tie with fir tree mount **#504750**.

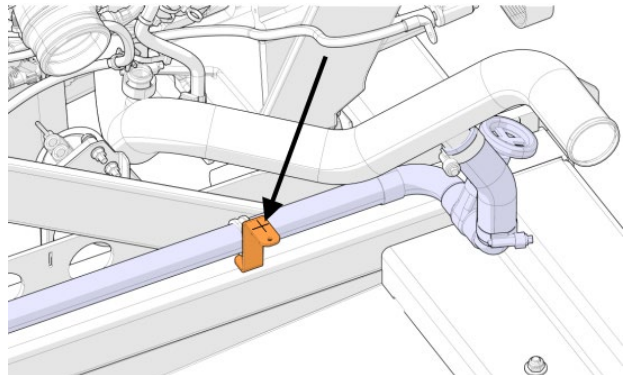


FIGURE 111: BRACKET ON THE ENGINE HOT SIDE

91. Hook up the “L.H. alternator power cable» #060682 to the alternator (+) terminal which is the stud adapter.

**A: nut M8 #5001983 torque: 11 lbf-ft**

**B: flat washer #5001341**

**C: nylon tie #504016 (2x)**

**D: tie mount #504013 (2x)**

**E: rivet #504379 (2x)**

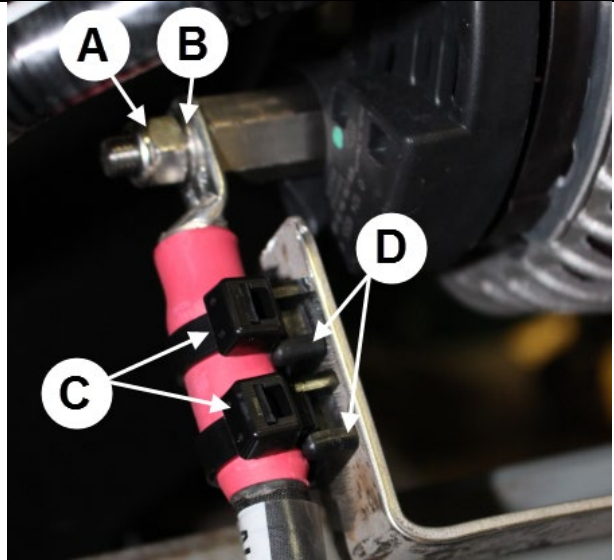


FIGURE 112

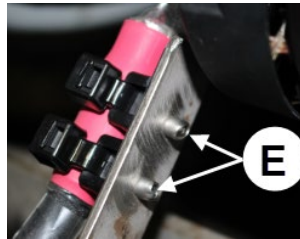


FIGURE 113

92. Secure the alternator power cable to the tie mounts previously installed using nylon ties:

- **nylon tie #509491 (7x)**



FIGURE 114

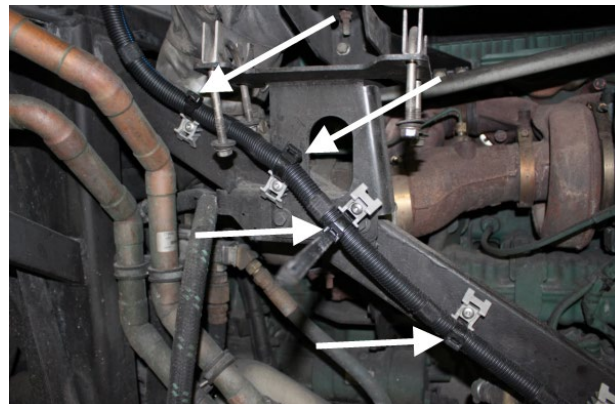


FIGURE 115

93. On the diagonal member located under the previously welded ground stud, install a nylon tie mount. Use:

- **Tie mount #509490 (1x)**
- **Rivet #504610 (1x)**

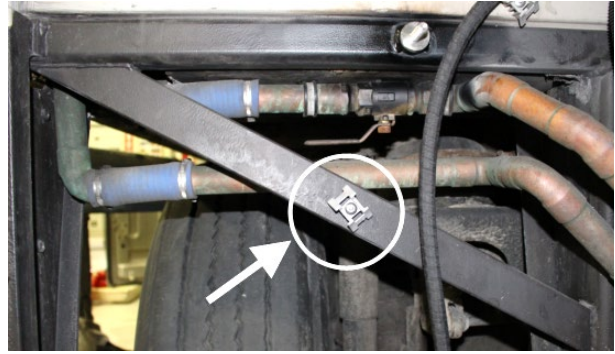


FIGURE 116

94. Partially install the “fan drive power cable” #069245. Secure to the tie mount using a nylon tie. Keep the nylon tie loose.

**DO NOT TIGHTEN THE NYLON TIES AT THIS  
MOMENT**

**A: nylon tie #509491 (1x)**

**B: fan drive power cable #069245**

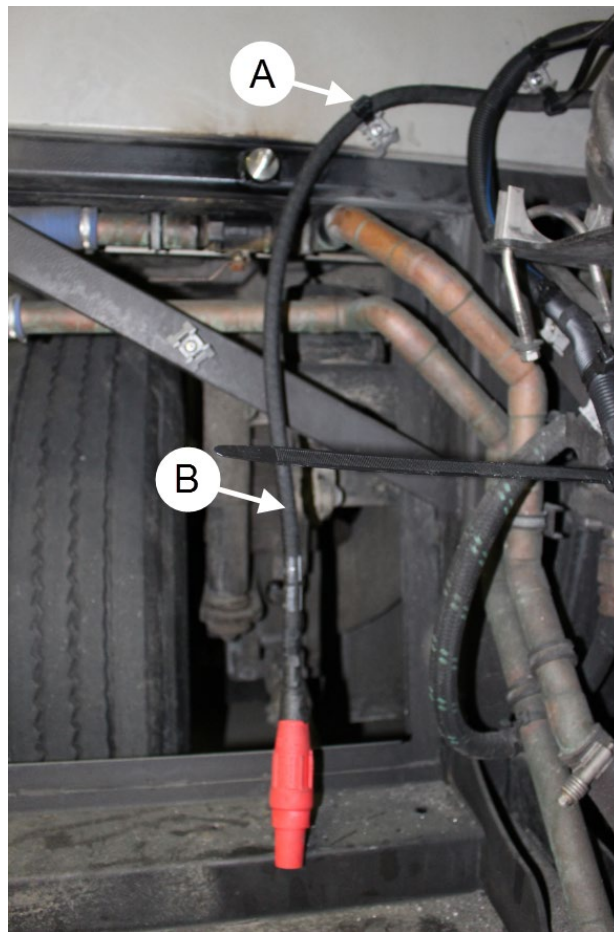


FIGURE 117

95. Install the “fan drive ground cable” #069246 and connect to the ground stud previously welded to the chassis.

**DO NOT TIGHTEN THE NYLON TIES AT THIS MOMENT**

**A: fan drive ground cable #069246**

**B: fan drive power cable #069245**

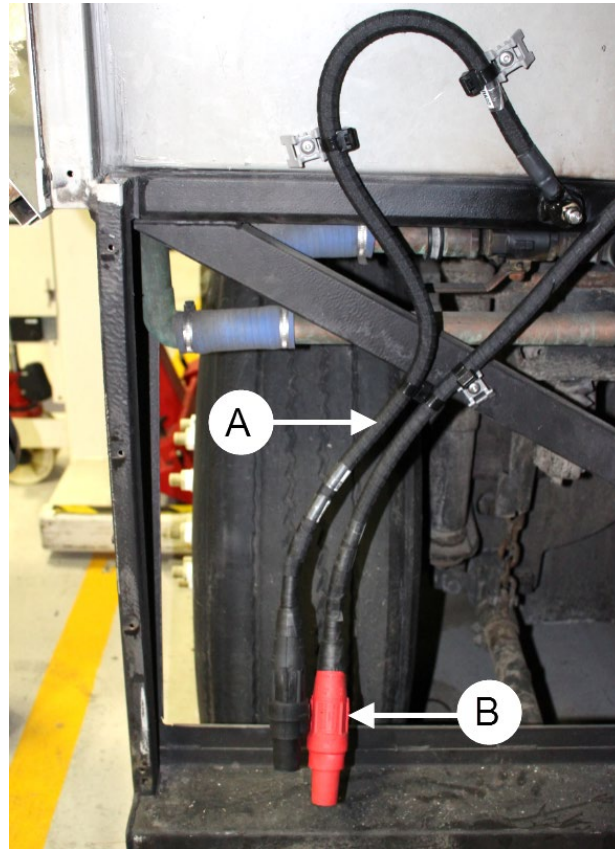


FIGURE 118

**C: split lock washer #500482 + brass nut #500998**  
**D: tie mount #509490 (1x) + rivet #504610 (1x) + nylon tie #509491 (1x)**

**DO NOT TIGHTEN THE NYLON TIES AT THIS MOMENT**

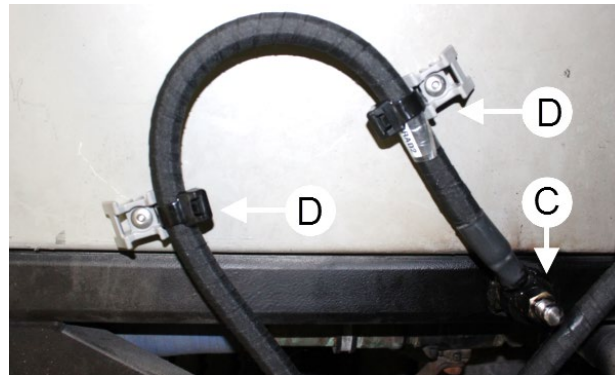


FIGURE 119

**A: fan drive ground cable #069246**

**B: fan drive power cable #069245**

**D: tie mount #509490 (1x) + rivet #504610 (1x) + nylon tie #509491 (1x)**

**E: « handcuff » nylon tie #N37749 (1x)**

**DO NOT TIGHTEN THE NYLON TIES AT THIS MOMENT**

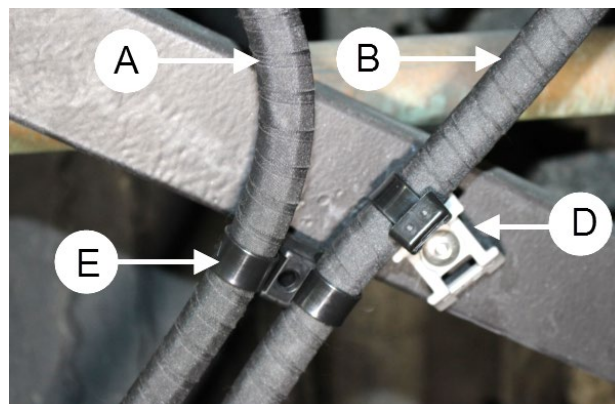


FIGURE 120

96. When stretched, the end of the ground cable and the fan drive power cable connector should be at approximately  $1\frac{1}{2}$ " to  $2\frac{1}{4}$ " (38 mm to 57 mm) from the lower flat surface.
97. Once properly adjusted, tighten the nylon ties previously installed.

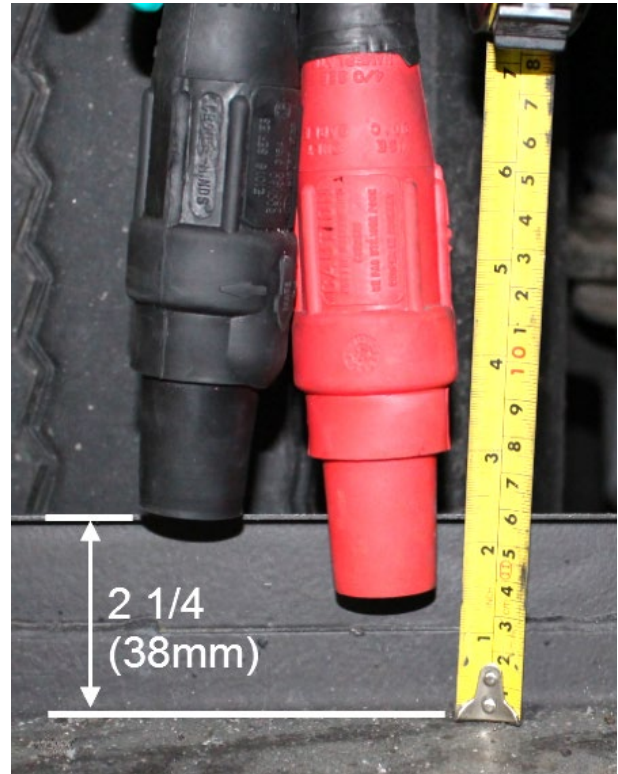


FIGURE 121

98. Apply Loctite Color Guard Rubber Coating on the ground stud connection.



FIGURE 122: GROUND STUD WITH RUBBER COATING

---

**99. INSTALLATION OF THE ALTERNATOR CONTROL CABLE #069511**

- a) Connect the harness #069511 to the alternator.
- b) Secure the harness with nylon ties as shown on the pictures.



**FIGURE 123: C: NYLON TIES #504016 (2x)**

100. Partially route the "alternator control cable" #069511 along the "alternator power cable" as shown on the images. Secure the "alternator control cable" on the "alternator power cable" using nylon ties.

**A:** nylon tie #504016 (9x)

**B:** « handcuff » type nylon tie #N37749 as required

**NOTE:** The "alternator control cable" #069511 will be connected to the "fan to RJB interface" harness #23488790. For this reason, do not route the "alternator control cable" further than what is shown on the images.

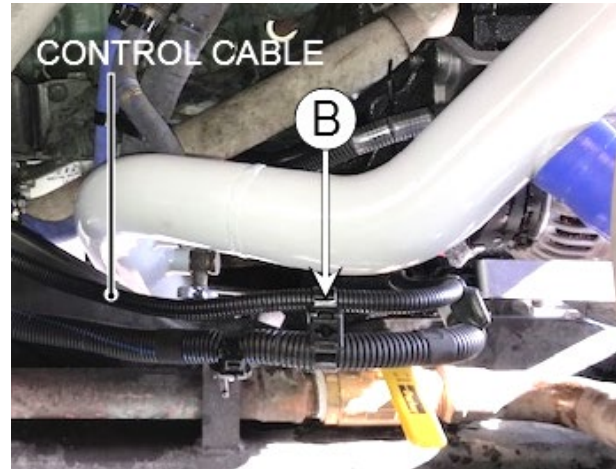


FIGURE 124

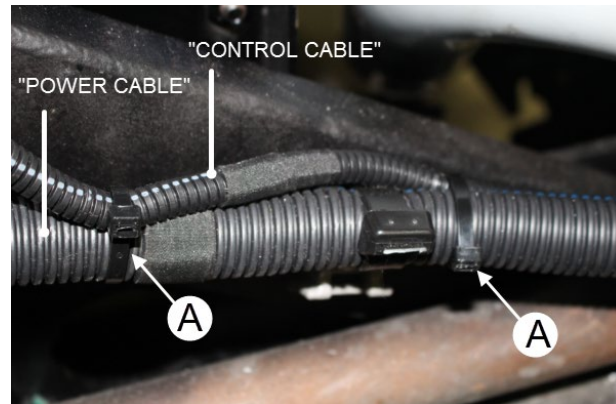


FIGURE 125

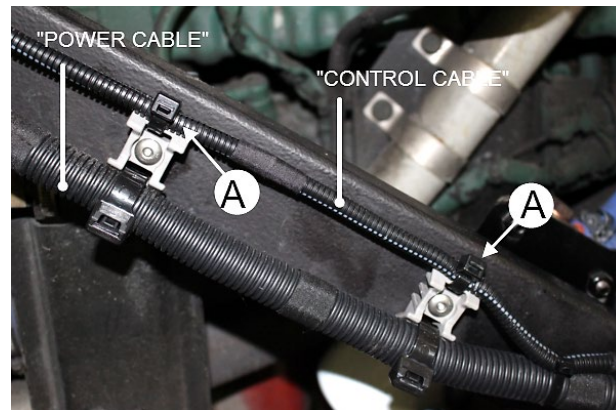


FIGURE 126

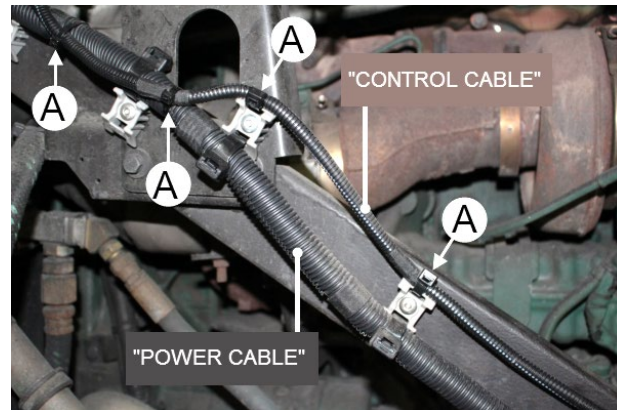


FIGURE 127



FIGURE 128

101. Route the **“fan drive power cable”** and the **“alternator power cable”** up to the electrical compartment.

DO NOT PASS THE CABLES through the upper cable boot AT THIS MOMENT. Refer to the pictures at right as a guide for the installation.

Secure both cables with the four (4) tie mounts previously installed. Secure the cables on the tie mounts as previously done with nylon ties.

**A: nylon tie #509491 (8x)**

**DO NOT TIGHTEN THE NYLON TIES AT THIS MOMENT**

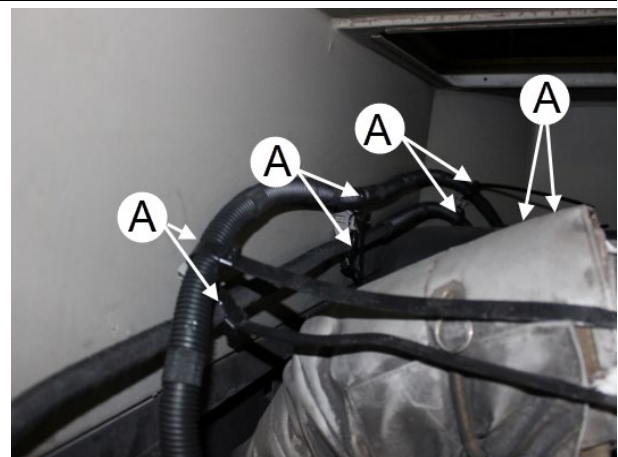


FIGURE 129

102. Route the “fan to RJB interface harness” #23488790 up to the electrical compartment, passing through the upper cable boot. But first, place connector A34-J1 next to the red connector of the fan drive power cable (see image at right).

**A: fan to RJB interface harness #23488790**

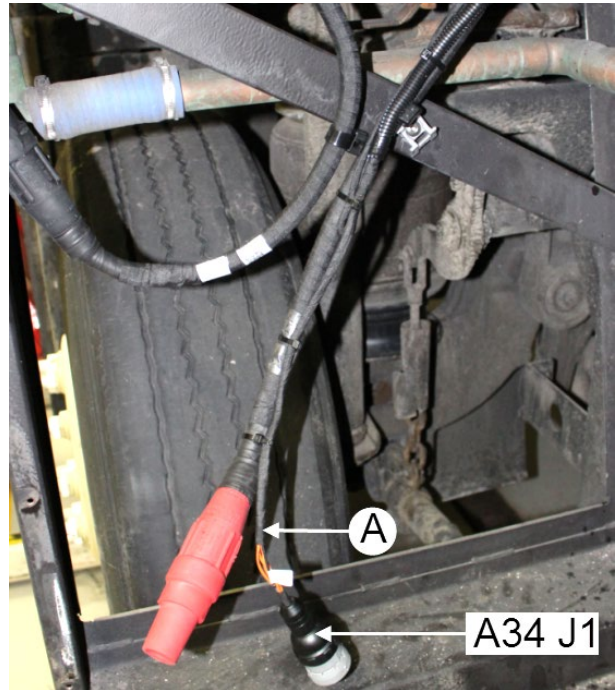
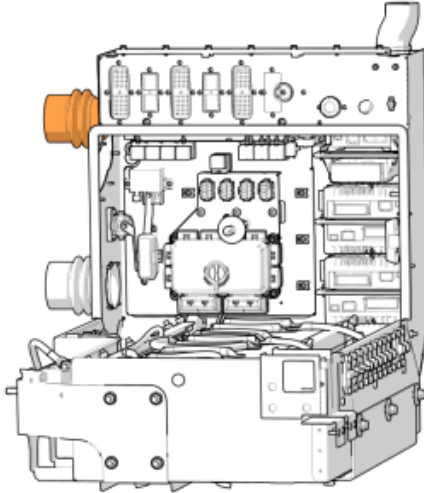


FIGURE 130

103. Secure harness #23488790 along the fan drive power cable, placing a nylon tie #504016 every 6 inches (150 mm).

**DO NOT TIGHTEN THE NYLON TIES AT THIS MOMENT**



FIGURE 131

104. Secure connector C-ALT3 as shown on the image with one (1) nylon tie #504016 and then connect to the alternator control cable #069511 previously installed.

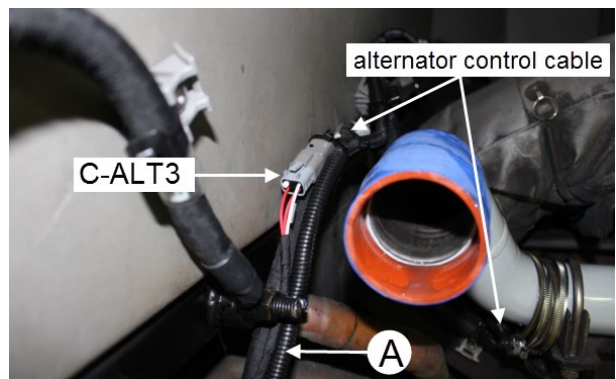
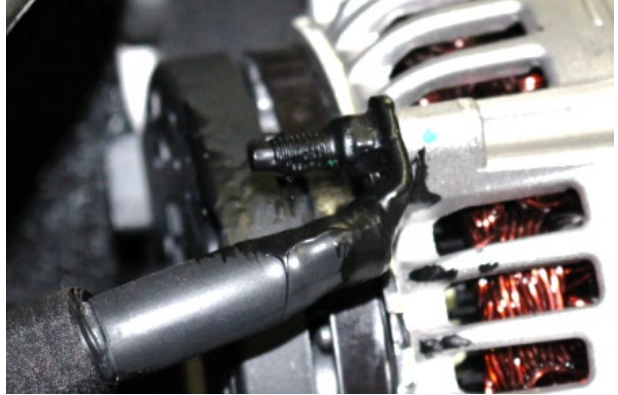


FIGURE 132

105. Apply Color Guard rubber coating at the alternator ground ( $\perp$ ) and positive (+) connections.



**FIGURE 133: GROUND CONNECTION ON THE ALTERNATOR**



**FIGURE 134: POSITIVE (+) CONNECTION ON THE ALTERNATOR**

106. Pre-install the new **CAC inlet pipe #050328**. Use one new #030096 CAC flexible hose. Secure the hose using two (2) spring-loaded clamps #21490630.

- #030096 hose (1x)
- #21490630 spring loaded clamp (2X), final torque: 5 lbf-ft

**NOTE: On vehicles prior serial G-5932 (2016), remove the 90° elbow diffuser pipe and replace with straight turbo diffuser pipe #053662. Use the following parts:**

- A: straight turbo diffuser pipe #053662 (1x)**
- B: gasket #21096684 (1x)**
- C: V-band clamp #20592787 (1x)**

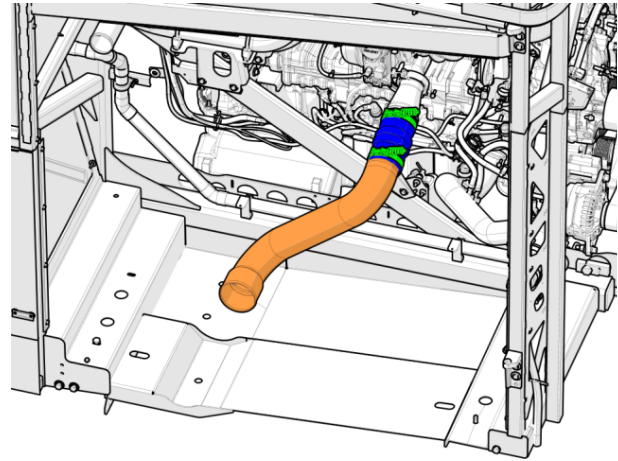
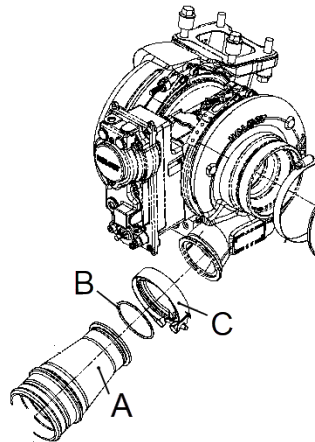


FIGURE 135: CONNECTION AT THE TURBO OUTLET ELBOW

107. Preinstall all the flexible hoses at the cooling pack connections. Use the following parts:

- A: flexible hose #531469 (1x)**
- B: flexible hose #531471 (1x)**
- C: silicone hose #053617 (2x)**
- D: clamp #21490616 (8x)**
- E: caillau clamp #992089 (8x)**

**For proper clamp torque, refer to HOSE CLAMP TORQUE on page 14**

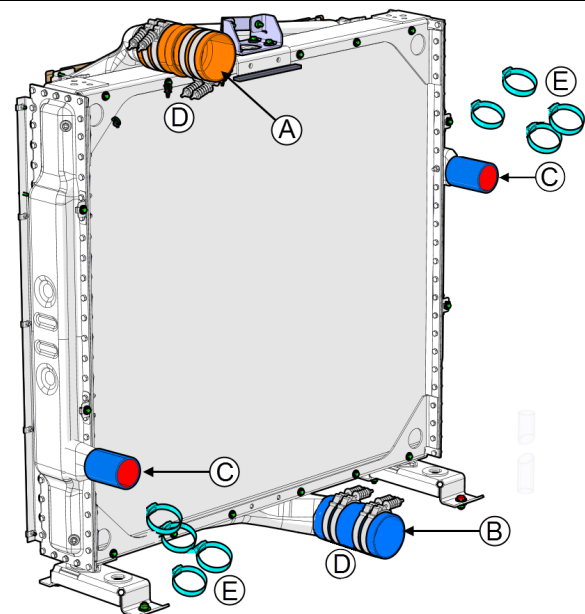


FIGURE 136

108. Prepare the **cooling pack upper attachment** with the three (3) rectangular plates (see image) recovered from the former installation and the following parts:

**A: anti-vibration mount #21185073**

**B: upper radiator support #050351**

**C: 2x screw #5001738 , 2x nut #502837**

**D: 2x screw #5001738 , 2x washer #500942**

**E: 2x screw #5001745 , 2x washer #500942**

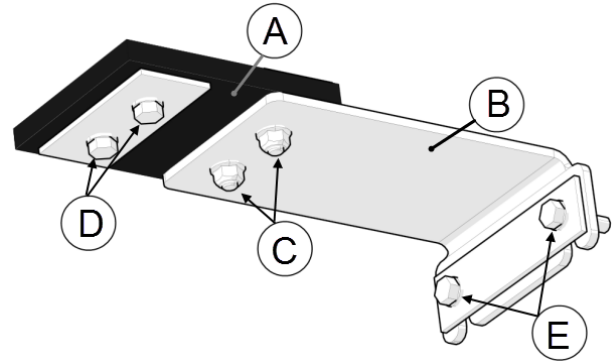


FIGURE 137:

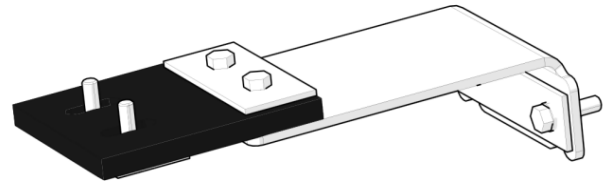


FIGURE 138

109. Install the upper attachment on the cooling pack.

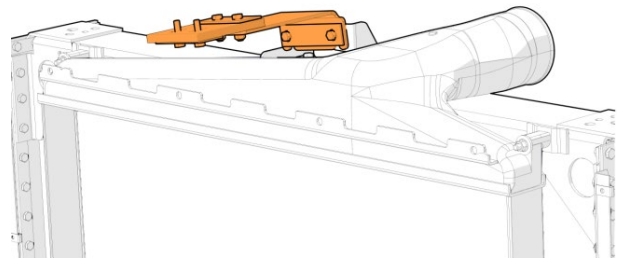


FIGURE 139

110. Reinstall the cooling pack in its compartment.

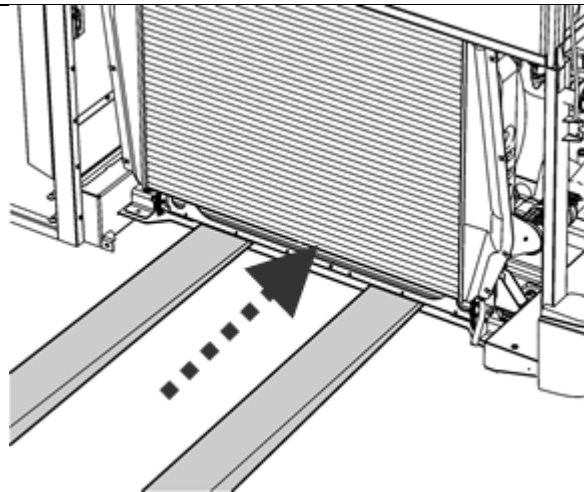


FIGURE 140

111. Secure the cooling pack base with the following parts:

**A: 4x screw #502804**

**B: 8x washer #5001751**

**C: 4x nut #502859**

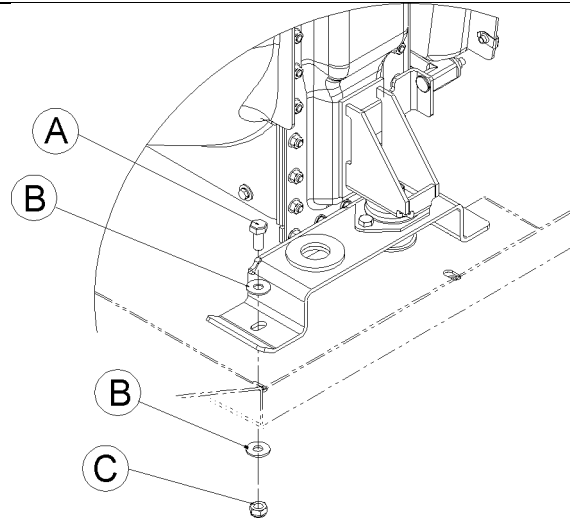


FIGURE 141

112. Bolt the anti-vibration mount onto the vehicle chassis

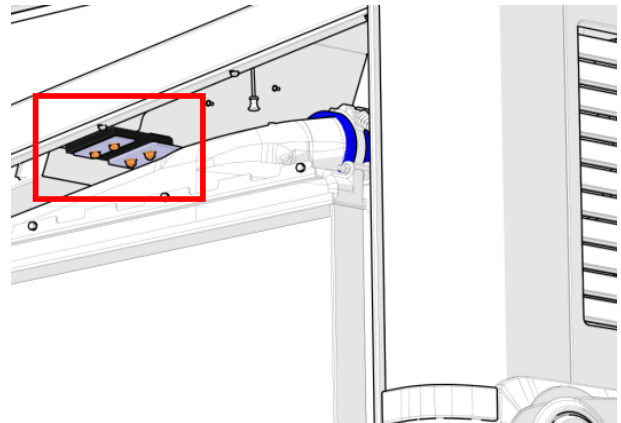


FIGURE 142

113. Complete the connection with the cooling pack.

*For proper clamp torque, refer to HOSE CLAMP TORQUE on page 14*

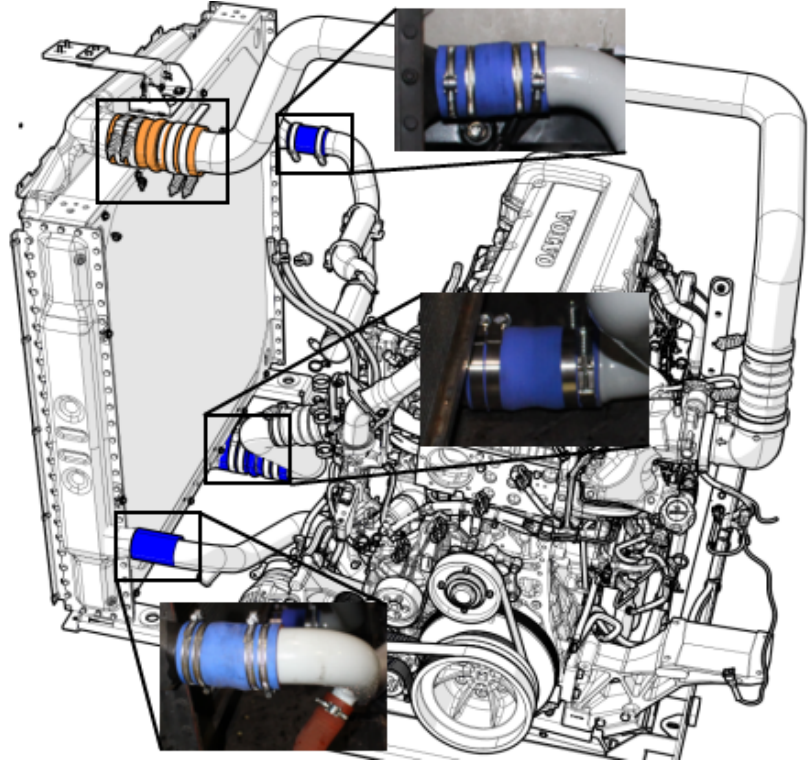
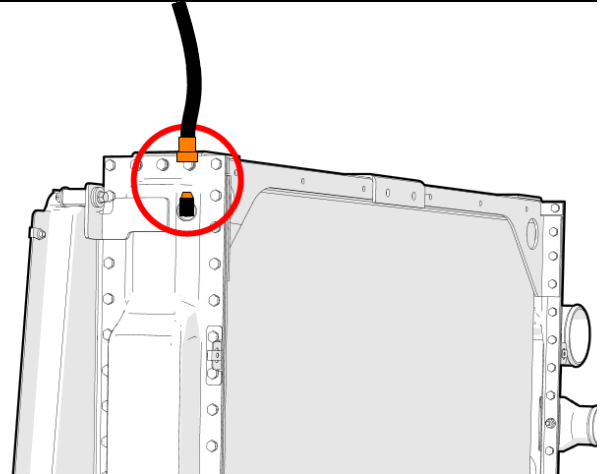


FIGURE 143

114. Connect the **radiator vent hose** on top of the radiator.



115. Reinstall the cooling pack protector tube with the following hardware:

- A: Screw #502804 (3x)**
- B: split lock washer #5001737 (3x)**
- C: flat washer #5001751 (2)**

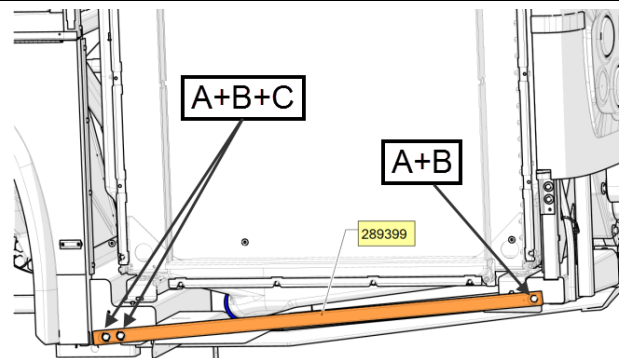


FIGURE 144

116. Remove all the old spring nuts on the cooling pack and replace with new spring nuts.

- **spring nut #5001965 (18x)**

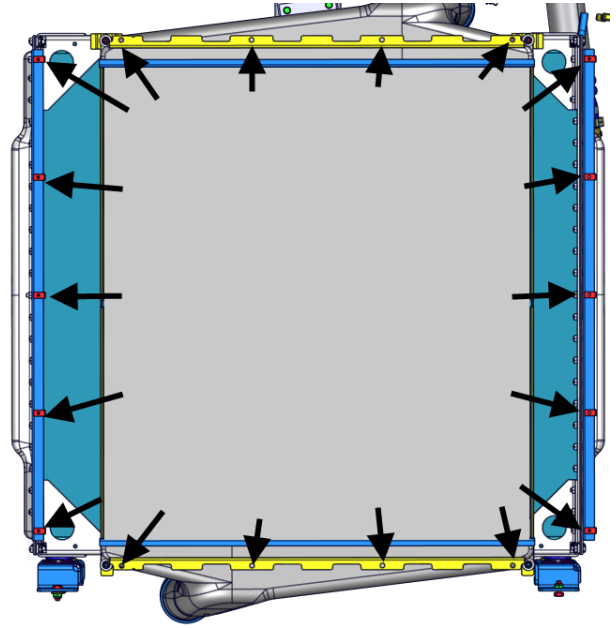


FIGURE 145

117. Install the sealing element #050355. Secure with the following hardware:

**4x bolt #5001697**

**4x lock washer #502570**

**Use foam tape #506040 to fill the gap between the sealing element and the charge air cooler if necessary.**

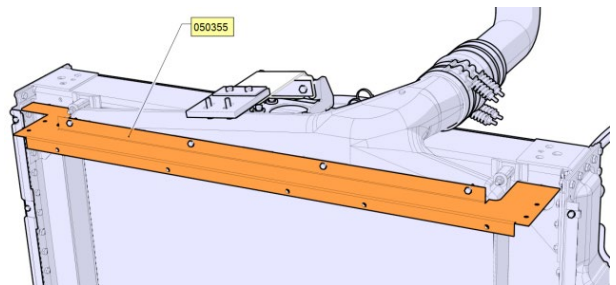


FIGURE 146

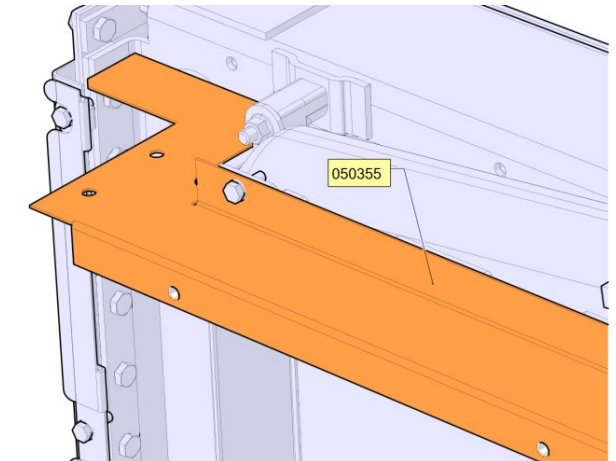


FIGURE 147

118. Install the sealing element **#050362**. Screw it on the existing threaded holes on the bottom of the radiator. Secure with the following hardware:

**4x bolt #5001697**

**4x lock washer #502570**

**Use foam tape #506040 to fill the gap between the sealing element and the charge air cooler if necessary.**

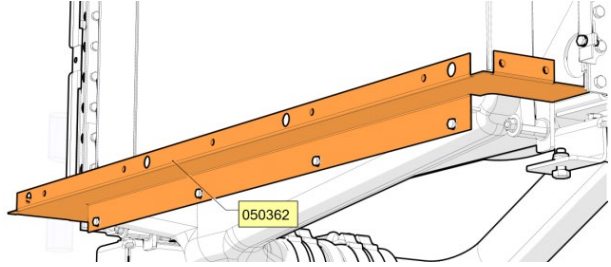


FIGURE 148

119. Install the sealing element **#050360**. Screw them onto the upper and lower sealing elements installed at the previous steps. Secure with the following hardware:

**9x bolt #5001697**

**9x lock washer #502570**

**A: #050360**

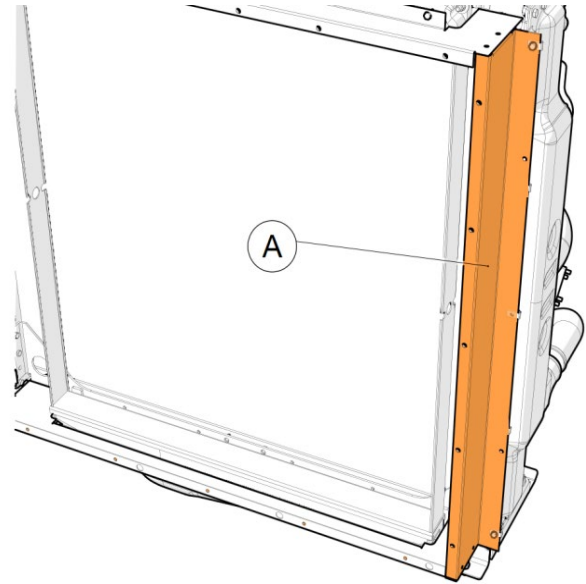


FIGURE 149

120. Install the sealing element **#050380**. Secure with the following hardware:

**5x bolt #5001697**

**5x lock washer #502570**

**B: #050380**

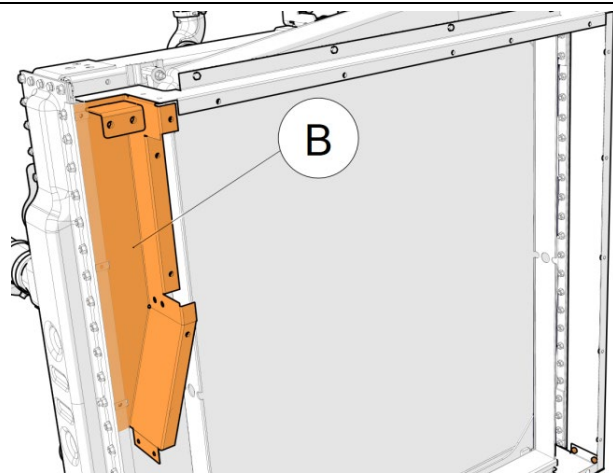


FIGURE 150

121. Install the sealing element **#050359**. Secure with the following hardware:

**6x bolt #5001697**

**6x lock washer #502570**

**C: #050359**

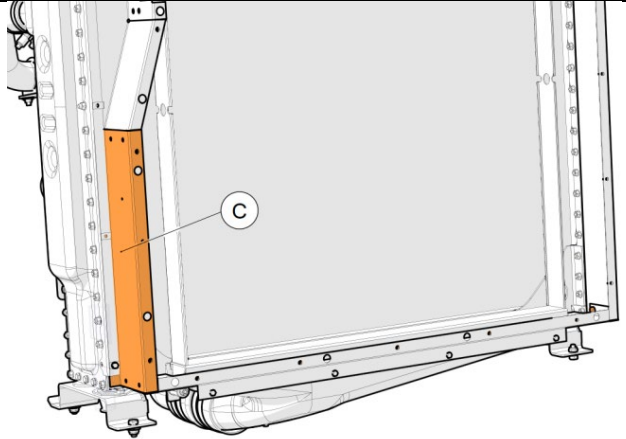


FIGURE 151

122. Cut two pieces of 39 <sup>3</sup>/<sub>8</sub> inches (1000 mm) long of **rubber extrusion #506025**.
123. Using good industrial glue (Loctite 404 or similar product), glue the two pieces of rubber extrusion centered on the reinforcement angles of fan support panel **#050343**.



FIGURE 152

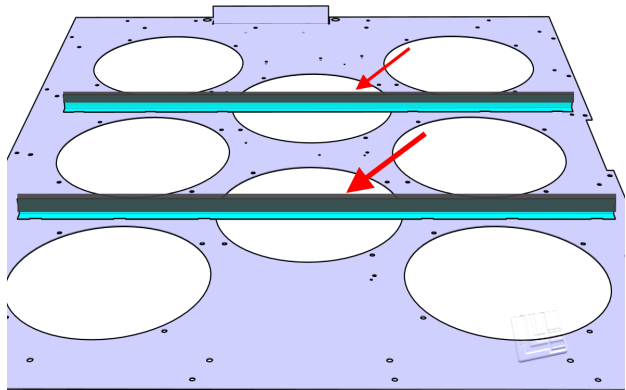


FIGURE 153

124. Install panel **#050343**. Secure with the following hardware:

**22 x bolt #5001697**

**22 x lock washer #502570**

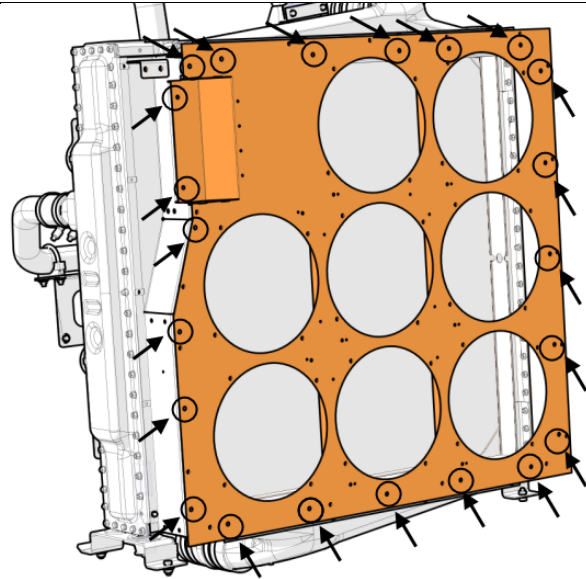


FIGURE 154

125. Install the circuit breaker box **#564612**.

Install with the following hardware:

**4x bolt #500119**

**4x lock washer #5001868**

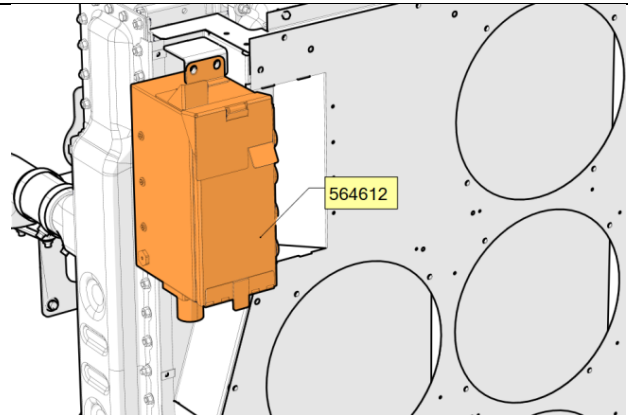


FIGURE 155

126. Install the upper sealing element **#050366**.

Secure with the following hardware:

**5x bolt #5001697**

**5x lock washer #502570**

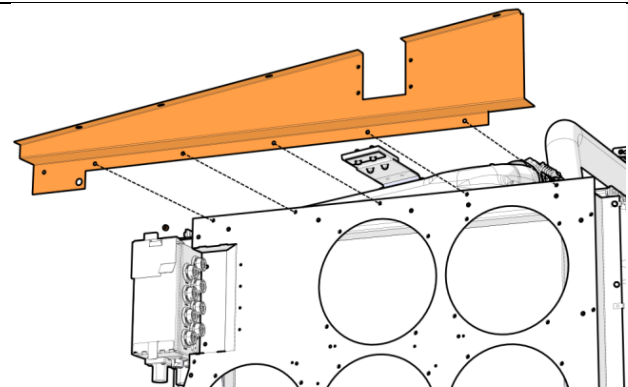


FIGURE 156

127. Install the pull-rod box #050369.  
Secure with the following hardware:  
**4x bolt #5001697**  
**4x lock washer #502570**

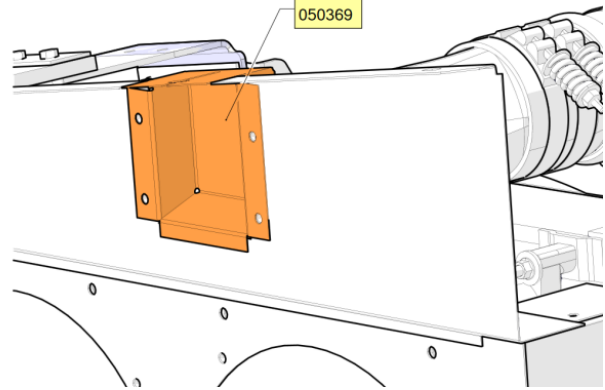


FIGURE 157

128. Install the lower sealing element #050365.  
Secure with the following hardware:  
**4x bolt #5001697**  
**4x lock washer #502570**

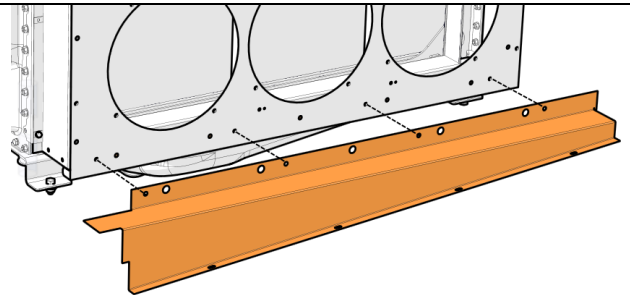


FIGURE 158

129. Install the R.H. side sealing element #050367.  
Secure with the following hardware:  
**bolts #5001697 (5x)**  
**lock washers #502570 (5x)**

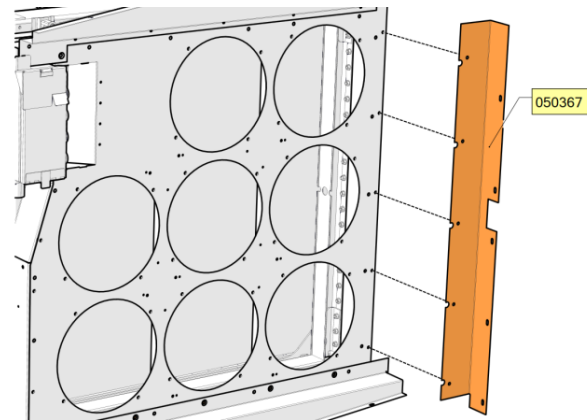


FIGURE 159

130. Install the **fans** and **fan hand guards** on the panel. Snap the fan blue connector in the holes punched on the panel for that matter.



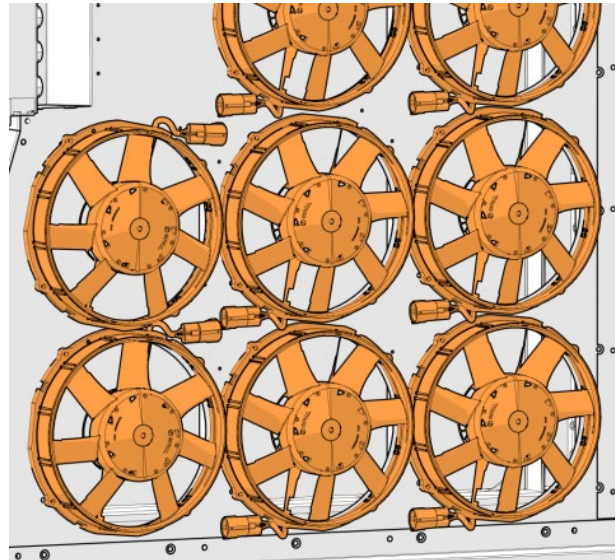
**FAN HAND GUARD**

Install with the following hardware:

**32x bolts #502686**

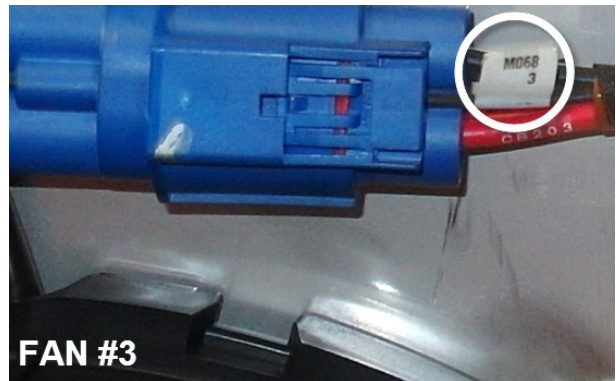
**32x lock washers #5001833**

**Prescribed torque:40 lbf-in**



**FIGURE 160**

131. Get the fan drive harnesses kit #068820. **Take note that each harness is specifically identified with a number corresponding to an appropriate fan location.**



**FIGURE 161**

132. Route and secure the fan harnesses as shown on the images.

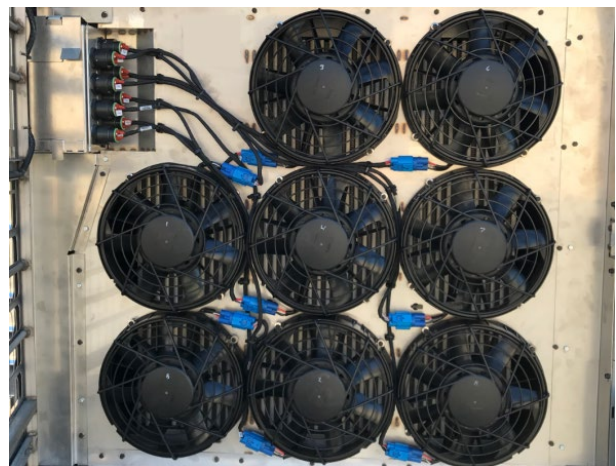
Secure with the following parts:

**A= nylon tie mount #504013 + rivet  
#504379 + nylon tie #504016**

**(11x)**

**B= nylon tie #504016 (4x)**

**Do not tighten the nylon ties at this moment**



**FIGURE 162**

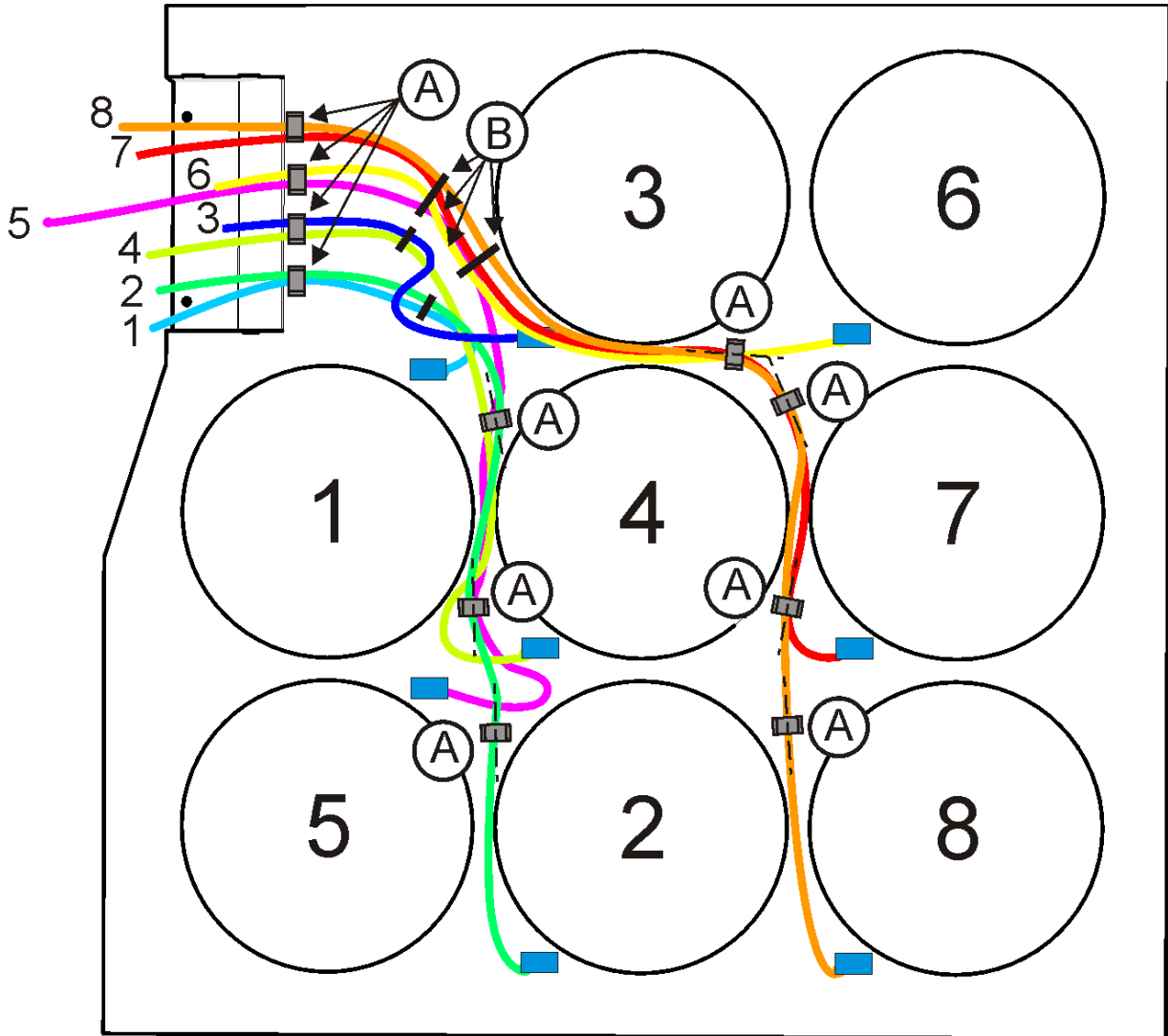


FIGURE 163

133. Connect each fan to the corresponding connection port on the circuit breaker box.

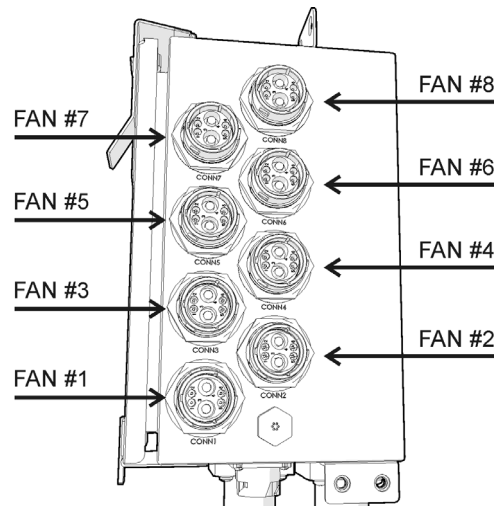


FIGURE 164

134. Using the blue hose previously saved, make a protective sheath. Cut to an appropriate size and secure around the cables using nylon ties.



FIGURE 165

135. Complete the connection to the fan circuit breaker box (three connectors: gray, black and red).

**A:** fan drive ground cable (black connector)

**B:** fan drive power cable (red connector)

**C:** "fan to RJB interface" harness (gray connector)

**Secure the cables appropriately using nylon ties and/or « handcuff » type nylon tie #N37749 as required**

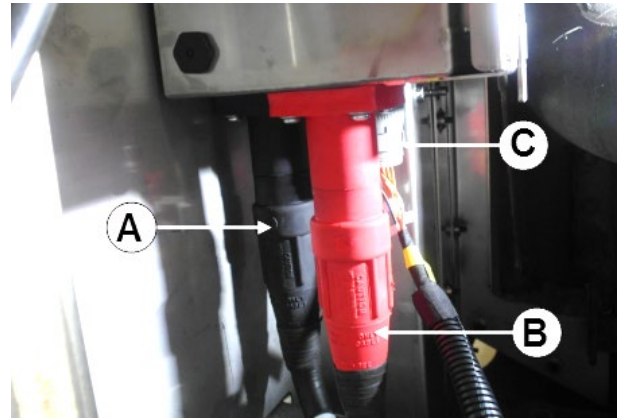


FIGURE 166

On the engine hot side, remove the radiator inlet pipe



FIGURE 167

136. Install the sealing element #050415.

Secure with the following hardware:

- **bolts #5001697 (1x)**
- **lock washers #502570 (1x)**

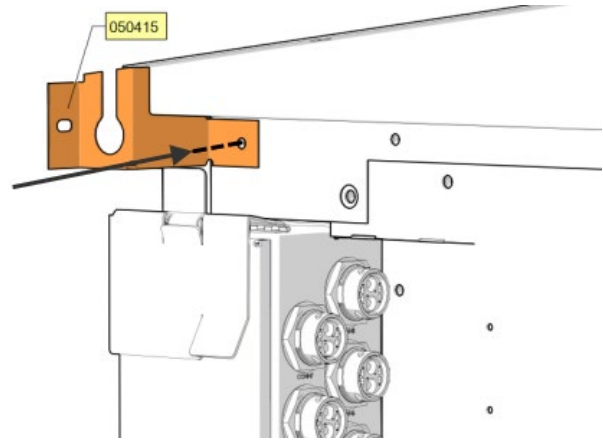


FIGURE 168

137. Install the sealing element #050364.

Secure with the following hardware:

- **screw #502848 (1x)**

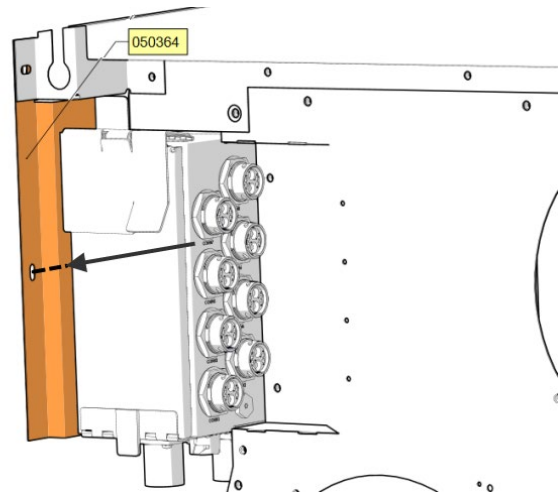


FIGURE 169

138. Install the sealing element #050363.

Secure with the following hardware:

- **bolts #5001697 (4x)**
- **lock washers #502570 (4x)**

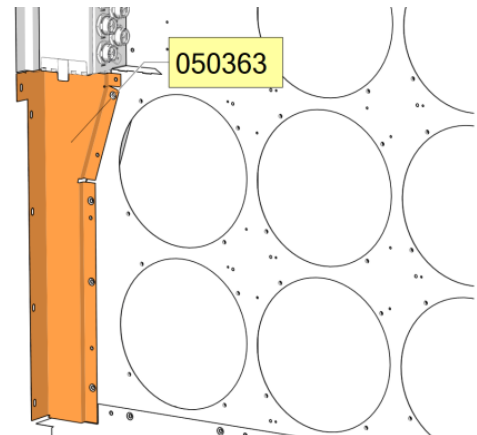


FIGURE 170

139. Complete the installation of the sealing elements. Screw the panels to the chassis threaded holes where shown on the image.

Use the following hardware:

- **screw #502848 (19x)**

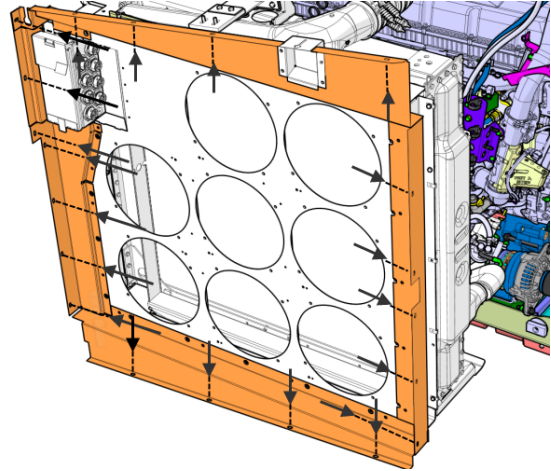


FIGURE 171

## INSTALLATION OF ELECTRIC COMPONENTS AND HARNESS CONNECTIONS IN THE MAIN POWER COMPARTMENT



- 
140. In the battery compartment, disconnect the battery ground cable from the chassis ground stud.

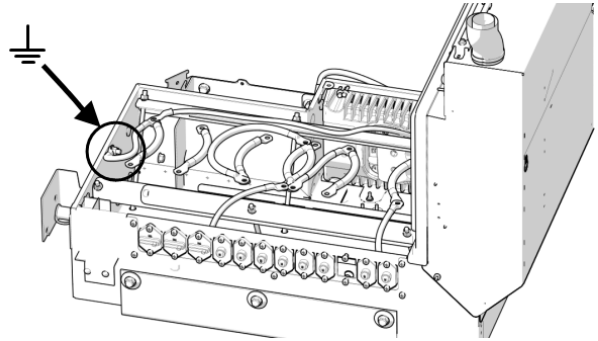


FIGURE 172

- 
141. Make sure there is no voltage applied to the master relay R1 posts and then, remove the master relay R1 cover if applicable.

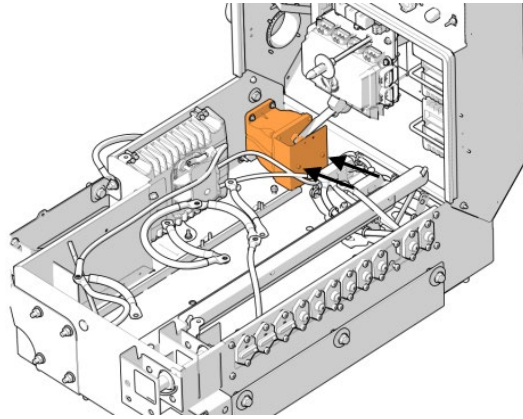


FIGURE 173

- 
142. Complete the routing of the “***fan drive power cable***” and the “***alternator power cable***” inside the electrical compartment through the upper cable boot.

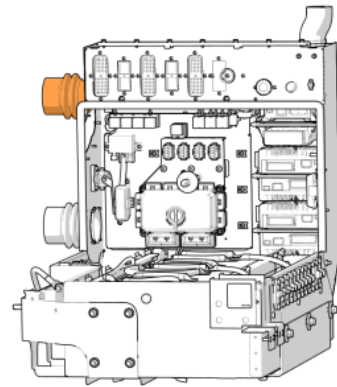


FIGURE 174

143. Install the **fuse holder #563750** at the location shown on the image. To do so, drill two 11/64 pilot holes for the installation of the fuse holder. Secure with the following hardware:

**A: tapping screw #500658 + flat washer #5001341**

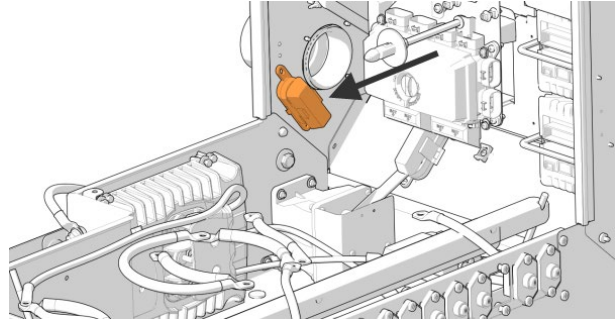


FIGURE 175

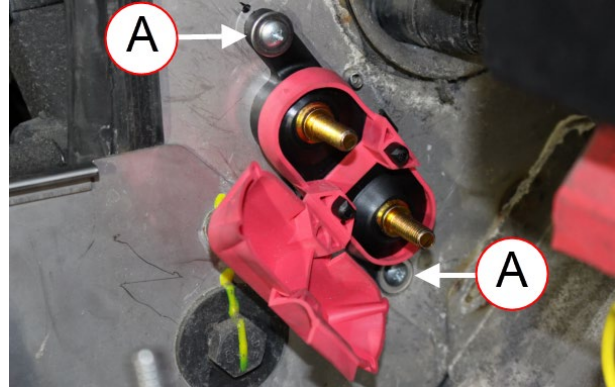


FIGURE 176

144. Prepare to the installation of the MCM module #23499009\_EFD.

First, use the MCM as a template to mark the drilling position. Drill three holes of  $\text{Ø}1/4"$ .

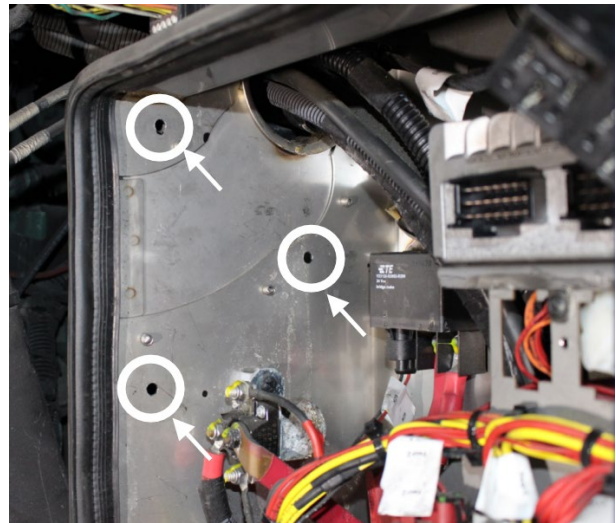


FIGURE 177

145. Prepare the mounting screws as shown on the image using the following hardware.

**A: Screw #502888 (3x)**

**B: Flat washer #502709 (9x)**

**C: Nut #502854 (3x)**

**Note: At each of the three mounting points, there is a flat washer on the other side of the bulkhead.**

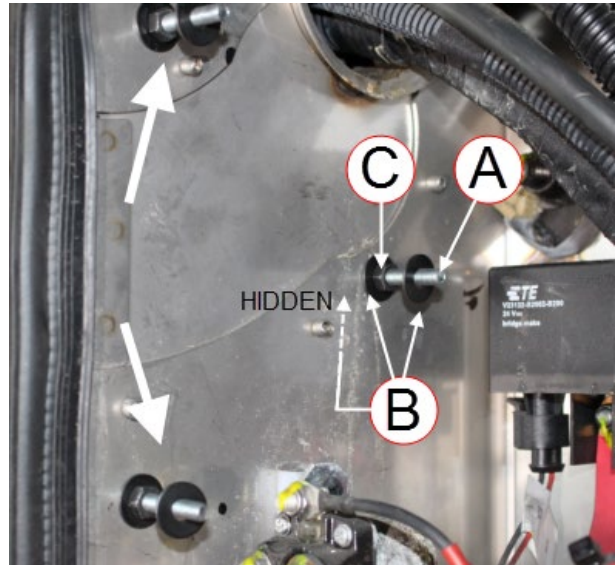


FIGURE 178

146. Install the MCM module 23499009\_EFD.

**D: Flanged nut #5001932 (3x)**

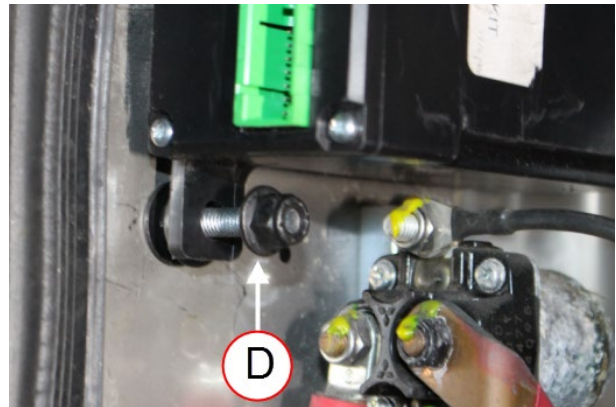


FIGURE 179

147. Cut one pieces of 4 inches (100 mm) long of **rubber extrusion #506025**.

148. Using good industrial glue (Loctite 404 or similar product), glue the piece of rubber extrusion on the I/O module support #053043 as shown on the image.

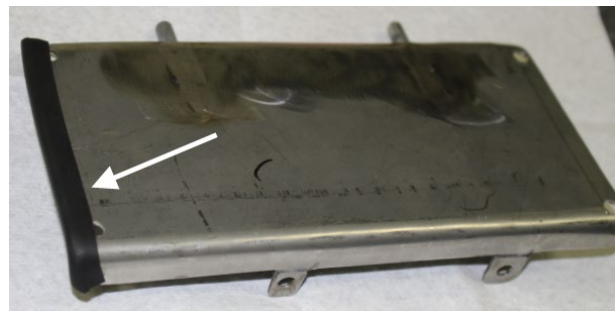


FIGURE 180

149. Use the I/O module support #053043 as a template to mark the drilling position. Drill four (4) holes as shown on the image.

Diameters:

2 holes for the rods:  $13/64$ "

2 holes for the screws:  $1/8$ "

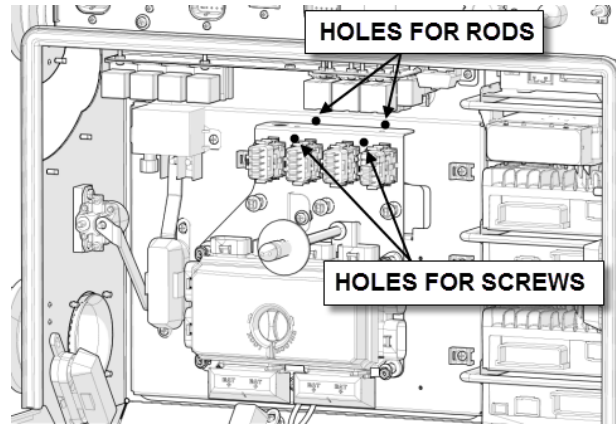


FIGURE 181

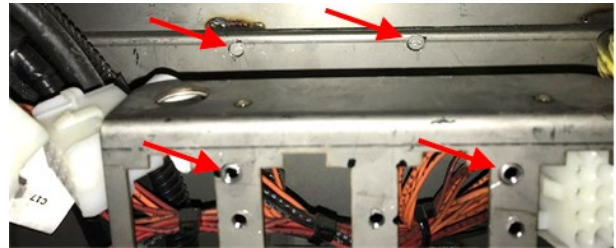


FIGURE 182

150. Install the **telltale light module bracket #050303** between the two groups of the relay. Fasten using **two (2) rivets #504379**.

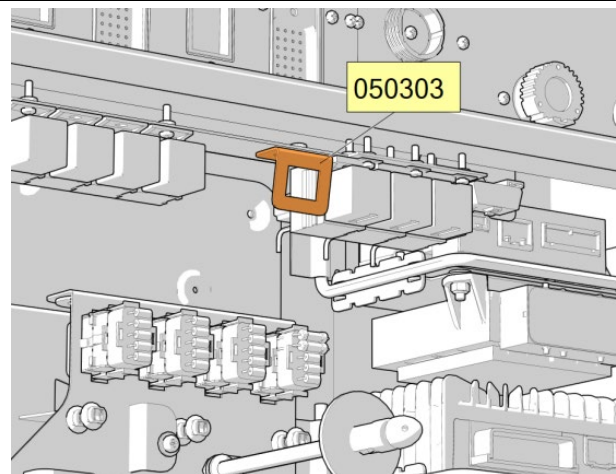


FIGURE 183

151. Fix the I/O module on the support #053043. Secure the module using the following hardware:

- **screw 10-24x 5/8 #5001447 (4x)**
- **nut with nylon insert #5001180 (4x)**

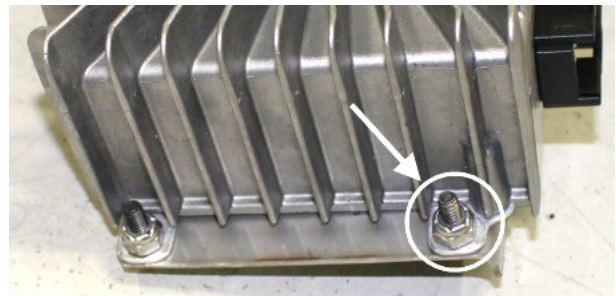


FIGURE 184

152. Install the I/O module. Secure with the following hardware:

**A: screw #500623 (2x)**

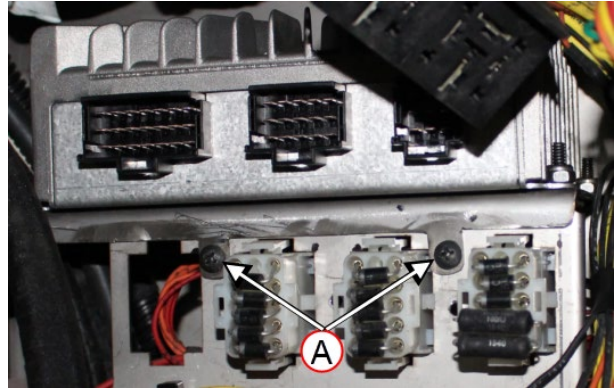


FIGURE 185

153. Place the **300A fuse #564520** (item A) in the fuse holder previously installed.

154. Connect to the lowest post of the fuse holder the two (2) following cables that are routed from the alternator and the fan drive circuit breakers box:

- **Alternator power cable (item B)**
- **Fan drive power cable (item C)**
  
- **item D: flat washer #5001341 (1x) & nut #5001983 (1x)**

155. Thread the nuts and tighten to a torque of 96 lbf-in (11 Nm)

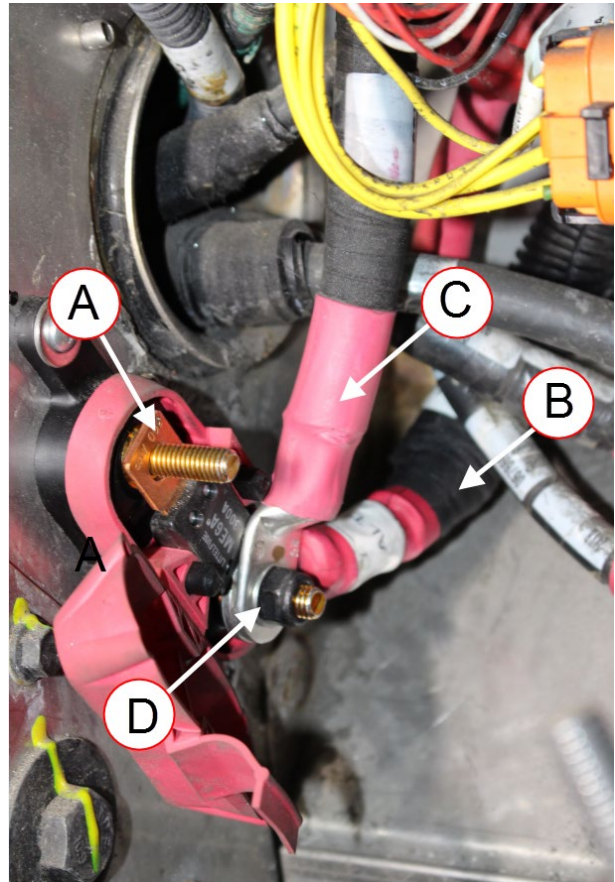


FIGURE 186

156. Connect the elbow lug of the "master relay R1 to 300A fuse" cable #23498450 to the R1 stud identified on the image and the upper stud on the fuse holder.

**item A: flat washer #5001341 (1x) & nut #5001983 (1x)**

**Master relay R1- Port 30 – M10-1.5 stud nut torque: 160-195 lb-in (18-22 Nm)**

**Fuse holder: tighten to a torque of 96 lbf-in (11 Nm)**

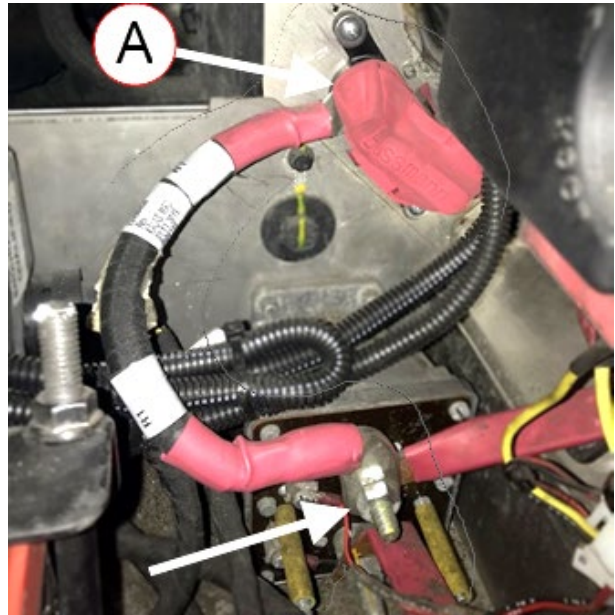


FIGURE 187

157. In the upper part of the electrical compartment, attach the cables and harnesses as shown. Use the following hardware

- **nylon tie #504016 (3x)**

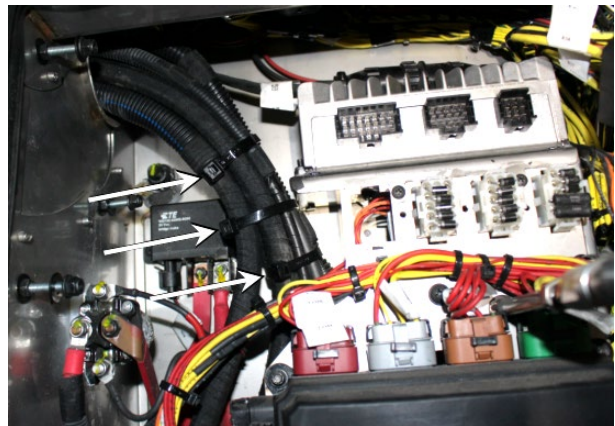


FIGURE 188

158. On harness #23490553, cut the three ring terminals and replace by three (3) terminals #561608.
159. In the main power compartment, locate connector **CCUST**.
160. Unplug the socket terminal connector of CCUST. Insert the three (3) terminals in the connector.

*circuit 24VI in cavity #1*  
*circuit 24 VD in cavity #3*  
*ground circuit in cavity #4*

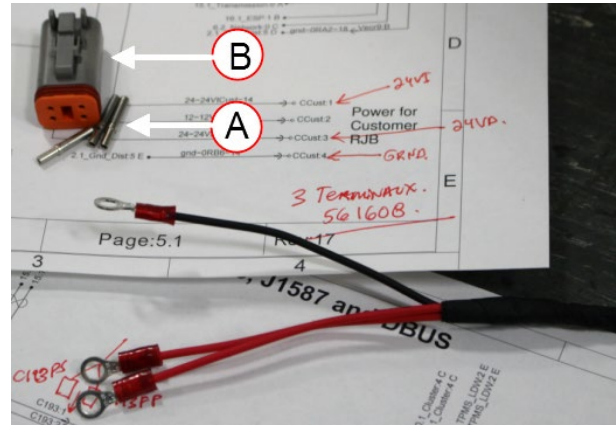


FIGURE 189

**A:** terminal #561608 (3x)

**B:** socket terminal connector of CCUST

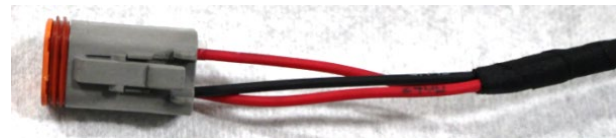


FIGURE 190

161. In the main power compartment, connect the "fan to RJB interface harness" to the "MCM to I/O-B interface harness" #23445869 by means of connector C-EFD1.
162. Connect the MCM and the I/O-B module together using the "MCM to I/O-B interface harness" #23445869.
163. Connect the OEL resistors connector **RES1F** and **RES2F** (part #563593) to the "MCM to I/O-B interface harness". See the image at right and the following pictures for reference.

*Use nylon ties as required, ideally one nylon tie every 6 inches.*

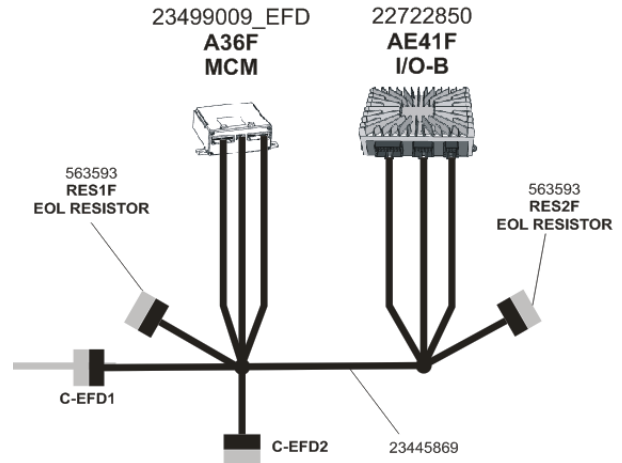


FIGURE 191

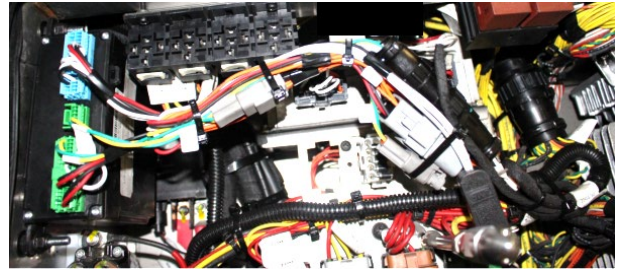


FIGURE 192

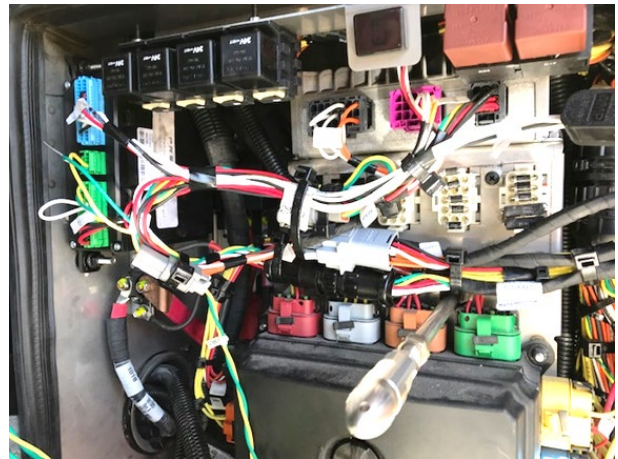


FIGURE 193

164. In the main power compartment, connect the “**vehicle interface harness**” #23490553 to the “MCM to I/O-B interface harness” by means of connector C-EFD2.

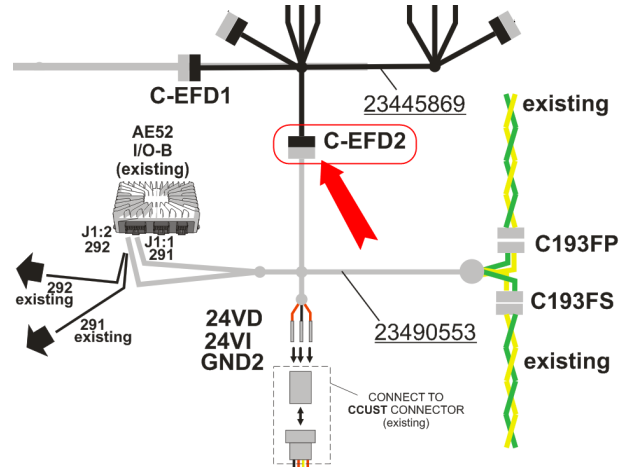


FIGURE 194

165. Plug the socket terminal connector previously installed to the CCUST existing in the main power compartment.

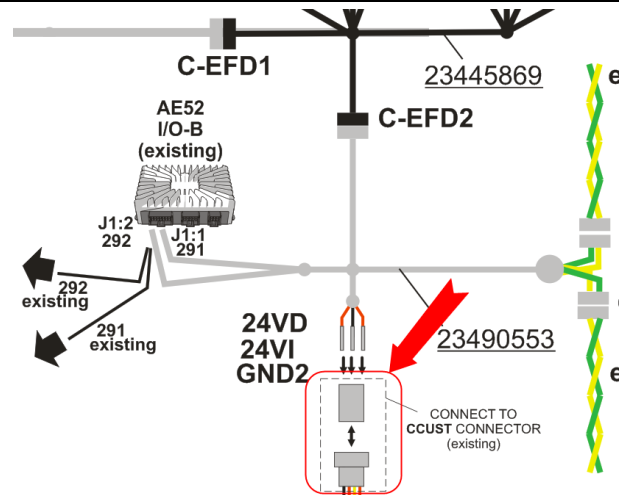


FIGURE 195

166. Get the J1939 signal. To do so, locate connector C193 among the existing harnesses of the main power compartment.  
167. Disconnect connector C193 and connect with C193FS and C193FP of the “**vehicle interface harness**” #23490553.

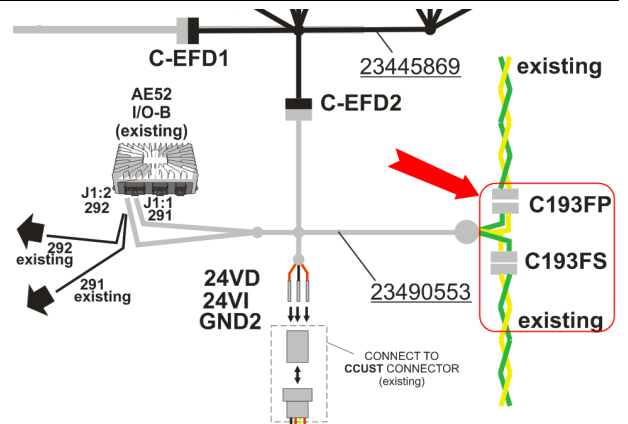


FIGURE 196

168. In the main power compartment, locate I/O-B module A52 (alternately named AE52).
169. At **A52** (or AE52), remove existing circuit 291 and 292 from connector J1:1 (pin 1) and J1:2 (pin 2).
170. For each circuit, cut the terminal and put a heat shrinking sleeve at the end of the wire. Those circuits won't be used anymore.
171. Insert circuit 291 and 292 of the "**vehicle interface harness**" #23490553 into connector J1 pin 1 and J1 pin 2 respectively.

**Use nylon ties as required to secure harness #23490553**

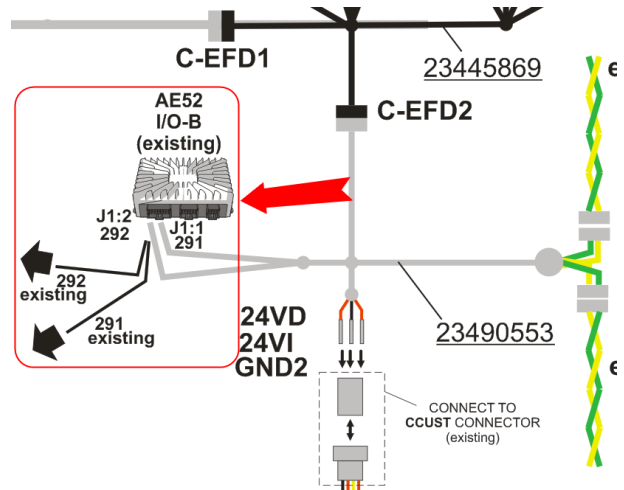


FIGURE 197

172. Place the alternator telltale insert #391028 in the telltale light module #562113.
173. Install the telltale light module in the telltale module bracket.
174. Connect the branch of FAN TO RJB INTERFACE HARNESS identified ALT-L to the telltale light module.

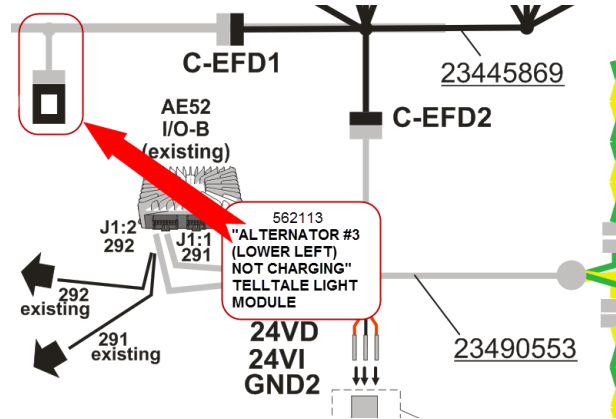


FIGURE 198

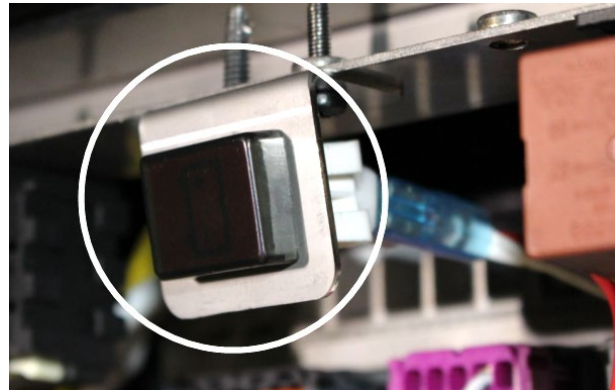


FIGURE 199

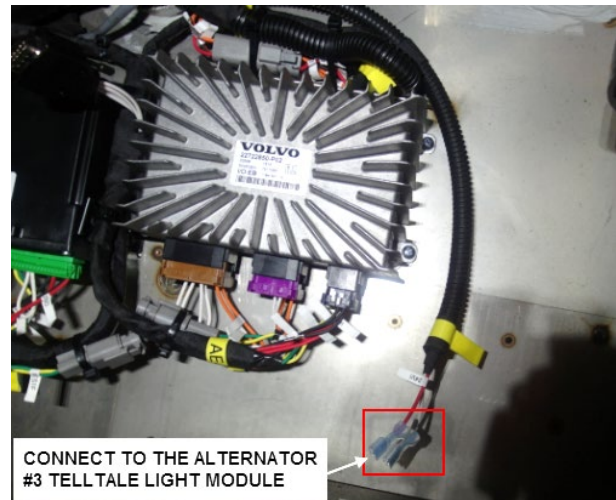


FIGURE 200

175. There are remaining nylon ties and tie mounts in the kit. Use them to secure the harnesses and cables that may seem loose. The goal is to prevent rubbing of the cables and harnesses.
176. Tighten all the nylon ties that were left loose, for example, the one between the fan circuit breakers box and the main power compartment.

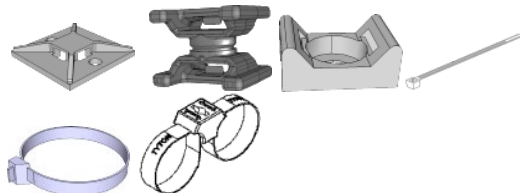


FIGURE 201

177. Place one (1) warning decal #069205 as shown on the image.

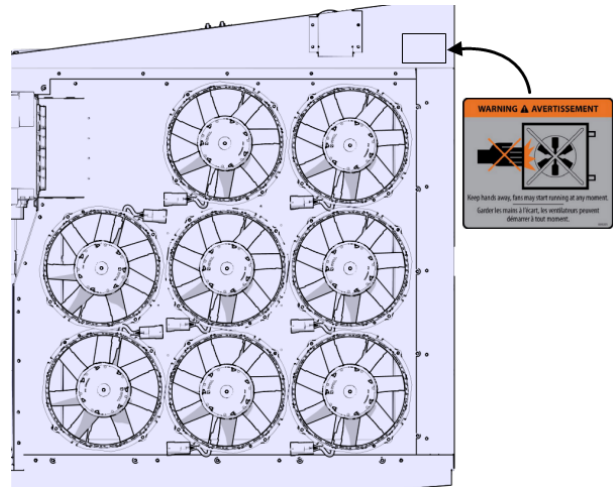


FIGURE 202

178. Install a second warning decal #069205 as shown on the radiator door.

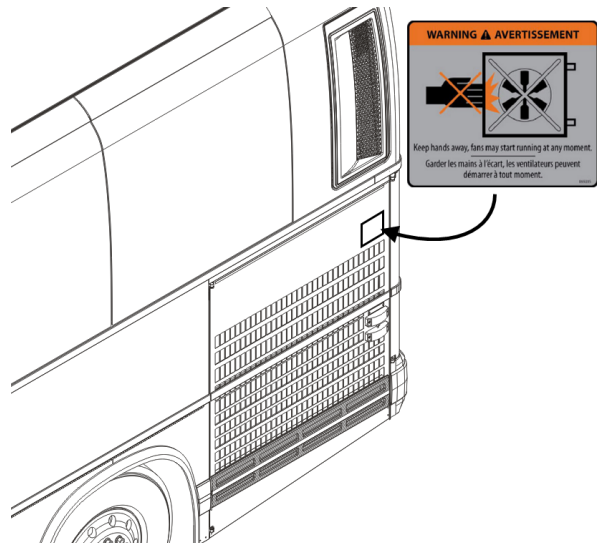


FIGURE 203

179. Fasten the radiator door **upper arm assembly**.

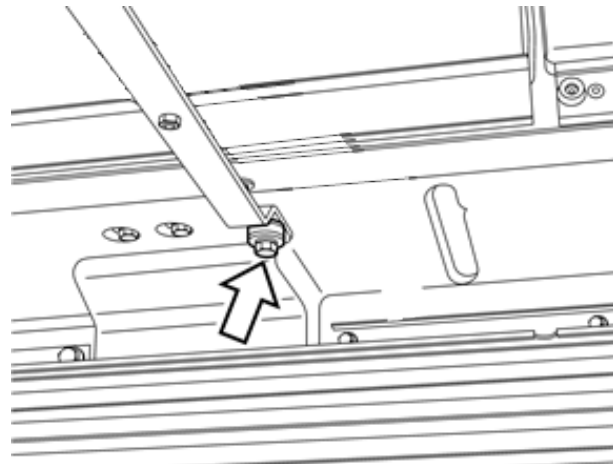


FIGURE 204

180. Refill the cooling system. Connect coolant extractor. Use coolant extractor to refill the coolant from the engine.

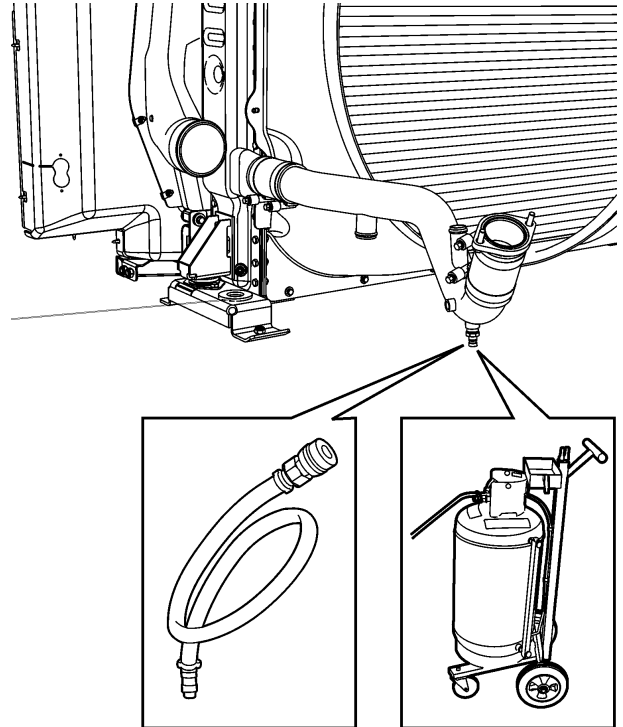


FIGURE 205

181. Reinstall the bumper.

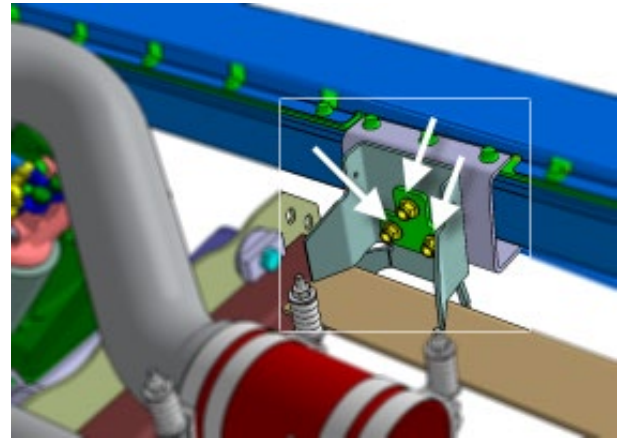


FIGURE 206

182. Reinstall the **access panel** located behind tag axle L.H. side wheel.

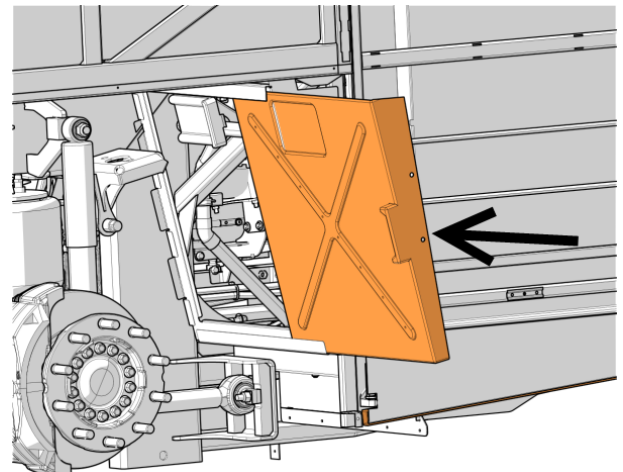


FIGURE 207

183. In the battery compartment, connect the battery ground cable to the chassis ground stud.

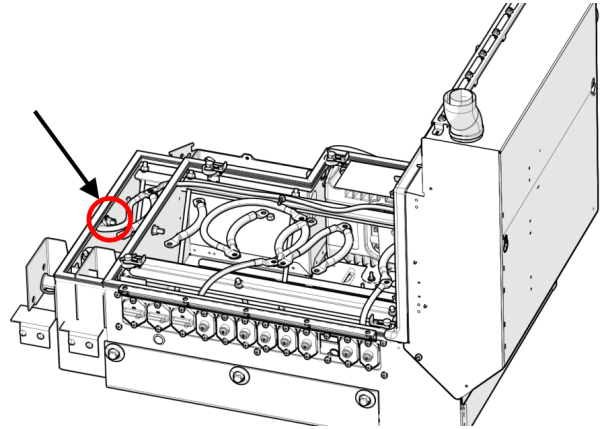


FIGURE 208

184. Set the battery master switch to the ON position.  
185. Set the ignition switch to the ON position.  
186. In the main power compartment, reset the circuit breakers and wait two (2) minutes for the new installer I/O-B module to be programed.

### **IMPORTANT NOTE**

#### ***VEHICLES EQUIPPED WITH OPTIONAL PRIME ENERGY MANAGEMENT SYSTEM***

*TO PREVENT OVERLOADING THE L.H. SIDE ALTERNATOR, IT IS VERY IMPORTANT TO DISABLE « PRIME » SYSTEM ON VEHICLES RECEIVING THIS CONVERSION. PLEASE CONTACT YOUR NEAREST PREVOST SERVICE CENTER TO HAVE THE PRIME SYSTEM DISABLED.*

### **SYSTEM TEST**

187. Start the engine to idle.  
188. With the engine in idle (600 rpm), use the Diagnostics menu of the Driver Information Display to engage the fans in speed 1.

#### **Diagnostics > Vehicle Tests > Activate Radiator FAN Speed 1**

The height (8) fans should run at 50% of the maximum speed. You need to evaluate the sound level and the power of the air stream to determine the speed.

189. Engage the fans in speed 2.

#### **Diagnostics > Vehicle Tests > Activate Radiator FAN Speed 2**

The eight (8) fans should run at 75% of the maximum speed.

190. Set the engine to the fast idle, the fans should then engage at 100% of the maximum speed.  
191. If the fans behave in accordance with the criteria of the previous steps, then they operate normally.

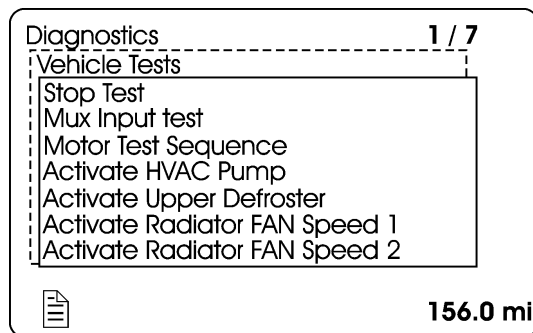


FIGURE 209

## **PARTS / WASTE DISPOSAL**

Discard waste according to applicable environmental regulations (Municipal/State[Prov.]/  
Federal)