



Countries:	CANADA, UNITED STATES	Document ID:	IK1700018
Availability:	ISIS, FleetISIS, Body Builder, IsSIR	Revision:	3
Major System:	WHEELS	Created:	7/18/2019
Current Language:	English	Last Modified:	1/13/2020
Other Languages:	NONE	Author:	Charles Schroeder
Viewed:	714		

[Less Info](#)

Hide Details

Coding Information

Copy Link 	Copy Relative Link 	Bookmark View My Bookmarks	Add to Favorites 	Print 	Provide Feedback 	Helpful 5	Not Helpful 0
----------------------	-------------------------------	--	-----------------------------	------------------	-----------------------------	-------------------------	-----------------------------

Title: CV Vibration - wheels

Applies To: CV

CHANGE LOG

Please refer to the change log text box below for recent changes to this article:

<ul style="list-style-type: none"> 01/13/2020 - Updated service parts information for steer tire 10/02/2019 - Updated service parts information to Contiential tires 08/20/2019 - Author updated for feedback purposes 08/12/2019 - Initial Article Release

DESCRIPTION

This article applies to CV vehicles that experience an objectionable wheel end vibration felt in the cab at highway speeds.

Possible Causes:

- Abnormal tire wear
- Excessive tire pressure
- Excess tire runout
- Excess wheel runout
- Excess wheel hub runout
- Worn or damaged wheel hub bearing
- Improper wheel hub bearing preload
- Differential carrier bearing problem
- Differential ring gear problem
- Damaged axle shafts

SYMPTOM(s)

Customer Observations or Concerns:

Wheel end vibration frequencies do not follow engine rpm, but rather vehicle speed. Driveline vibrations also follow vehicle speed and should not be confused with a wheel end vibration.

Wheel end vibrations will be lower frequency than driveline vibrations. The driveline rotates at higher speed than the wheels: Wheel speed x differential gear ratio = driveline speed. Wheel end vibrations will cause lower frequency (shake or hop), and driveline vibrations will create higher frequency (buzz or whine).

Wheel end vibrations will not change when engine torque is varied.

Wheel end vibrations often occur within a specific vehicle speed range. When tire / wheel frequency aligns with the suspensions natural frequency, resonance occurs increasing the driver's perception of excessive vibrations. Due to the suspensions natural frequency a wheel end vibration can disappear when vehicle speed is increased or decreased beyond a specific resonance speed range.

Some wheel end vibrations will phase in and out at the same vehicle speed. This is caused by multiple wheel end vibrations. When in phase the vibration from one wheel will come in phase with the vibration from another wheel and cancel out the vibration. When not in phase the vibration from one wheel will combine with another wheel creating a high amplitude vibration.

SPECIAL TOOL(s) / SOFTWARE

Use the Vibsense app or NVH app to measure the frequency of the vibration to determine if it is wheel end frequency. Please follow [IK0600020](#).

SERVICE PARTS INFORMATION

Primary path: Correct issue using the original tires and contact your local tire representative for assistance in repairing/replacing any tires deemed to be faulty.

Optional path: Replace with tires shown below if the issue with the original tire supplier cannot be corrected.

Kit Description	Part Number	Quantity Required	Notes
225/70R19.5 LR-G HYBRID HS3 CONTINENTAL	N/A	2	Steer tires. Order only if the issue with the original tire supplier cannot be corrected
225/70R19.5 LR-G HDR CONTINENTAL	N/A	4	Drive tires. Order only if the issue with the original tire supplier cannot be corrected

DIAGNOSTIC and REPAIR STEP(s)

Step	Action	Decision
1	<p>DIAGNOSTIC:</p> <p>Determine the vehicle has an objectionable wheel end vibration per IK0600020</p>	<p>Yes: Proceed to Step 2.</p> <hr/> <p>No: If the vehicle has a higher frequency vibration/noise equating to an engine/driveline system, please create a Tech Services case file for assistance.</p>

Step	Action	Decision
2	<p>DIAGNOSTIC & REPAIR:</p> <p>Determine if tire and wheel assemblies have damage, excessive mud, snow pack, or debris affecting wheel balance, improper tire wear, improper tire seating, or runout with a visual inspection.</p>	<p>Yes: Clean up, repair or replace worn, damaged, or out of specification components. Adjust tire pressure to 90 PSI. After repairs are complete, retest for symptom.</p> <p>No: Proceed to step 3</p>

Step	Action	Decision
3	<p>DIAGNOSTIC & REPAIR:</p> <p>Has the vibration existed since the truck was new?</p>	<p>Yes: Proceed with Step 4</p> <p>No: Check prior repair history that could affect wheel end and inspect for service issues - Retest for symptom. If no issues found and unit still has the same vibration, proceed with Step 4.</p>

Step	Action	Decision
4	<p>DIAGNOSTIC & REPAIR:</p> <p>Use Hunter Engineering locator tool http://www.hunter.com/heavy-duty/forcematch-hd/search to see if a ForceMatch HD wheel balancer is in your immediate area.</p> <p>PRINT Tire Shop Worksheet. Mark the peak point of runout on each tire so it can be properly oriented when installed on the truck</p> <p>If a Hunter balancer is not in the immediate area, at a commercial tire shop, have all wheels rebalanced and check radial runout with a dial indicator on the balance machine. Dismount tire as needed and rotate on the rim to reduce runout as needed.</p> <p>Match Mounting Instructions</p> <p>Mark the peak point of runout on each tire so it can be properly oriented when installed on the truck.</p> <p>Retest for symptom. Does the unit still exhibit the same vibration?</p>	<p>Yes: Go to Step 5</p> <p>No: Release unit.</p>

Step	Action	Decision

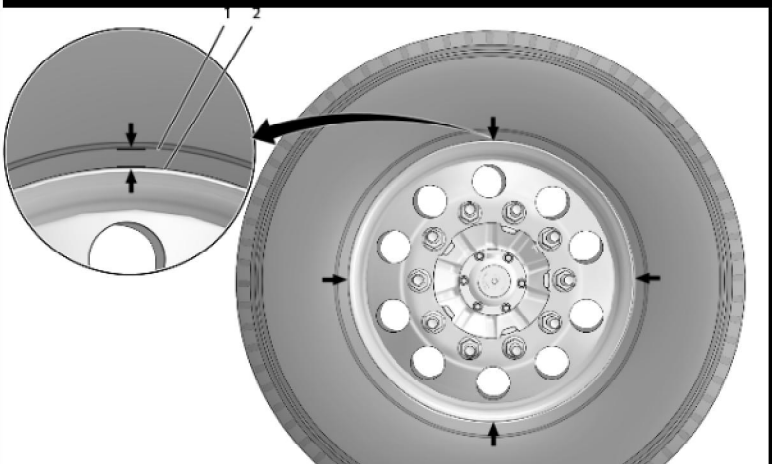
5	<p>DIAGNOSTIC & REPAIR:</p> <p>Determine if tire is properly seated to wheel</p> <p>Measure distance between tire guide rib and wheel edge in 4 locations 90 degrees apart.</p> <ul style="list-style-type: none"> • On steer tires, measure both the front and back of the tire. • On dual tires, do not measure guide ribs located between dual wheels. <p>Are measurements on each side within 1/16" (1.59 mm) of each other?</p> 	<p>Yes: Go to step 6</p> <p>No: Inspect tire and replace if damaged. If tire is not damaged, have a trained / qualified tire technician dismount tire, lube bead and remount tire to wheel. After repairs are complete, remeasure runout and retest for symptom</p>
---	--	---

Step	Action	Decision
6	<p>DIAGNOSTIC & REPAIR:</p> <p>Determine if wheel is properly mounted to hub.</p> <ol style="list-style-type: none"> 1. Determine if wheel is flush against hub mating surface. 2. Inspect hub pilot pads for damage such as bending or gouging. 3. Check lug nuts torque. See appropriate Operation and Maintenance Manual for lug nut torque information. <p>Are the wheels properly mounted?</p>	<p>Yes: Go to step 7</p> <p>No: Remove wheel from hub. Remove corrosion / debris from between hub and wheel. Properly mount wheel to hub. After repairs are complete, retest for symptom.</p>

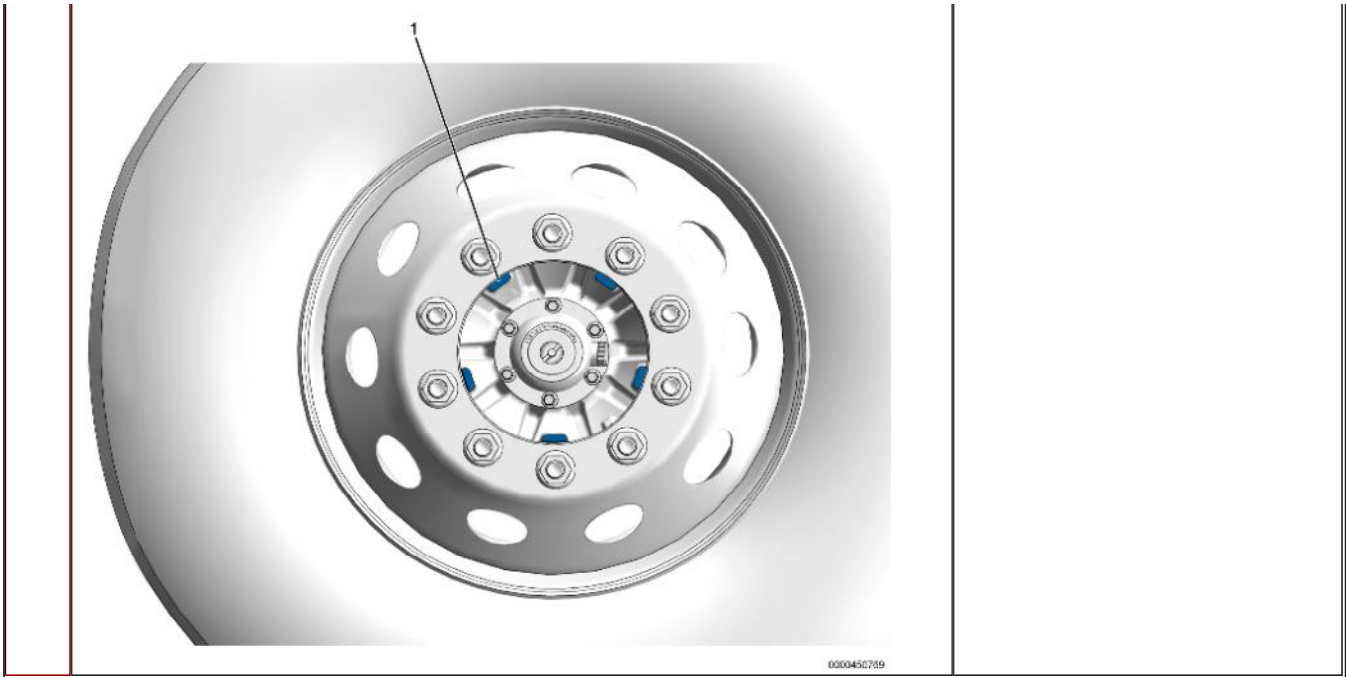

Step	Action	Decision
7	<p>DIAGNOSTIC & REPAIR:</p> <p>Determine if tire tread depth has excessive variation. Measure tire tread depth in 4 locations 90 degrees apart. Measure at center of tread. Is tread depth variation 3/32 inch or more?</p>	<p>Yes: Replace affected tires. After repairs are complete, retest for symptom.</p> <hr/> <p>No: Go to Step 8.</p>

Step	Action	Decision
8	<p>DIAGNOSTIC & REPAIR:</p> <p>Determine if hub pilot pad to wheel clearance is contributing to a radial runout.</p> <ol style="list-style-type: none"> 1. Using a feeler gauge, measure clearance between hub pilot pads and wheel. 2. Determine location of greatest hub wheel clearance. <p>Is greatest point of hub wheel clearance approximately in line with the measured tire / wheel assembly high spot?</p>	<p>Yes: Rotate tire / wheel assembly high spot to the top (12 o'clock) position. Loosen wheel lug nuts and allow gravity to shift wheel onto hub pilot pads. Tighten wheel lug nuts. Measure tire / wheel assembly runout to be within 0.040 in (1.016 mm). Retest for symptom</p> <hr/> <p>No: Go to Step 9.</p>

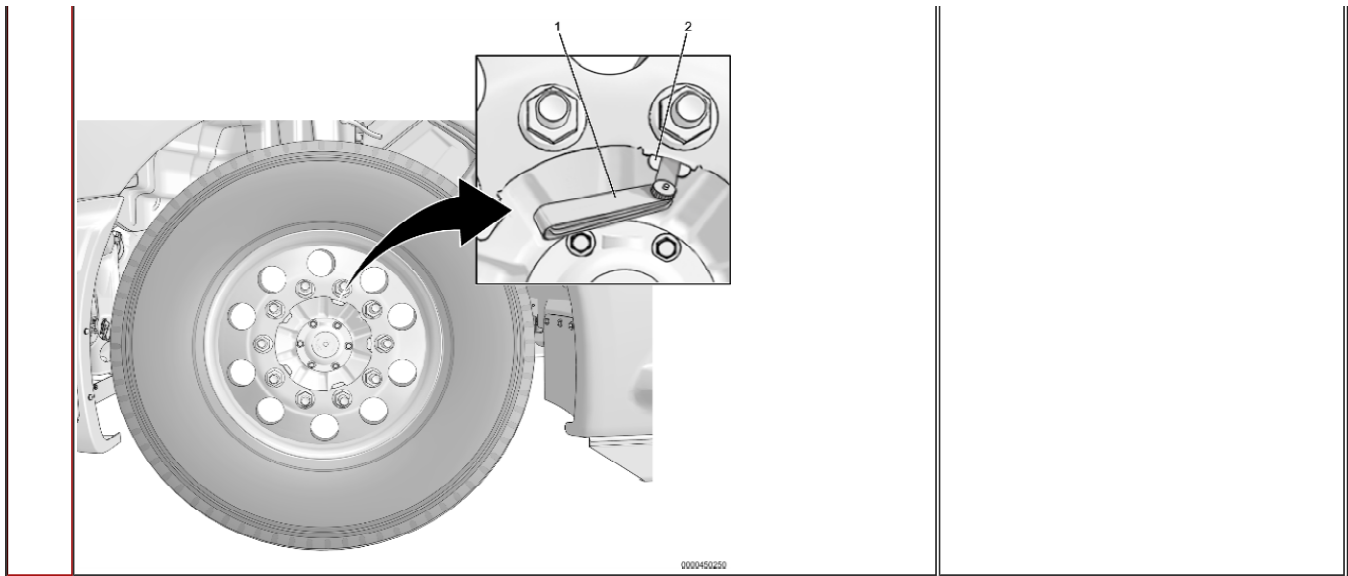

Step	Action	Decision
9	<p>DIAGNOSTIC & REPAIR:</p> <p>Determine if tire / wheel assembly runout can be reduced by match mounting. When installing rear dual wheels: Install high spot of each tire / wheel assembly 180 degrees from each other Does the unit still exhibit the same vibration?</p>  <p style="text-align: center; font-size: small;">0000448593</p>	<p>Yes: Due to the size of the CV tires, a tire shop with a Hunter Road Force® Elite GSP9700 machine may not have the appropriate adapters to radial force balance these tires. Please contact the tire manufacturer for support or create a tech services case file for further support. Consider installing the tires in the service parts information of this article.</p> <p>No: Release the unit.</p>

WARRANTY INFORMATION

Tires are not eligible for warranty reimbursement. If the issue with the original tire supplier cannot be corrected, contact your Navistar CSE for possible goodwill assistance.

Standard Repair Time(s):

Refer to the [SRT Manual](#) for Repair Times

OTHER RESOURCES

[Master Service Information Site](#)



 Hide Details

Feedback Information

Viewed: 713

Helpful: 5

Not Helpful: 0

No Feedback Found