



## INSTRUCTION TO SERVICE

**ITS: 58838**

<b>SECTION:</b>	400 Structure
<b>WRITTEN BY:</b>	Jeff Kosheluk
<b>SUBJECT:</b>	Weld repair cracks as required at def tank bracket. Add reinforcement bracket at def. tank bracket area.

# ITS 58838

**THIS ITS DOCUMENT SHOULD BE RETAINED AND REFERED TO FOR FUTURE MAINTENANCE UNTIL THE NEW FLYER PARTS AND/OR SERVICE MANUAL IS UPDATED TO REFLECT WORK DONE AS A RESULT OF THIS DOCUMENT. ENSURE THAT THIS DOCUMENT IS AVAILABLE FOR PARTS AND MAINTENANCE STAFF GOING FORWARD.**

THIS DOCUMENT AND THE CONTENTS DISCUSSED HEREIN ARE THE CONFIDENTIAL AND PROPRIETARY INFORMATION OF NEW FLYER INDUSTRIES CANADA ULC AND NEW FLYER OF AMERICA INC. AND ARE DISCLOSED BY NEW FLYER IN CONFIDENCE. THIS DOCUMENT AND THE CONTENTS HEREIN ARE NOT TO BE DISCLOSED BY THE INTENDED RECIPIENT WITHOUT THE PRIOR WRITTEN AUTHORIZATION OF NEW FLYER. ANY UNAUTHOIZED DISCLOSURE, REPRODUCTION OR OTHER DISTRIBUTION OF THIS DOCUMENT OR INFORMATION IS STRICTLY PROHIBITED AND MAY RESULT IN ACTION BEING TAKEN AGAINST THE PARTY MAKING THE UNAUTHORIZED DISCLOSURE. THIS DOCUMENT AND ALL COPIES HEREOF MUST BE RETURNED TO NEW FLYER UPON REQUEST.



**NEW FLYER**

**PROCEDURE:**

1. Turn the main battery disconnect switch to the “OFF” position.

**Note: Follow instructions in the service manual for PPE equipment and safety procedures when working on the bus. Safety harnesses must be worn when working on top of the roof.**

2. Remove any components and disconnect any electrical that will be in the way.

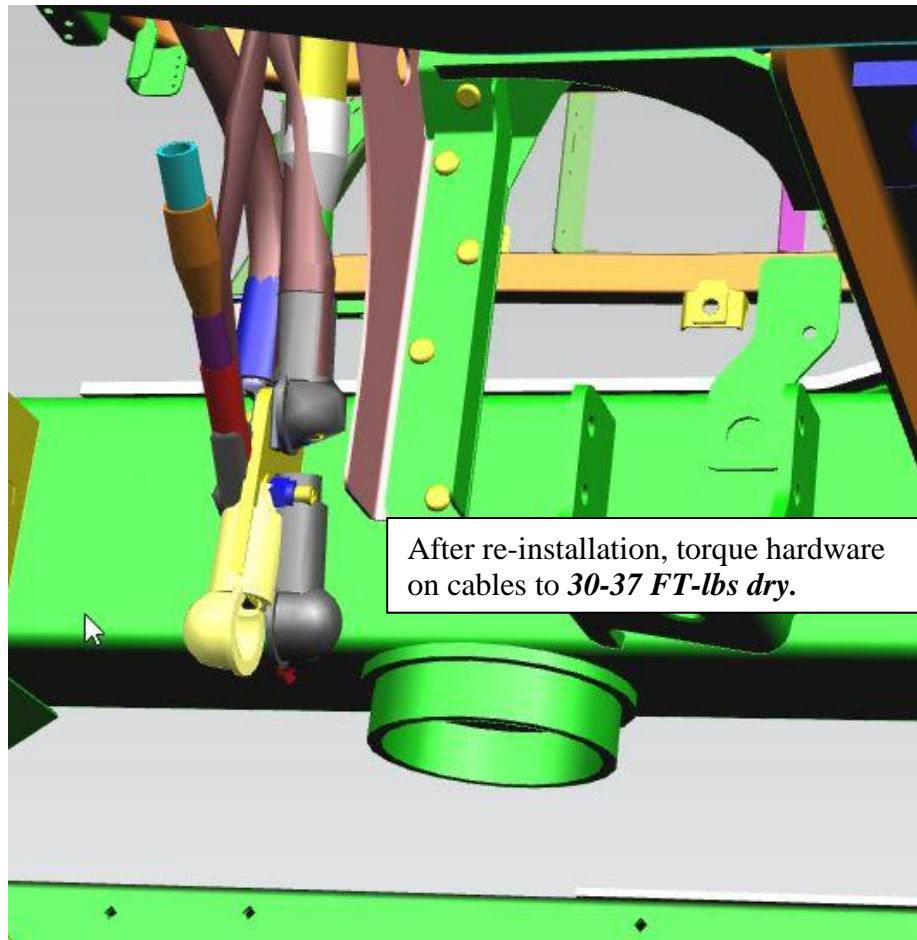

3. If there are no weld cracks, proceed to Part B.

**Note: For the weld crack procedure below, this will only be completed on buses that have a crack that requires to be re-welded.**

**PART A: WELD PREPARATION OF ALL AREAS THAT REQUIRE WELDING FOR CRACK REPAIRS (AS REQUIRED).**

👉 **NOTE:** The following instructions cover all these processes; use discretion as to which processes are required. Following the welding sheets as per Appendix A-C.

⚠️ **WARNING:** Ensure the following components are disconnected before welding:

- Battery cable
- Engine ECM – disconnect vehicle interface harness connector
- Transmission ECU – disconnect vehicle interface harness connector
- Vansco Multiplexing Modules (VMM) – disconnect all modules
- Destination sign – disconnect vehicle interface harness connector
- HVAC controller (if equipped) – disconnect vehicle interface harness connector
- Auxiliary heater (if equipped) – disconnect vehicle interface harness connector
- 3 connection points on the DPIM on the roof – P1120, P1121 & P1122
- Disconnect components for the BAE equipment

⚠️ **WARNING:** The following safety equipment must be available at the work station:

- Safety shields must be set up around the weld area to protect against flash hazards
- Fire extinguishers must be kept at each work station. Each operator should know the location of the extinguisher and how to operate it

**Note:** Use welding blankets around the area that will be welded to prevent damage to any components. Including all electrical and airlines.

4. Using a wire wheel or a similar tool, remove all zinc primer and Sika sealant from the areas to be welded. Clear a minimum of 2” around the areas to be welded. Be thorough; weld contamination must be minimized.
  - a. All welding must comply with Canadian Standards Association (CSA).



## NEW FLYER

5. Locally clean repair area's with vacuum to remove dust and debris. Wipe the weld areas clean with a clean lint free cloth.
6. **Repair cracked tube/bracket as per Appendix B to drill stop, groove and weld. Weld as per Appendix A & C. Note: This is only if crack is seen.**

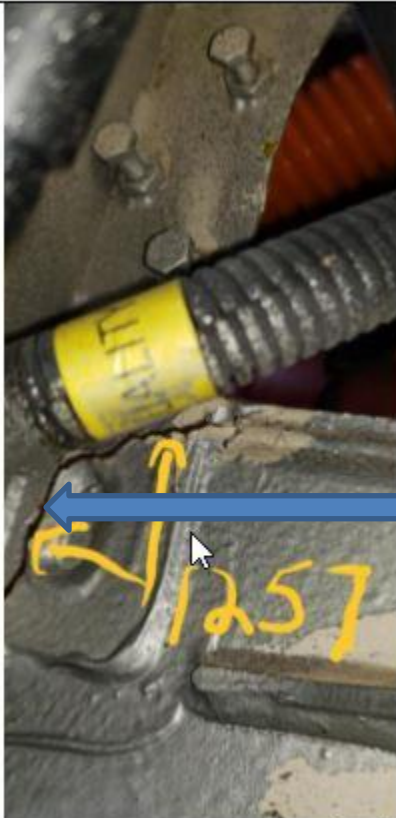

Shown typical crack that requires a weld repair.

SR2011 – Vehicle #1257 (10/23/2019)

7. Clean all welds to allow for application of zinc primer. Visually inspect for weld defects such as undercut, porosity, etc.; repair as required. Remove any sharp edges or significant spatter.  
**NOTE:** Visual inspection of all tubes in the area must be performed once welding is complete. This is to ensure that all cracks have been repaired, the tubes and gussets have been correctly installed, and no further cracking has occurred.
8. Once all welding is completed, clean surface of the tubes with mineral spirits. Let it flash off for 5 minutes. Scuff the surface area of the new metal or the area that has been welded with a scotch pad for proper adhesion. Follow instructions on **Appendix D** to apply zinc primer. Apply 2 to 3 light coats.



## NEW FLYER

9. Remove welding blanket (fire blanket) from work area. Inspect all electrical/airlines and components to ensure that there is no damage.

### **PART B: ADD ON RE-INFORCEMENT BRACKET TO DEF TANK MTG**

10. Clean the area to remove debris and undercoating from the surface area to install the new support bracket (**PN: 827849**) to ensure a good riveted joint.
11. Position the bracket in place and mark out the hole locations. Refer to Figure 1.

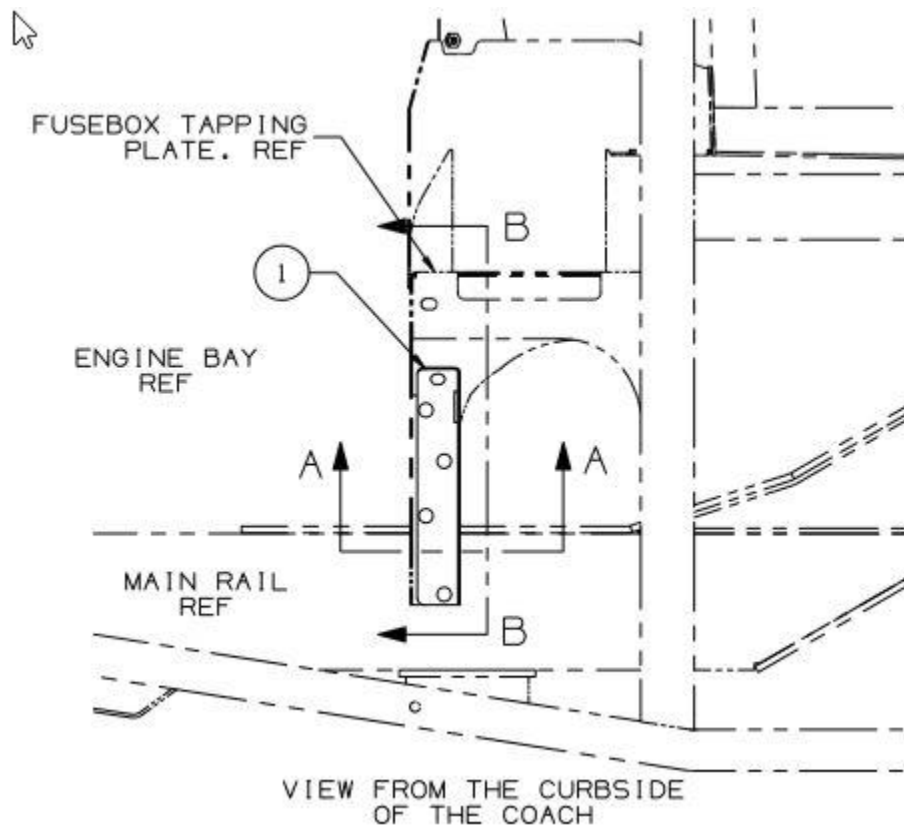

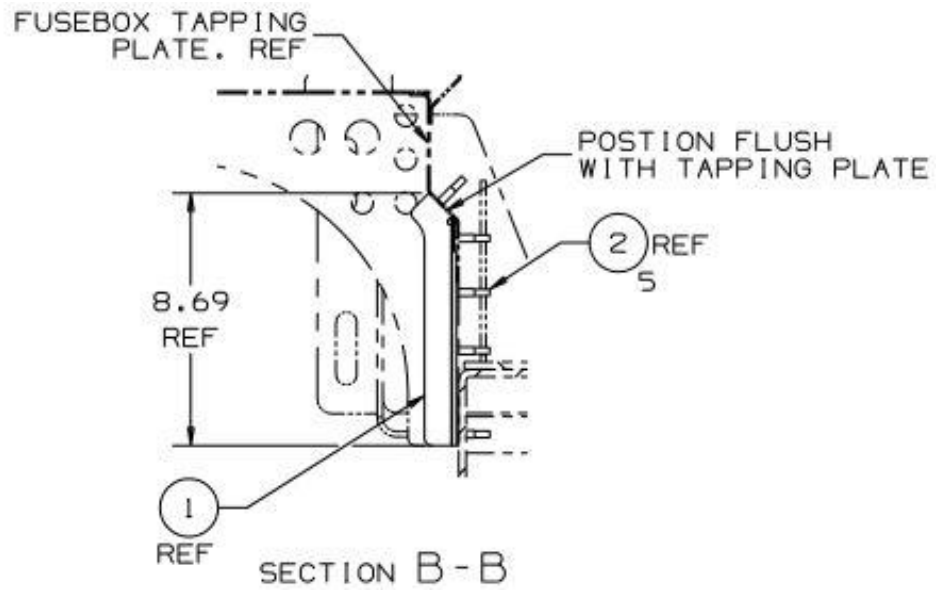
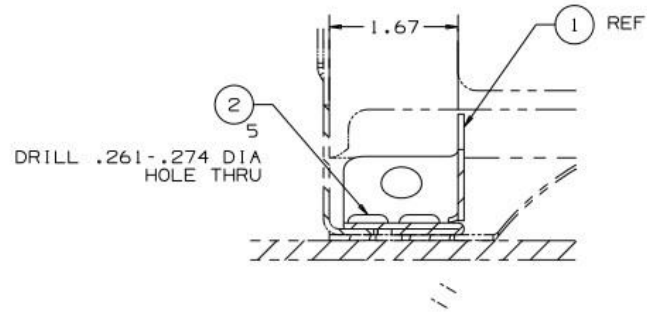

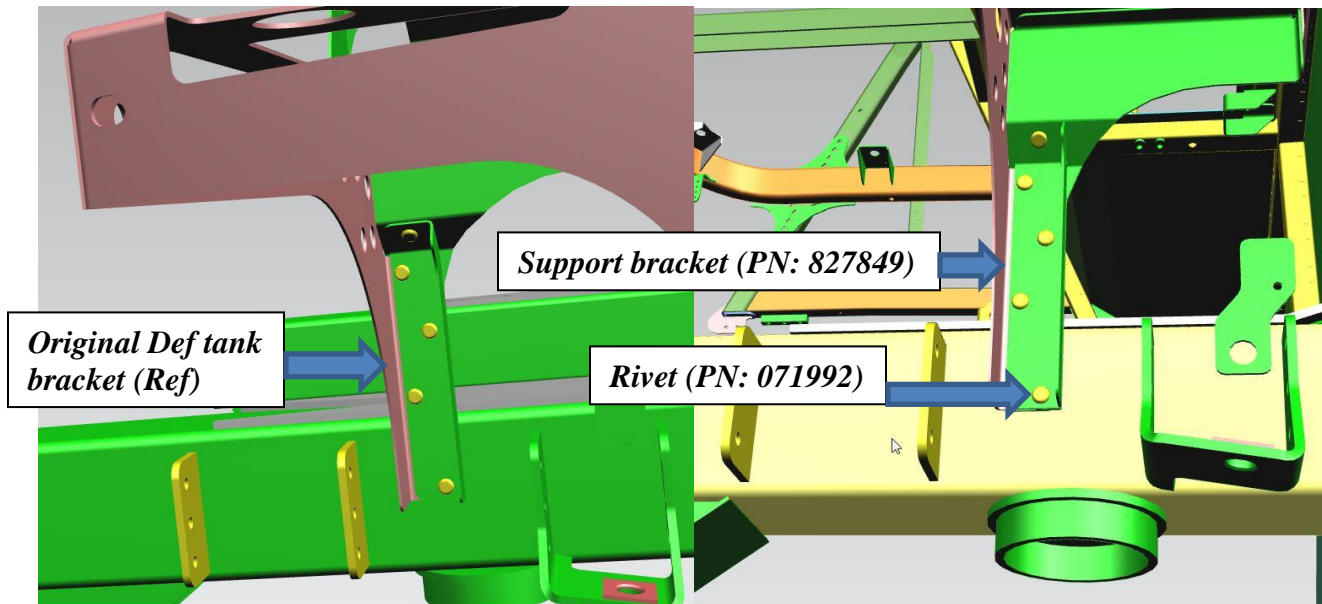

**FIGURE 1: VIEW OF INSTALLATION OF THE DEF TANK SUPPORT BRACKET**

12. Drill 0.261-.0274" diameter hole, secure bracket and install rivet (**PN: 071992**). Crimp rivet in place.
13. Repeat process for the remaining 4 holes and install the remaining rivets.
14. Re-install any components and electrical harnesses at the ground plate. If re-connecting harness cables to ground plate, clean to bare metal and torque to **30 -37 FT/LBS dry**. Add di-electric grease after torquing connections.

**Note: For application of the zinc primer and undercoating, refer to Appendix D & E for application and TD sheets.**

15. If there is any bare metal around the area, touch up zinc primer and apply 2 thin coats. Follow Appendix C for application instructions.
16. After primer has dried, apply at least 2 thin coats of undercoating. Follow application instructions in Appendix D.
17. Remove jack stands and lower the bus per the service manual.

***Note: Only trained personnel can operate lifts. Follow safety instructions written on the lift and NF service manual.***



**NEW FLYER**

18. Turn the main battery disconnect switch to the “ON” position.
19. Fill in the ITS implementation sheet. One form must be completed for every unit that is serviced. This should be included with the claim form when the bus has been completed.



**IMPLEMENTATION OF NEW FLYER ITS 58838**

Bus Number: \_\_\_\_\_

Hub Reading: \_\_\_\_\_

Date Work Completed: \_\_\_\_\_

Assigned Welder: \_\_\_\_\_ (if required)

Service Tech: \_\_\_\_\_

Maximo Mileage: \_\_\_\_\_

New Flyer Industries hereby certified that the repairs completed on this bus were completed in accordance with approved ITS 58838 and the bus is structurally fit for service.

NF Representative:

Date:

\_\_\_\_\_

\_\_\_\_\_

Weld or Service Technician:

Date:

\_\_\_\_\_

\_\_\_\_\_



## Appendix A

### Stainless Steel welding procedure

- I. Temperature of steel parts to be welded must be at or above 68°F (20°C) before welding.
- II. Gas-shielded MIG welder using ER308LSi wire. GMAW shielding gas must conform to that specified on the applicable WPDSs (98%Ar - 2% CO<sub>2</sub> required).
- III. It is recommended to clean the area prior to welding with a stainless-steel brush to remove oxidation.

## **APPENDIX B**

### **WELD CRACK REPAIR PROCEDURE**

**(USE ONLY IF REQUIRED)**



Locate the crack site

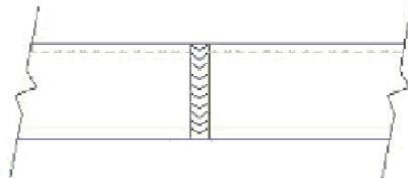

Ensure root opening as specified in applicable WPDS. Weld all cracks.

**NOTE: DRILL 0.25" DIAMETER HOLE AT THE END OF THE CRACK.**

- I. Determine origin and terminus of crack using either the Liquid Penetrant Test method or an equally positive means. Magnetic Particle Testing is not applicable on the austenitic stainless-steel component (#827849).
- II. Excavate and remove entire crack with rotary grinding equipment. **Ensure underlying frame rail material is not engaged with excavation process.** Thermal processes (e.g. OFC, PAC) shall not be used. Prepare weld joint as specified on applicable approved WPDS.





**NEW FLYER**

- III. Weld personnel shall meet qualification requirements IAW CSA W47.1/W59 for gas metal arc welding and the requirements of the applicable WPDS which include vertical down weld position.
- IV. Ensure weld machine ground cable is attached within close proximity to the weld zone.

## **Appendix C**

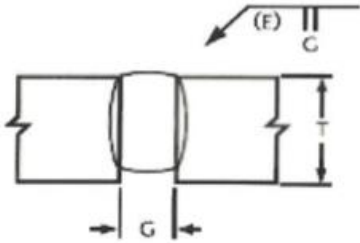
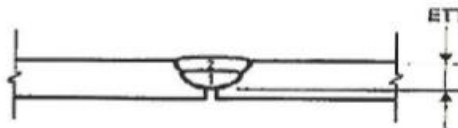

### **Welding Information Sheets**

WELDING PROCEDURE DATA SHEET									
Company Name: <b>New Flyer Industries / New Flyer of America Inc</b>				WPDS #: <b>3P-GSGa SS GMAW 035</b>					
711 Kernaghan Ave. Winnipeg, MB, R2C 3T4		6200 Glenn Carlson Dr, St Cloud, MN, 56301 USA		214 5th Avenue SW, Crookston, MN, 56716 USA		106 National Drive, Anniston, AL, 36207 USA		Date: <b>27-Feb-2017</b>	
						WPS: <b>NF-3</b>		Reference Standards: <b>CSA W47.1, AWS D1.6</b>	
Weld Process: <b>GMAW - Pulsed</b>		Weld Position: <b>Vertical Down</b>		Shielding Gas: <b>98%Ar-2%CO<sub>2</sub></b>					
Base Material: <b>Austenitic Stainless Steel per Table 5.2 AWS D1.6</b>		Process Mode: <b>Semi-Automatic</b>		Shielding Gas Flow Rate: <b>30-35 CFH</b>					
Filler Metal: <b>AWS 5.9, ER308LSi</b>		Preheat Temperature: <b>50° F min</b>		Interpass Temperature (min): <b>50° F</b>		Interpass Temperature (max): <b>N/A</b>			
Typical Joint Preparation:					Typical Pass and Layer Sequence:				
									
Joint Dimensions:		G: <b>0.035</b>		Electrode Stickout: <b>3/8" ± 1/8"</b>		Weld Type: <b>PJP Square Groove</b>			
Q: <b>N/A</b>		Nozzle Diameter: <b>5/8" - 3/4"</b>		Current Polarity: <b>DC+</b>		Joint Type: <b>Butt / Corner / Edge</b>			
Root Face (Rf): <b>N/A</b>						Pulse Program: <b>Miller 'Pulsed MIG' (Invision 350 MPa Power Source)</b>			
Material Thickness (t) (in)	Weld Size / ETT (in)	Number of Layers	Number of Passes	Electrode Diameter (in)	Peak / Background Current (A):	RMS Current (A)	Wire Feed Speed (in/min)	Voltage (V)	Travel Speed (in/min)
0.06 (16 ga)	0.060	1	1	0.035	200 / 100	150 - 180	425 - 475	21.5 - 24.5	18 - 24
0.075 (14 ga)	0.075	1	1	0.035	200 / 100	150 - 180	425 - 475	21.5 - 24.5	18 - 24
0.105 (12 ga)	0.105	1	1	0.035	200 / 100	150 - 180	425 - 475	21.5 - 24.5	18 - 24
0.120 (11 ga)	0.120	1	1	0.035	200 / 100	150 - 180	425 - 475	21.5 - 24.5	18 - 24
0.135 (10 ga)	0.135	1	1	0.035	200 / 100	150 - 180	425 - 475	21.5 - 24.5	18 - 24
0.187 (7 ga)	0.160	1	1	0.035	200 / 100	150 - 180	425 - 475	21.5 - 24.5	18 - 24
Revision Date: <b>27-Feb-2017</b>		Initials: <b>BSE</b>		Explanation: <b>Original WPDS</b>		Company Authorization:		CWB Approval:	
Per PQR 68BH1707260813 (macros)		Per PQR 68BH1707230725 (mechanicals)				<div style="border: 1px solid black; padding: 5px; width: fit-content; margin: 0 auto;"> <p>On the basis of <b>PROCEDURE QUALIFICATION</b></p> </div> <div style="border: 1px solid black; padding: 5px; width: fit-content; margin: 5px auto;">  <p><b>CWB Accepted</b> November 02, 2017</p> </div> <p style="font-size: small; text-align: center;">Valid only if welding consumables are certified by the CWB</p>			
Prepared by: <b>BSE Welding Engineering Ltd</b>									

**NEW FLYER INDUSTRIES**  
 711 Kernaghan Avenue  
 Winnipeg, MB R2C 3T4

**NEW FLYER USA**  
 6200 Glenn Carlson Drive  
 St. Cloud, MN 58301

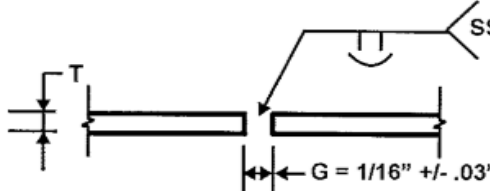
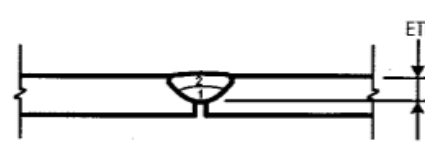
Date  
 27/10/05

<b>Process</b> <input type="checkbox"/> SMAW <input type="checkbox"/> FCAW <input checked="" type="checkbox"/> GMAW <input type="checkbox"/> SAW <input type="checkbox"/> GTAW	<b>Position</b> Vertical Down	<b>Applicable Codes</b> AWS D1.6 CSA W47.1, W59	<b>W.P.D.S. NO.</b> SS-9-GS																																																																																		
	<b>Polarity</b> DC +	<b>ESO</b> 1/2"-5/8"	<b>Welding Procedure Specification</b> NF-3																																																																																		
<b>Preheat temperature</b> Preheat min. per CSA W59 Min. Interpass Temperature: 60°F Max. Interpass Temperature: 200°F		<b>Material</b> Austenitic Stainless Steel Per Table 3.2 AWS D1.6	<b>Shielding Gas</b> 98% Ar. 2% CO <sub>2</sub>	<b>Flow Rate</b> 32-40 CFH																																																																																	
<div style="display: flex; justify-content: space-around;"> <div style="text-align: center;">  <p>Typical joint preparation</p> </div> <div style="text-align: center;">  <p>Typical pass sequence</p> </div> </div>																																																																																					
<b>Complete joint penetration groove weld</b> <input type="checkbox"/> Back gouge to sound metal <input type="checkbox"/> Welded onto steel backing		<input type="checkbox"/> Welded onto other than steel backing <input type="checkbox"/> Welded both sides, no back gouge	<input type="checkbox"/> Fillet Weld <input type="checkbox"/> Flare Bevel <input type="checkbox"/> Flare Vee <input checked="" type="checkbox"/> Partial joint penetration groove weld	<b>Joint type</b> <input checked="" type="checkbox"/> Butt <input type="checkbox"/> Tee <input checked="" type="checkbox"/> Corner <input checked="" type="checkbox"/> Edge <input type="checkbox"/> Lap																																																																																	
<table border="1"> <thead> <tr> <th>Size T</th> <th>Layer</th> <th>ETT</th> <th>Pass No.</th> <th>Electrode Size</th> <th>Amperes</th> <th>Wire Feed Speed</th> <th>Volts</th> <th>Travel Speed</th> </tr> </thead> <tbody> <tr><td>.060</td><td>1</td><td>.045</td><td>1</td><td>.035</td><td>131</td><td>310</td><td>18</td><td>25-28 ipm</td></tr> <tr><td>.075</td><td>1</td><td>.050</td><td>1</td><td>.035</td><td>131</td><td>310</td><td>18</td><td>22-26 ipm</td></tr> <tr><td>.100</td><td>1</td><td>.070</td><td>1</td><td>.035</td><td>131</td><td>310</td><td>18</td><td>20-24 ipm</td></tr> <tr><td>.120</td><td>1</td><td>.080</td><td>1</td><td>.035</td><td>131</td><td>310</td><td>18</td><td>30-35 ipm</td></tr> <tr><td>.134</td><td>1</td><td>.090</td><td>1</td><td>.035</td><td>166</td><td>400</td><td>22.5</td><td>28-32 ipm</td></tr> <tr><td>.1875</td><td>1</td><td>.130</td><td>1</td><td>.035</td><td>166</td><td>400</td><td>22.5</td><td>31.3 ipm</td></tr> <tr><td>.1875</td><td>1</td><td>*.093</td><td>1</td><td>.035</td><td>166</td><td>400</td><td>22.5</td><td>42.1 ipm</td></tr> <tr><td>.250</td><td>1-2</td><td>.180</td><td>1-2</td><td>.035</td><td>166</td><td>400</td><td>22.5</td><td>18-22 ipm</td></tr> </tbody> </table>	Size T	Layer	ETT	Pass No.	Electrode Size	Amperes	Wire Feed Speed	Volts	Travel Speed	.060	1	.045	1	.035	131	310	18	25-28 ipm	.075	1	.050	1	.035	131	310	18	22-26 ipm	.100	1	.070	1	.035	131	310	18	20-24 ipm	.120	1	.080	1	.035	131	310	18	30-35 ipm	.134	1	.090	1	.035	166	400	22.5	28-32 ipm	.1875	1	.130	1	.035	166	400	22.5	31.3 ipm	.1875	1	*.093	1	.035	166	400	22.5	42.1 ipm	.250	1-2	.180	1-2	.035	166	400	22.5	18-22 ipm	<p>* Gap=.07</p>			
Size T	Layer	ETT	Pass No.	Electrode Size	Amperes	Wire Feed Speed	Volts	Travel Speed																																																																													
.060	1	.045	1	.035	131	310	18	25-28 ipm																																																																													
.075	1	.050	1	.035	131	310	18	22-26 ipm																																																																													
.100	1	.070	1	.035	131	310	18	20-24 ipm																																																																													
.120	1	.080	1	.035	131	310	18	30-35 ipm																																																																													
.134	1	.090	1	.035	166	400	22.5	28-32 ipm																																																																													
.1875	1	.130	1	.035	166	400	22.5	31.3 ipm																																																																													
.1875	1	*.093	1	.035	166	400	22.5	42.1 ipm																																																																													
.250	1-2	.180	1-2	.035	166	400	22.5	18-22 ipm																																																																													
<table border="1"> <thead> <tr> <th>Revision Date</th> <th>Initials</th> <th>Explanation</th> </tr> </thead> <tbody> <tr> <td>Oct 05</td> <td>FAR</td> <td>P35334</td> </tr> <tr> <td>Oct 27/05</td> <td>FAR</td> <td>Settings for .120"</td> </tr> </tbody> </table>	Revision Date	Initials	Explanation	Oct 05	FAR	P35334	Oct 27/05	FAR	Settings for .120"			<div style="border: 1px solid black; padding: 5px;"> <p>Welding Procedure Data Sheet            CWB Accepted to CSA W47.1</p> <p>NOV 03 2005</p> <p>Acceptance valid only when Welding Consumables certified by C.W.B. (Cl. 11.8.1, CSA W47.1)</p> </div>																																																																									
Revision Date	Initials	Explanation																																																																																			
Oct 05	FAR	P35334																																																																																			
Oct 27/05	FAR	Settings for .120"																																																																																			



## Appendix D

### ZINC PRIMER



**NF PN: 606945 & 638699**

Page 1 of 4

#### **General Industrial**

#### **Technical Data Sheet**

GANICIN™ 2.8 MC-U™ MOISTURE-CURED ZINC-RICH PRIMER

# **Ganicin™ 2.8 MC-U**

## **Moisture-Cured Zinc-Rich**

## **Polyurethane Primer**

#### **GENERAL**

#### **DESCRIPTION**

A high solids, two-component, 2.8 lbs/gal VOC conforming, moisture-cured organic zinc-rich coating based on Axalta polyurethane technology. The resulting coating is designed to be highly durable and to deliver outstanding corrosion resistance.

#### **SUGGESTED USES**

As a high performance primer on carbon steel or as a touch-up for inorganic zinc coatings where:

- A coating with 85% zinc in the dried film with low VOC is required
- Spray application, or by brush when touch-ups may be necessary
- Application is recommended down to 35°F (2°C)
- No induction time and long pot life may improve productivity

Ganicin 2.8 MC-U is intended to be used as a primer and should be topcoated.

#### **COMPATIBILITY WITH OTHER COATINGS**

Ganicin 2.8 MC-U Moisture-Cured Zinc-Rich Primer may be topcoated with Corlar® epoxies and/or Imron® polyurethane Primers. Do not apply Imron polyurethane topcoats, directly to Ganicin 2.8 MC-U. Ganicin 2.8 MC-U may also be used to touch up inorganic and organic zinc-rich coatings. Testing for lifting, bubbling and adhesion is recommended to assure compatibility with unknown coatings. Contact your Axalta representative for specific recommendations.

#### **NOT RECOMMENDED FOR**

- Immersion service
- Exposure to acid or alkali environments without suitable topcoats

#### **PERFORMANCE PROPERTIES**

Chemical Excellent

Humidity Excellent

Water spray Excellent

Weather Excellent with durable topcoat  
(will chalk if left untopcoated)

#### **COLOR**

Grey green

The products referenced herein may not be sold in your market. Please consult your distributor for product availability.



## MIXING

### COMPONENTS

63P1500 primer base 1 short fill gallon container (0.46 gallon)  
347YB1500™ zinc dust 1 gallon container (13.4 lbs.)

### MIX RATIO

#### Component Part by Volume

63P1500 primer base 1 container short fill (0.46 gallon)  
347YB1500 zinc dust 1 container (13.4 lbs.)

NOTE: Mixed amount will makes 0.70 gallon.

Page 2 of 4

## General Industrial

### Technical Data Sheet

GANICIN™ 2.8 MC-U™ MOISTURE-CURED ZINC-RICH PRIMER

### ACTIVATION

Thoroughly stir 63P1500 primer, then slowly add 347YB1500 zinc dust with consistent agitation. After mixing, filter through a 40 mesh screen. Filter into an agitated spray pot. Constant agitation during application is recommended to prevent settling of zinc dust. Minimize contact with humid air.

### Reduction

No reduction should be necessary. However, if conditions require thinning, Axalta 8685S™ may be used up to 5 oz./gal. To remain @ 2.8 lbs/gal VOC, use no more than 2 oz/gal.

### APPLICATION THINNERS

Spray or brush: Axalta 8685S up to 2 oz./gal. may be added and still remain conforming at 2.8 lbs/gal VOC. Amounts up to 5 oz./gal. Max can be used if required for various application conditions. Use no alcohol-containing thinners.

### POT LIFE

At least 8 hours if moisture is excluded, shorter in high humidity and temperature.

## APPLICATION

### SURFACE PREPARATION

An SSPC-SP 6 Commercial Blast Cleaning is preferred for optimal performance. For touchup over inorganic zinc, Hand Tool Clean to an SSPC-SP 2 or Power Tool Clean to an SSPC-SP 3 can be used. Note: You can prep surface by using 100 – 150 grit sand paper.

### APPLICATION CONDITIONS

Do not apply if material, substrate or ambient temperature is below 35°F (2°C) or above 110°F (43°C). The substrate must be at least 5°F (3°C) above the dew point. Relative humidity should be below 90%. For best results, apply by spray. Product can be brushed for small spot applications or repairs. Note that in high humidity, the coating will gradually accumulate on the brush.

### BRUSH APPLICATION

Manufacturer: Wooster China Bristle - 3"- 4" brush

### SPRAY APPLICATION

Manufacturers listed below are a guide. Others may be used. Changes in tip size or pressure may be required to achieve proper application.

#### Conventional Spray

Binks DeVilbiss  
Spray Gun: 2001 JGA  
Fluid Nozzle: 67SS FF (1.4)  
Air Cap: 67PR 704

#### HVLP Spray

Binks DeVilbiss  
Spray Gun: Mach 1 GTi  
Fluid Nozzle: 94 (1.4) 1.4  
Air Cap: 94P 2000

#### Airless Spray

Pump: Graco Extreme 33:1  
Airless Gun: Graco 946853  
Fluid Hose: 3/8" x 100' max.  
Tips: 415-517RAC

Minimum pressure to avoid fingering: 2400 psi min.

Page 3 of 4

## General Industrial

### Technical Data Sheet

GANICIN™ 2.8 MC-U™ MOISTURE-CURED ZINC-RICH PRIMER



### Application Notes

- Must be agitated during application.
- For conventional air spray, fluid lines should be 0.5" inner diameter and 25-50' long maximum.
- For best results, keep pressure pot at the same height as the work.
- Apply a full, wet coat. Try not to exceed specified film build thickness.

### CLEAN UP THINNERS

Axalta 8685S

### DRY TIMES

Cure time at recommended thickness 3 mils DTF @ 50% RH

77°F (25°C)

To touch 30 minutes

Re-coat 2 hours

Handle 3-4 hours

Note: May be overcoated with itself up to 3 days (72 hours) after initial application.

### PHYSICAL PROPERTIES

Maximum Service Temperature 250°F (121°C) in continuous service

350°F (177°C) in intermittent service

Volume Solids 62% ± 2%

Weight Solids 89% ± 2%

Theoretical Coverage Per Gallon 994 ft<sup>2</sup> (24.4 m<sup>2</sup>/L) @ 1 mil DFT

330 ft<sup>2</sup> (8.1 m<sup>2</sup>/L) @ 3 mils DFT

Material losses during mixing and application will vary and must be taken into consideration when estimating job requirements.

Weight Per Gallon 24.8 lb average | 11.2 kg. average

Shipping Weight (approximate) 1 gallon container: liquid 3.8 lbs | zinc 13.4 lbs

Suggested Film Thickness 5 mils (125 µm) wet

3 mils (75 µm) dry

Application by brush and roller may require additional coats to achieve recommended films thickness.

Flash Point: (Tag Closed Cup) 100°F (38°C)

Gloss Flat

Package Size 1 container

Shelf Life 1 year minimum

### STORAGE CONDITIONS

Store in a dry, well-ventilated area. Storage conditions should be between -30°F (-34°C) and 120°F (48°C).

Moisture-cured zinc-rich primer liquid may settle. Agitate before each use. To prevent pressure build-up after mixing, do not store in sealed containers.

### VOC REGULATIONS

VOC (Theoretical, varies with color).

Moisture cured zinc-rich primer; unreduced 2.76 lbs/gal (332 g/l)

These directions refer to the use of products which may be restricted or require special mixing instructions in VOC regulated areas. Follow mixing usage and recommendations in the VOC Compliant Products Chart for your area.

Page 4 of 4

### General Industrial

#### Technical Data Sheet

GANICIN™ 2.8 MC-U™ MOISTURE-CURED ZINC-RICH PRIMER

### ASTM INFORMATION

Physical properties are for Ganicin 2.8 MC-U Moisture-Cured Zinc-Rich Primer. For other system results, contact Axalta Coating Systems.

Paint System: Ganicin 2.8 MC-U

Type | Color: Moisture-cure organic zinc-rich | Gray green

DFT: 2.8 mils

Salt Fog (ASTM B117) 1000 hours no rusting, no blisters

2000 hours no rusting, no blisters

3000 hours no rusting, few #8 blisters at the scribe, no undercutting at the scribe

Relative Humidity (ASTM D2247) 1000 hours no rusting, no blisters

2000 hours no rusting, no blisters

3000 hours no rusting, no blisters

Dry Heat (ASTM D2485) 250°F for 24 hours no cracking, no blisters, moderate loss of adhesion, no discoloration



## NEW FLYER

Electrical Resistance:  $1 \times 10^{10}$  (OHMS)

Adhesion (ASTM D4541): 2406 psi cohesive failure within the coating

Cleveland Cond (ASTM D4585): 1000 hours no rusting, no blisters

UV Con (ASTM D4587)\* 3000 hours Gloss before exposure: 2

Gloss after exposure: 0.9

Evaluation no rusting, no blisters, no delamination

Mandrel Bend (ASTM D522): % Elongation – 5-10% (on smooth eCoat)

Taber Abrasion (ASTM D4060): weight loss in grams - 0.14

\*8 hr UV @ 122°F (50°C), 4 hr condensation @ 104°F (40°C), gloss readings @ 60°

### **SAFETY AND HANDLING**

For industrial use only by professional, trained painters. Not for sale to or use by the general public. Before using, read and follow all label and MSDS precautions. If mixed with other components, mixture will have hazards of all components. Ready to use paint materials containing isocyanates can cause irritation of the respiratory organs and hypersensitive reactions. Asthma sufferers, those with allergies and anyone with a history of respiratory complaints must not be asked to work with products containing isocyanates.

Do not sand, flame cut, braze or weld dry coating without a NIOSH approved air purifying respirator with particulate filters or appropriate ventilation, and gloves.

All technical advice, recommendations and services are rendered by the Seller gratis. They are based on technical data which the Seller believes to be reliable, and are intended for professional use by persons having skill and know-how at their own discretion and risk. Seller assumes no responsibility for results obtained or damages incurred from their use by Buyer in whole or in part. Such recommendations, technical advice or services are not to be taken as a license to operate under or intended to suggest infringement of any existing patent.

**Revised: June 2015**

**In the United States:**

**1.855.6.AXALTA**

**axalta.us**

**In Canada:**

**1.800.668.6945**

**axalta.ca**

© 2015 Axalta Coating Systems, LLC and all affiliates. All rights reserved.



**APPENDIX E:**  
UNDERCOATING



NF PN: 606947

Page 1 of 3

**Transportation**

Technical Data Sheet

TUFCOTE™ UC-1000™

**Tufcote™ UC-1000™**

**Waterborne Chip Resistant Undercoat**

**GENERAL**

**DESCRIPTION**

A single-component, waterborne, zero VOC, semi-firm coating designed to deliver premium performance to resist chipping, scratches and gravel marks for use on the underbody of truck, trailer, bus, body builder and other transit vehicles. It is formulated to provide excellent adhesion, hardness and may be applied at film thickness up to 15 mils. It is available in three factory packaged colors: black, off-white, and grey.

**SUGGESTED USES**

- Recommended for use on underbody of truck, trailer, bus, body builder and other transit vehicles where premium quality attributes for corrosion prevention and chip resistance are desired.
- Formulated to provide excellent adhesion, hardness and durability to most substrates including primers, e-coat and oily steel.

**COMPATIBILITY WITH OTHER COATINGS**

- Compatible with most urethane, acrylic or alkyd resin formulated transportation quality topcoats

**COLOR**

UC-1001™ Black

UC-1003™ Grey

UC-1006™ White

**MIXING**

**COMPONENT**

Tufcote UC-1000 Waterborne Chip Resistant Undercoat

**MIX RATIO**

Mixing or thinning not required. Mild agitation is recommended prior to use.

**ADDITIVES**

None recommended.

DO NOT THIN. Incorrect thinning will affect film build, dry time and product performance.

**APPLICATION**

**SURFACE PREPARATION**

The maximum performance of Tufcote UC-1000 can be achieved only when the metal surfaces to be protected are clean, dry, and free of rust, oil, and mill scale.

**APPLICATION CONDITIONS**



## NEW FLYER

Do not apply if material, substrate or ambient temperature is less than 50°F (10°C) or above 95°F (35°C) at the time of product application.

### APPLICATION EQUIPMENT

Airless spray

Dip

Page 2 of 3

### Transportation

#### Technical Data Sheet

TUFCOTE™ UC-1000™

### APPLICATION

- Tufcote UC-1000 is formulated to be used as supplied.
- Ensure uniform consistency prior to use. Continued stirring is generally not required.
- If the product thickens due to cold storage or loss of water and coalescing solvent during use, contact an Axalta representative.
- DO NOT THIN. Incorrect thinning will affect film build, dry time and product performance.
- Recommended ambient and product temperature should be 50 - 95°F (10 - 35°C) at time of application.
- Product can be airless spray or dip applied.

### RE-COAT

- Tufcote UC-1000 may be recoated with most urethane, acrylic or alkyd resin formulated transportation topcoats.

### REMOVAL

The dry film is not normally intended for removal. The product can be repainted after the film is cured. Citrus or alkaline cleaner will remove fresh residue accumulated on application equipment. If removability is a factor, contact an Axalta representative.

### CLEAN UP SOLVENTS

Citrus or alkaline cleaner

### DRY TIMES

Approximate Dry Time At Recommended Thickness @ 77°F (25°C)

Air dry 30 – 60 minutes

Cure Time 72 hours

- Adequate ventilation is required for cure and to ensure against formation of a combustible liquid atmosphere.
- THE PARTIALLY CURED FILM SHOULD NOT BE EXPOSED TO IGNITION SOURCES SUCH AS FLARES, FLAMES, SPARKS, EXCESSIVE HEAT, OR TORCHES.
- Refer to product Material Safety Data Sheet for additional handling and first aid information.

### PHYSICAL PROPERTIES

UC-1001 UC-1003 UC-1006

Black Grey White

Density, Weight/Gallon @ 77°F (25°C) 10.5 ± 0.1 lbs 10.9 ± 0.1 lbs 10.9 ± 0.1 lbs

Recommended Dry Film Thickness

over Metal Profile 10 - 15 mils 10 - 15 mils 10–15 mils

Dry Film Thickness Over Primed Steel 6 – 8 mils 6 – 8 mils 6 – 8 mils

Theoretical Coverage @ Rec. DFT 48-73 ft<sup>2</sup>/gallon 75-95 ft<sup>2</sup>/gallon 80 ft<sup>2</sup>/gal

Non-Volatile % by Weight 55 ± 2 56 ± 2 54 ± 2

Non-Volatile % by Volume 45 ± 2 42 ± 2 50 ± 2

Gloss Matte

Shelf Life 12 months minimum

Gravelometer, -20°C, SAE J-400, Pass, Excellent Rating

GM-998-4247, GM9508P No Adhesion Loss

Page 3 of 3

### Transportation

#### Technical Data Sheet

TUFCOTE™ UC-1000™



### **STORAGE CONDITIONS**

Store in a dry, well-ventilated area. Storage conditions should be between 50°F (10°C) and 95°F (35°C). Mild agitation is recommended prior to use.

Do not allow product to freeze.

### **ASTM INFORMATION**

5% Salt Spray (Hours) at 15 mils DFT

ASTM B-117 @ 6 to 10 Recommended DFT 2000

(2x4x1/8 in. CRS Panels)

100% Relative Humidity (Hours)

ASTM D-1748 @ Recommended DFT 1000

(2x4x1/8 in. CRS Panels)

### **VOC REGULATIONS**

Volatile Organic Content (VOC) 0 lbs. / gallon

### **SAFETY AND HANDLING**

For industrial use only by professional, trained painters. Not for sale to or use by the general public. Before using, read and follow all label and MSDS precautions. If mixed with other components, mixture will have hazards of all components.

Ready to use paint materials containing isocyanates can cause irritation of the respiratory organs and hypersensitive reactions. Asthma sufferers, those with allergies and anyone with a history of respiratory complaints must not be asked to work with products containing isocyanates.

Do not sand, flame cut, braze or weld dry coating without a NIOSH approved air purifying respirator with particulate filters or appropriate ventilation, and gloves.

All technical advice, recommendations and services are rendered by the Seller gratis. They are based on technical data which the Seller believes to be reliable, and are intended for professional use by persons having skill and know-how at their own discretion and risk. Seller assumes no responsibility for results obtained or damages incurred from their use by Buyer in whole or in part. Such recommendations, technical advice or services are not to be taken as a license to operate under or intended to suggest infringement of any existing patent.

**Revised: February 2015**

**In the United States:**

**1.855.6.AXALTA**

**axalta.us**

**In Canada:**

**1.800.668.6945**

**axalta.ca**

© 2015 Axalta Coating Systems, LLC and all affiliates. All rights reserved.





## NEW FLYER

### LABOUR ESTIMATE

	Operation	Men	Hours	Labour Time M X HR
1	Bring in & set up coach. Connect & disconnect all electrical modules required. This includes the 3 connection points on the DPIM on roof (only if bus is Hybrid). Note: This is only for buses that have weld cracks to repair.	1	1.5	1.5
1A	Prep area and weld up cracks.	1	1.0	1.0
2	Install DEF tank support bracket.	1	1	1

**Note:**

***Buses that have cracked welds, total labor: 3.5 hours***  
***Or***

***Buses that have no cracks, total labor: 1.0 hour***

### PARTS REQUIRED

Item	Part Number	Description	Qty. per Coach	Units	Notes
1	827849	Bracket – Support, Def tank	1	EA	
2	071992	Rivet – ¼ SS .08-.575GP	5	EA	
3	606945	Primer Zinc	0.01	GA	
4	638699	Primer Zinc Powder	0.01	GA	
5	638689	Solvent – Axalta Zinc Thinner	0.1	GA	*1
6	606947	Undercoat	0.1	EA	

**NOTE:**

- 1) *Equivalent thinner can be used as well.*