

# Technical Service Bulletin

Mazda North American Operations  
Irvine, CA 92618-2922



<b>Subject:</b>  <b>STEERING WHEEL OFF CENTER WITHOUT DRIFT OR PULL</b>	<b>Bulletin No.:</b> 02-003/20
	<b>Last Issued:</b> 01/23/2020

## BULLETIN NOTES

This bulletin supersedes the previously issued bulletin(s) listed below: The changes are noted in Red.

Previously issued TSBs:	Date(s) issued:	Previously issued TSBs:	Date(s) issued:
02-004/19	01/23/19	02-004/13	08/22/13 and 04/10/13
02-010/18	05/08/18	02-004/12	09/19/12 and 02/19/13
02-009/16	03/07/16	02-005/10	03/26/10 and 11/05/10
02-004/14	11/04/14		

## APPLICABLE MODEL(S)/VINS

2011-2014 Mazda2	2014-2020 Mazda6	2020 CX-30
2013-2020 Mazda3	2016-2020 CX-3	2016-2020 CX-9
2010-2015 Mazda5	2013-2020 CX-5	2016-2020 MX-5

## DESCRIPTION

Some customers may complain that the steering wheel is off center more than 3° even when driving straight on a flat road.

**CONSUMER NOTICE:** The information and instructions in this bulletin are intended for use by skilled technicians. Mazda technicians utilize the proper tools/equipment and take training to correctly and safely maintain Mazda vehicles. These instructions should not be performed by "do-it-yourselfers." Customers should not assume this bulletin applies to their vehicle or that their vehicle will develop the described concern. To determine if the information applies, customers should contact their nearest authorized Mazda dealership. Mazda North American Operations reserves the right to alter the specifications and contents of this bulletin without obligation or advance notice. All rights reserved. No part of this bulletin may be reproduced in any form or by any means, electronic or mechanical---including photocopying and recording and the use of any kind of information storage and retrieval system ---without permission in writing.

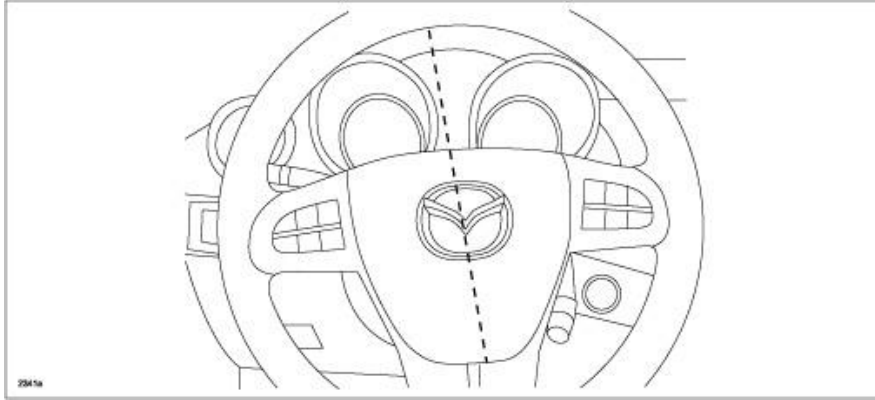

Customers having this concern should have their vehicle repaired using the following repair procedure.

## REPAIR PROCEDURE

1. Verify customer concern and make sure there is no drift or pull concern.
  - If the steering is pulling to the right or the left, this procedure does not apply. Refer to MGSS online instructions for troubleshooting.
2. Measure the offset using "Measurement of Steering Wheel Offset."
  - If the offset is 3° or less, it is considered normal.
  - If the offset is more than 3°, adjust the steering wheel center using "Adjustment of Steering Wheel Center."
3. Verify repair.

### Measurement of Steering Wheel Offset

4. Visually align the steering wheel to its center, then apply tape on the steering wheel and the steering column cover.

**CONSUMER NOTICE:** The information and instructions in this bulletin are intended for use by skilled technicians. Mazda technicians utilize the proper tools/equipment and take training to correctly and safely maintain Mazda vehicles. These instructions should not be performed by "do-it-yourselfers." Customers should not assume this bulletin applies to their vehicle or that their vehicle will develop the described concern. To determine if the information applies, customers should contact their nearest authorized Mazda dealership. Mazda North American Operations reserves the right to alter the specifications and contents of this bulletin without obligation or advance notice. All rights reserved. No part of this bulletin may be reproduced in any form or by any means, electronic or mechanical---including photocopying and recording and the use of any kind of information storage and retrieval system ---without permission in writing.

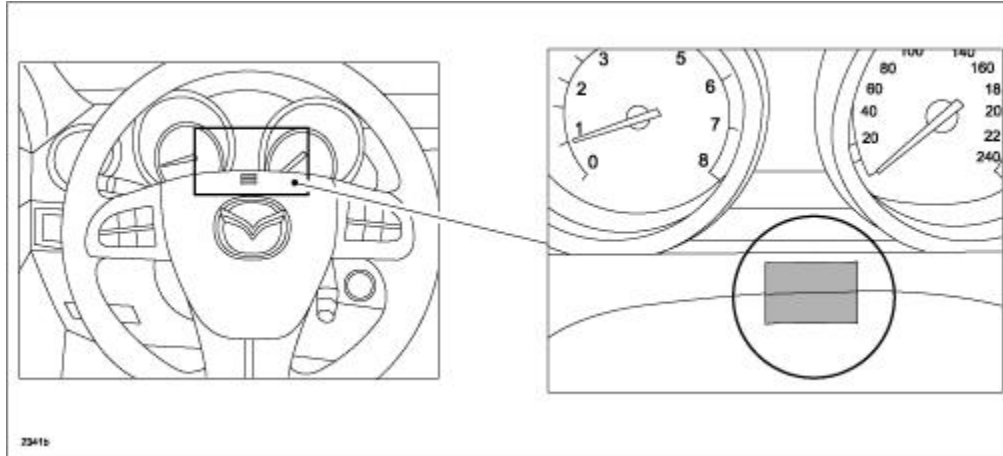

**CONSUMER NOTICE:** The information and instructions in this bulletin are intended for use by skilled technicians. Mazda technicians utilize the proper tools/equipment and take training to correctly and safely maintain Mazda vehicles. These instructions should not be performed by "do-it-yourselfers." Customers should not assume this bulletin applies to their vehicle or that their vehicle will develop the described concern. To determine if the information applies, customers should contact their nearest authorized Mazda dealership. Mazda North American Operations reserves the right to alter the specifications and contents of this bulletin without obligation or advance notice. All rights reserved. No part of this bulletin may be reproduced in any form or by any means, electronic or mechanical---including photocopying and recording and the use of any kind of information storage and retrieval system ---without permission in writing.

5. Put an alignment mark on the tape.

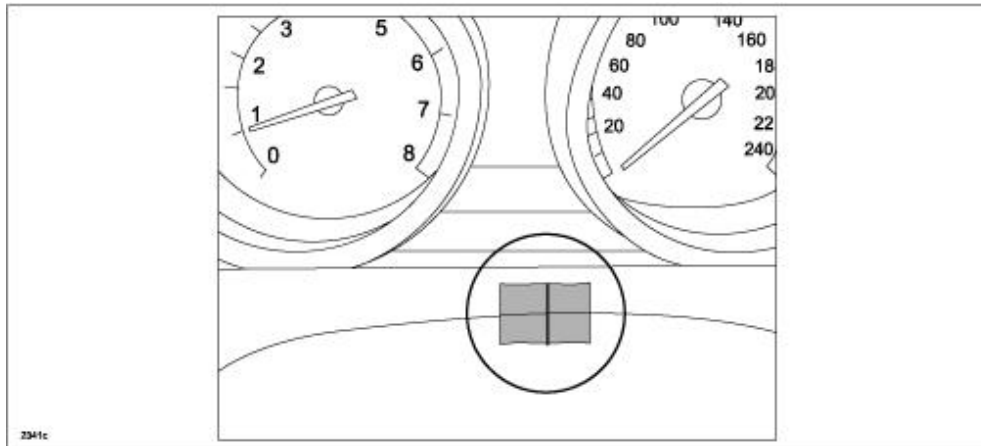

6. Drive the vehicle and align the steering wheel to its driving center, then put another mark on the tape.

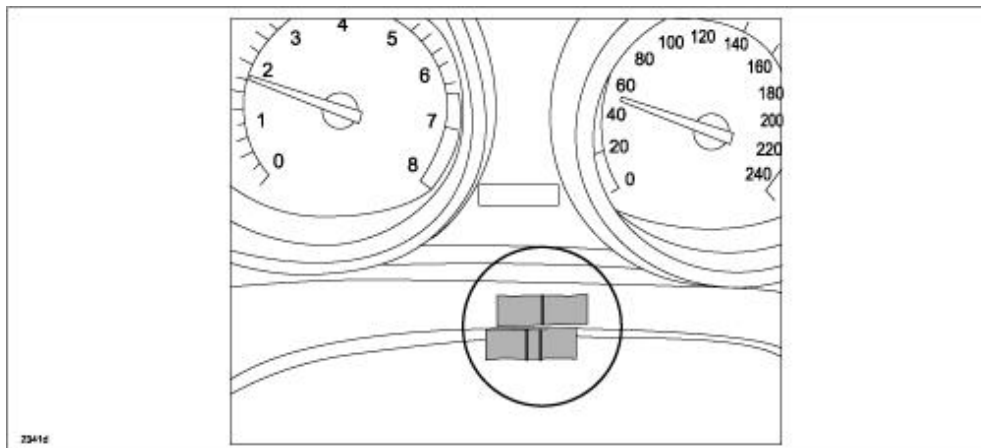

7. Measure the distance between the two lines. The offset can be approximately calculated using  $1\text{mm} = 1^\circ$  of offset.

**CONSUMER NOTICE:** The information and instructions in this bulletin are intended for use by skilled technicians. Mazda technicians utilize the proper tools/equipment and take training to correctly and safely maintain Mazda vehicles. These instructions should not be performed by "do-it-yourselfers." Customers should not assume this bulletin applies to their vehicle or that their vehicle will develop the described concern. To determine if the information applies, customers should contact their nearest authorized Mazda dealership. Mazda North American Operations reserves the right to alter the specifications and contents of this bulletin without obligation or advance notice. All rights reserved. No part of this bulletin may be reproduced in any form or by any means, electronic or mechanical---including photocopying and recording and the use of any kind of information storage and retrieval system ---without permission in writing.

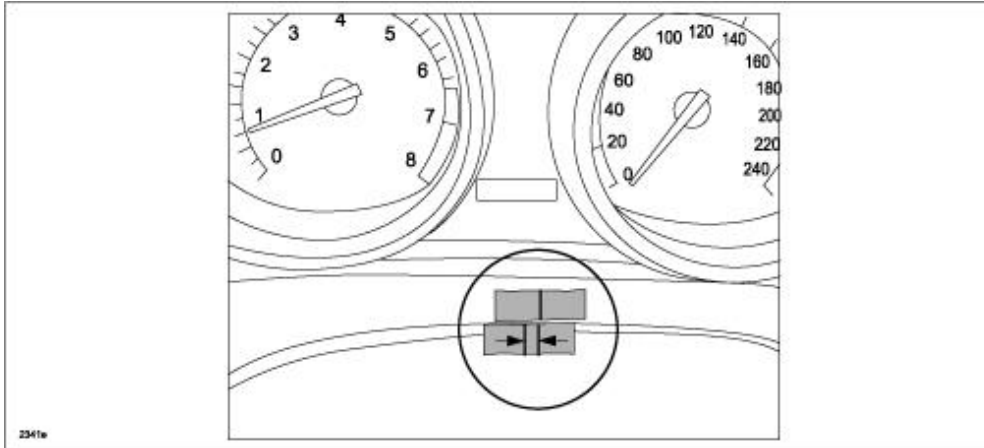

#### Adjustment of Steering Wheel Center

8. Put an alignment mark over the tie-rod end and tie-rod as shown.

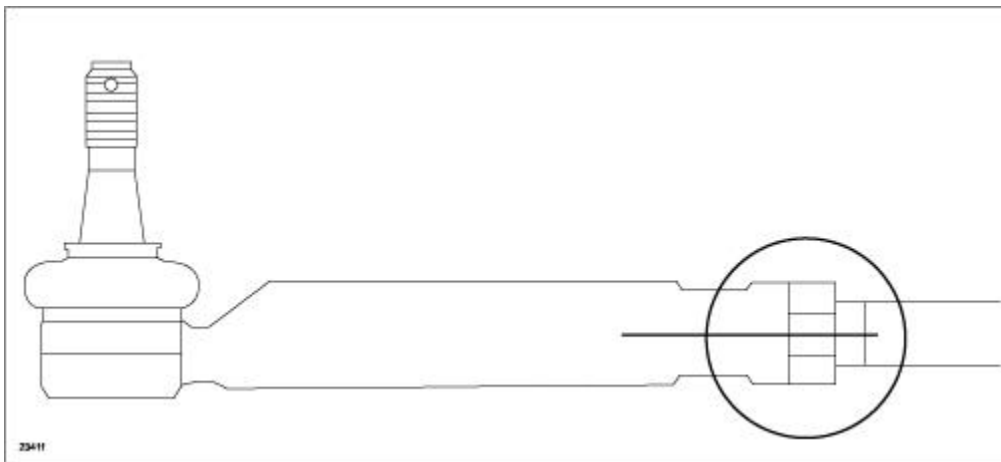

9. Remove the boot clamp (A), then loosen the lock nut (B).

**CONSUMER NOTICE:** The information and instructions in this bulletin are intended for use by skilled technicians. Mazda technicians utilize the proper tools/equipment and take training to correctly and safely maintain Mazda vehicles. These instructions should not be performed by "do-it-yourselfers." Customers should not assume this bulletin applies to their vehicle or that their vehicle will develop the described concern. To determine if the information applies, customers should contact their nearest authorized Mazda dealership. Mazda North American Operations reserves the right to alter the specifications and contents of this bulletin without obligation or advance notice. All rights reserved. No part of this bulletin may be reproduced in any form or by any means, electronic or mechanical---including photocopying and recording and the use of any kind of information storage and retrieval system ---without permission in writing.

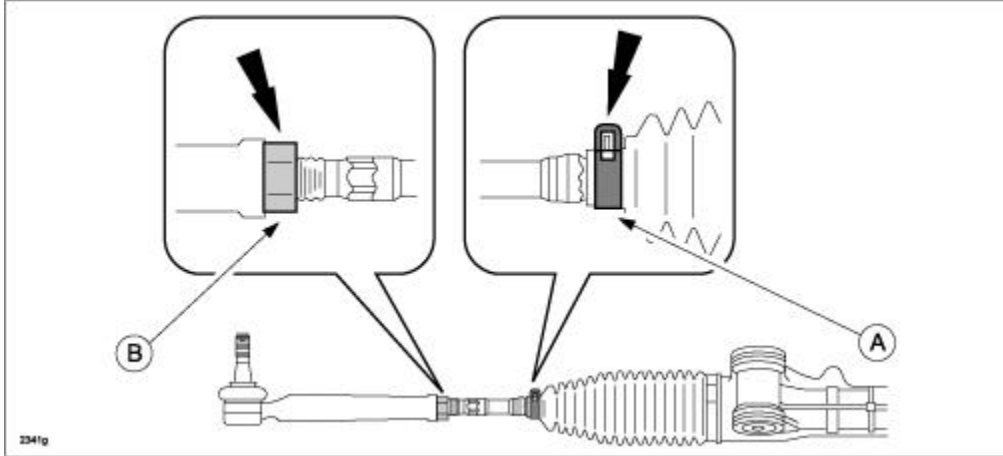

10. Rotate the tie-rod to adjust the steering wheel center. Refer to the following charts for rotating direction.

**NOTE:** Rotate both sides of the tie-rod by the same amount.

- Steering wheel offset direction and tie-rod rotating direction -

**CONSUMER NOTICE:** The information and instructions in this bulletin are intended for use by skilled technicians. Mazda technicians utilize the proper tools/equipment and take training to correctly and safely maintain Mazda vehicles. These instructions should not be performed by "do-it-yourselfers." Customers should not assume this bulletin applies to their vehicle or that their vehicle will develop the described concern. To determine if the information applies, customers should contact their nearest authorized Mazda dealership. Mazda North American Operations reserves the right to alter the specifications and contents of this bulletin without obligation or advance notice. All rights reserved. No part of this bulletin may be reproduced in any form or by any means, electronic or mechanical---including photocopying and recording and the use of any kind of information storage and retrieval system ---without permission in writing.

FRONT WHEEL DRIVE (Vehicles with steering gear mounted to the rear side of the front axle)

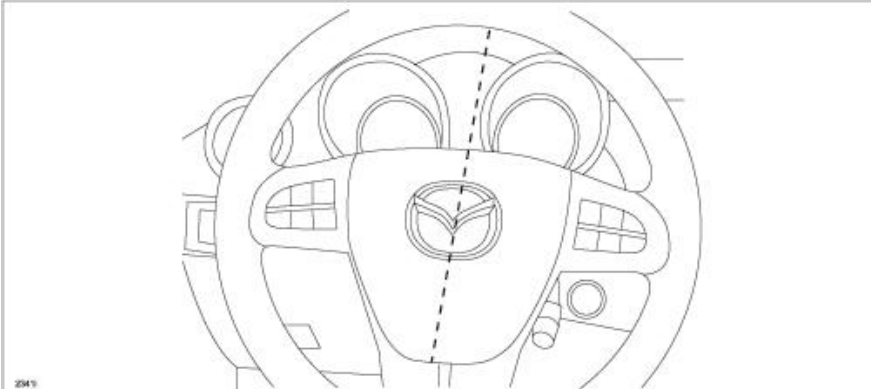
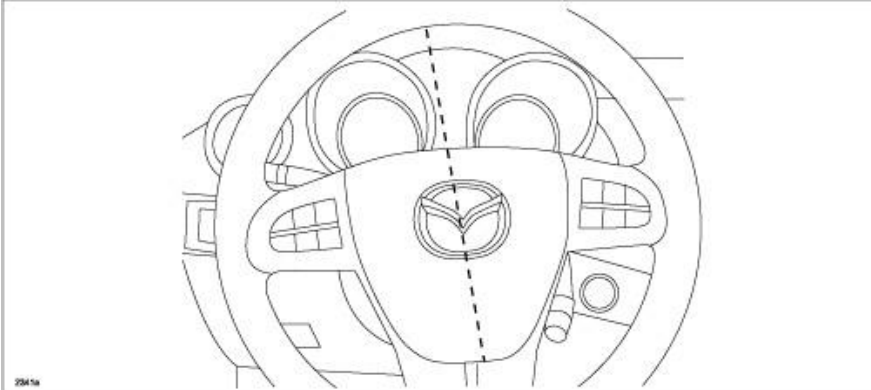
Steering wheel offset direction	Tie-rod adjust	Tie-rod rotating direction to adjust
<p style="text-align: center;">Right</p> 	Right side	Tighten the tie-rod towards the tie-rod end to decrease the length of the tie-rod.
	Left side	Loosen the tie-rod from the tie-rod end to increase the length of the tie-rod.
<p style="text-align: center;">Left</p> 	Right side	Loosen the tie-rod from the tie-rod end to increase the length of the tie-rod.
	Left side	Tighten the tie-rod towards the tie-rod end to decrease the length of the tie-rod.

**CONSUMER NOTICE:** The information and instructions in this bulletin are intended for use by skilled technicians. Mazda technicians utilize the proper tools/equipment and take training to correctly and safely maintain Mazda vehicles. These instructions should not be performed by "do-it-yourselfers." Customers should not assume this bulletin applies to their vehicle or that their vehicle will develop the described concern. To determine if the information applies, customers should contact their nearest authorized Mazda dealership. Mazda North American Operations reserves the right to alter the specifications and contents of this bulletin without obligation or advance notice. All rights reserved. No part of this bulletin may be reproduced in any form or by any means, electronic or mechanical---including photocopying and recording and the use of any kind of information storage and retrieval system ---without permission in writing.

REAR WHEEL DRIVE (Vehicles with steering gear mounted to the front side of the front axle)

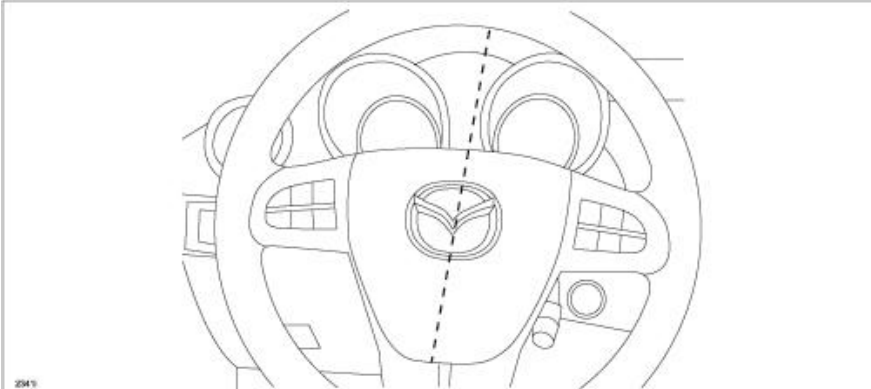
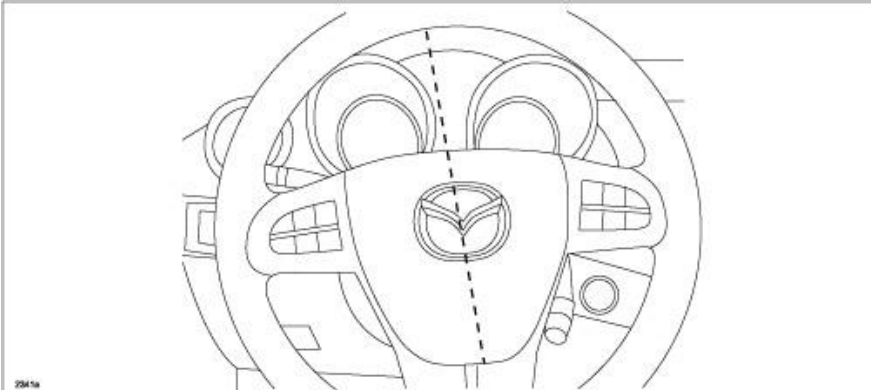
Steering wheel offset direction	Tie-rod adjust	Tie-rod rotating direction to adjust
<p style="text-align: center;">Right</p> 	Right side	Loosen the tie-rod from the tie-rod end to increase the length of the tie-rod.
	Left side	Tighten the tie-rod towards the tie-rod end to decrease the length of the tie-rod.
<p style="text-align: center;">Left</p> 	Right side	Tighten the tie-rod towards the tie-rod end to decrease the length of the tie-rod.
	Left side	Loosen the tie-rod from the tie-rod end to increase the length of the tie-rod.

**CONSUMER NOTICE:** The information and instructions in this bulletin are intended for use by skilled technicians. Mazda technicians utilize the proper tools/equipment and take training to correctly and safely maintain Mazda vehicles. These instructions should not be performed by "do-it-yourselfers." Customers should not assume this bulletin applies to their vehicle or that their vehicle will develop the described concern. To determine if the information applies, customers should contact their nearest authorized Mazda dealership. Mazda North American Operations reserves the right to alter the specifications and contents of this bulletin without obligation or advance notice. All rights reserved. No part of this bulletin may be reproduced in any form or by any means, electronic or mechanical---including photocopying and recording and the use of any kind of information storage and retrieval system ---without permission in writing.



- A: Tie-rod
- B: Lock nut
- C: Tie-rod end
- F: Front of vehicle

- 1: Turn in this direction to loosen the tie-rod from the tie-rod end and increase the length.
- 2: Turn in this direction to tighten the tie rod towards the tie-rod end and decrease the length.

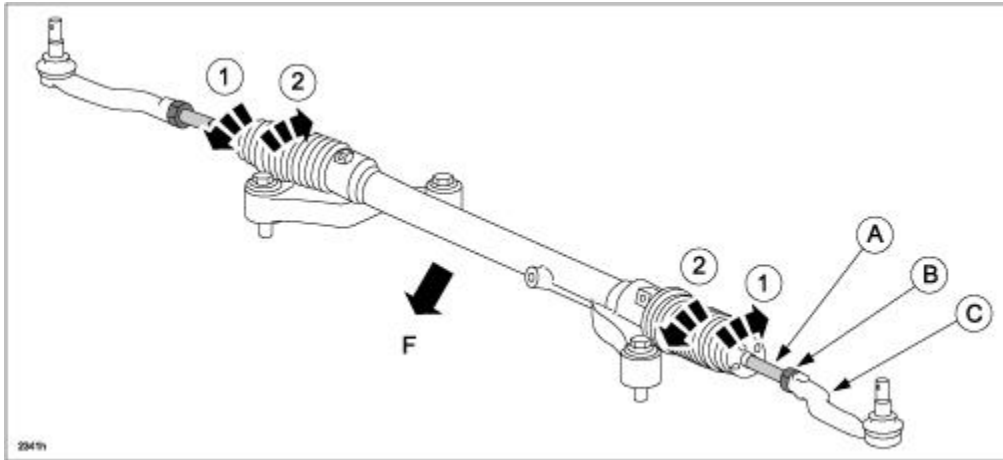

- (Reference) Steering wheel offset and tie-rod rotating angle -

Steering wheel offset to adjust	Tie-rod rotating angle
4 mm (approximately 4°)	150°
5 mm (approximately 5°)	180° (half turn)
6 mm (approximately 6°)	210°
7 mm (approximately 7°)	240°

11. Tighten the lock nut. Refer to MGSS online instructions for the tightening torque.
12. Straighten the boot, then attach the boot clamp.
13. Verify repair.

**CONSUMER NOTICE:** The information and instructions in this bulletin are intended for use by skilled technicians. Mazda technicians utilize the proper tools/equipment and take training to correctly and safely maintain Mazda vehicles. These instructions should not be performed by "do-it-yourselfers." Customers should not assume this bulletin applies to their vehicle or that their vehicle will develop the described concern. To determine if the information applies, customers should contact their nearest authorized Mazda dealership. Mazda North American Operations reserves the right to alter the specifications and contents of this bulletin without obligation or advance notice. All rights reserved. No part of this bulletin may be reproduced in any form or by any means, electronic or mechanical---including photocopying and recording and the use of any kind of information storage and retrieval system ---without permission in writing.

## WARRANTY INFORMATION

### NOTE:

- This warranty information applies only to verified customer complaints on vehicles eligible for warranty repair.
- This repair will be covered under Mazda's Service Adjustment Warranty term (12 months/12,000 miles).
- Additional diagnostic time cannot be claimed for this repair.
- This Service Bulletin cannot be combined with a wheel alignment

Warranty Type	A
Symptom Code	30
Damage Code	9H
Part Number Main Cause	5555-FE-001
Quantity	0
Operation Number / Labor Hours:	XXF11XAX / 0.4 Hrs.

**CONSUMER NOTICE:** The information and instructions in this bulletin are intended for use by skilled technicians. Mazda technicians utilize the proper tools/equipment and take training to correctly and safely maintain Mazda vehicles. These instructions should not be performed by "do-it-yourselfers." Customers should not assume this bulletin applies to their vehicle or that their vehicle will develop the described concern. To determine if the information applies, customers should contact their nearest authorized Mazda dealership. Mazda North American Operations reserves the right to alter the specifications and contents of this bulletin without obligation or advance notice. All rights reserved. No part of this bulletin may be reproduced in any form or by any means, electronic or mechanical---including photocopying and recording and the use of any kind of information storage and retrieval system ---without permission in writing.