

January 14, 2020

Version 1

Product Update: 2017 Accord Hybrid Brake Tandem Motor Cylinder

AFFECTED VEHICLES

Year	Model	Trim	VIN Range
2017	Accord Hybrid	ALL	Check the iN VIN status for eligibility.

BACKGROUND

The brake tandem motor cylinder on certain vehicles may only operate in failsafe mode if saltwater (in areas where road salt is used) enters the brake tandem motor cylinder and corrodes its metal components. The saltwater is able to enter the motor due to small gaps in the motor cover that result from issues in the manufacturing process. If the brake tandem motor cylinder enters into failsafe mode, instrument panel indicators will come on to alert the driver and there will be an increase in brake pedal travel during braking.

NOTE

For this product update, American Honda has identified vehicles located or registered in the following severe road salt damage states as being affected: Alaska, Colorado, Connecticut, Delaware, Illinois, Indiana, Iowa, Maine, Maryland, Massachusetts, Michigan, Minnesota, Montana, Nebraska, New Hampshire, New Jersey, New York, North Dakota, Ohio, Pennsylvania, Rhode Island, South Dakota, Vermont, West Virginia, Wisconsin and Wyoming.

CUSTOMER NOTIFICATION

Owners of affected vehicles will be sent a notification of this campaign.

Do an iN VIN status inquiry to make sure the vehicle is shown as eligible.

Some vehicles affected by this campaign may be in your new or used vehicle inventory. Repair these vehicles before they are sold.

CORRECTIVE ACTION

Replace the brake tandem motor.

PARTS INFORMATION

Part Name	Part Number	Quantity
Brake Tandem Motor	57032-T3Z-A20	1

CUSTOMER INFORMATION: The information in this bulletin is intended for use only by skilled technicians who have the proper tools, equipment, and training to correctly and safely maintain your vehicle. These procedures should not be attempted by "do-it-yourselfers," and you should not assume this bulletin applies to your vehicle, or that your vehicle has the condition described. To determine whether this information applies, contact an authorized Honda automobile dealer.

REQUIRED MATERIALS

Part Name	Part Number	Quantity
Brake Fluid (DOT 3)	08798-9008	2

WARRANTY CLAIM INFORMATION

Operation Number	Description	Flat Rate Time	Defect Code	Symptom Code	Template ID	Failed Part Number
4131AV	Replace the brake tandem motor, and bleed the brake system.	1.7 hr	6TM00	Z6O00	A20001A	57032-T3Z-A20

Skill Level: Repair Technician

REPAIR PROCEDURE

1. Open the hood, and secure it with the hood support rod in the wide-open position.

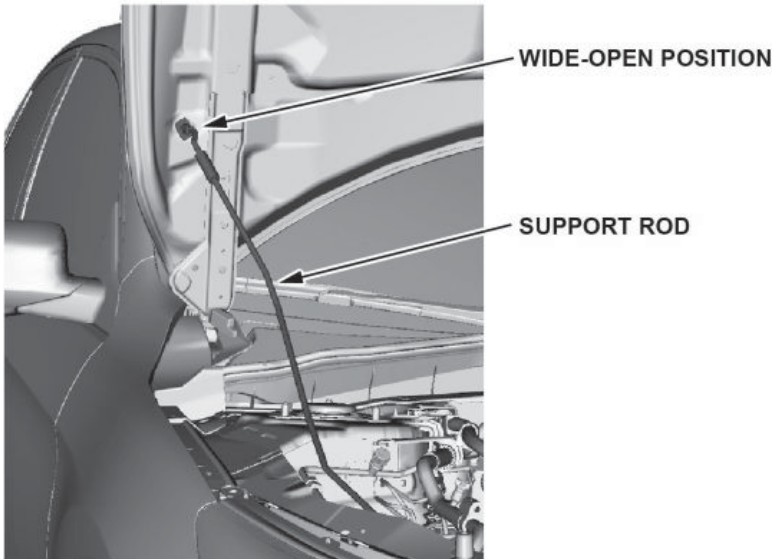

2. Disconnect the 12-volt battery terminals.

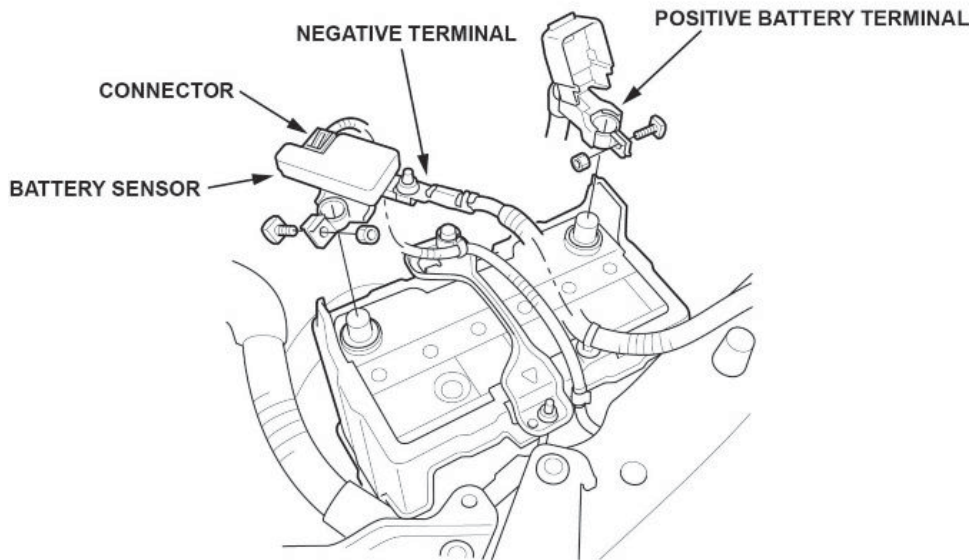

- 2.1. Make sure the ignition is turned to OFF.
- 2.2. Disconnect and isolate the negative cable with the battery sensor from the battery.

NOTES

- Always disconnect the negative side first.
- To protect the connector from damage, do not hold it when removing the negative terminal.
- Do not disconnect the battery sensor from the negative terminal.

- 2.3. Disconnect the positive cable from the battery terminal.

3. Using a syringe, remove the brake fluid from the reservoir tank.

NOTE

Spilled brake fluid may damage painted surfaces. If spilled, wash it off immediately with water.

4. Remove the intake air resonator.

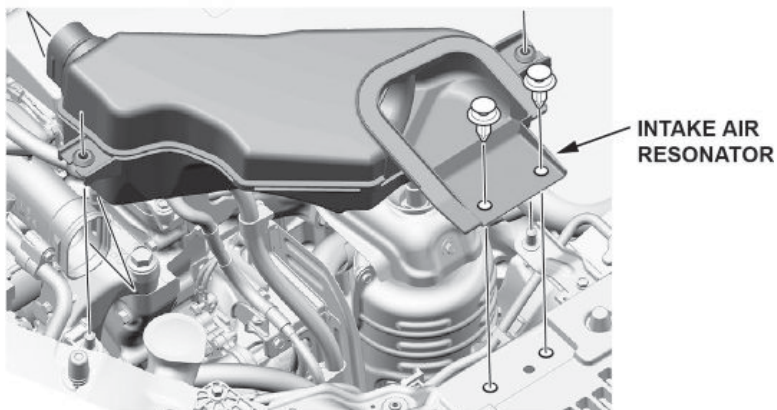

5. Remove the intake air duct.

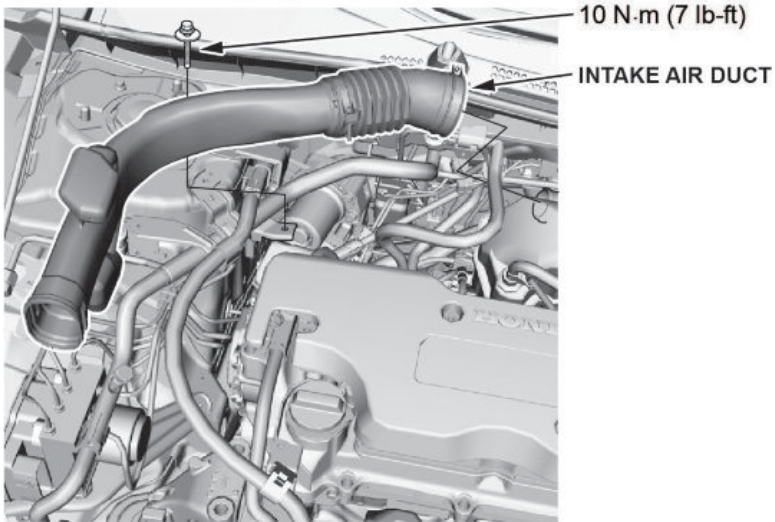

6. Remove the intake air duct bracket.

NOTE

The electric powertrain components are located in this area. The electric powertrain is a high-voltage system. You must be familiar with the electric powertrain system before working on or around it. Make sure you have read the electric powertrain service precautions before doing repairs or service.

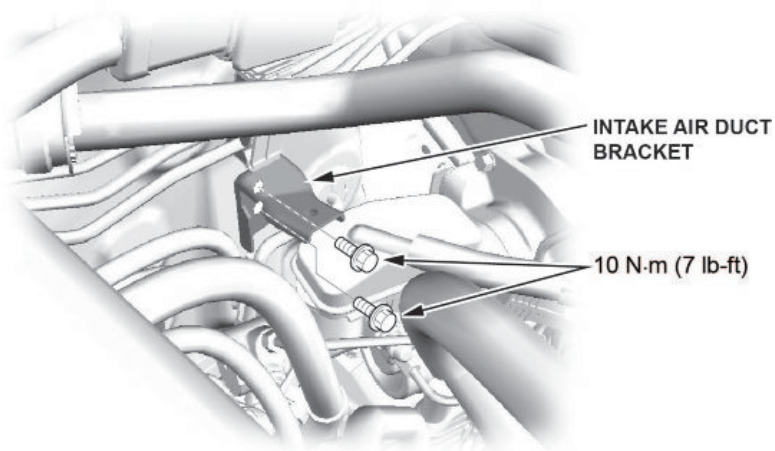

7. Disconnect the suction hose from the subreservoir.

NOTE

Plug the end of the suction hose, and install a cap on the subreservoir to avoid spilling brake fluid.

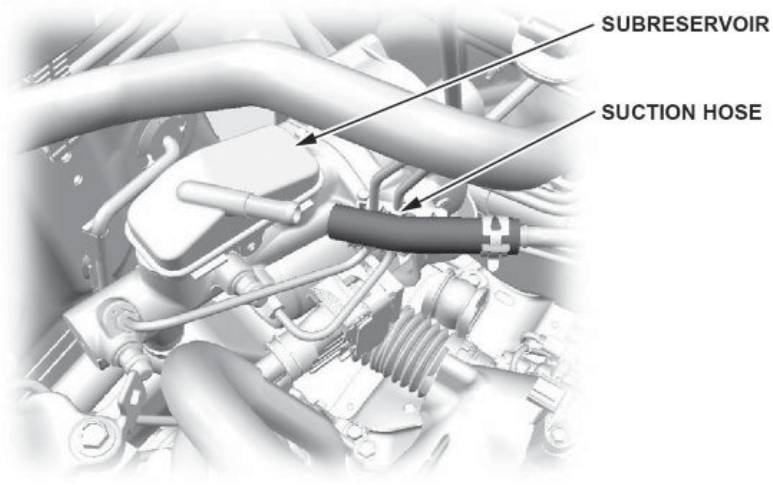

8. Disconnect the brake lines from the tandem motor cylinder.

NOTE

Plug the ends of the brake lines, and install caps on the tandem motor side to avoid spilling brake fluid.

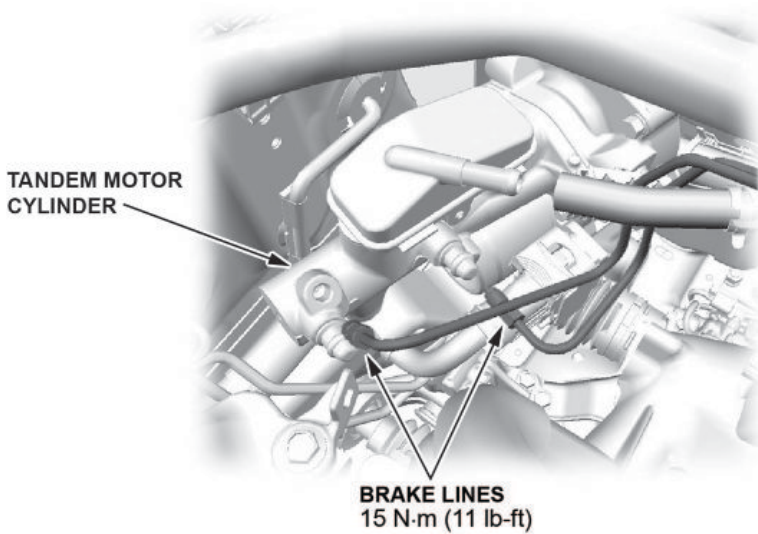

9. Disconnect the connector by pushing the lock and pulling down on the lever.

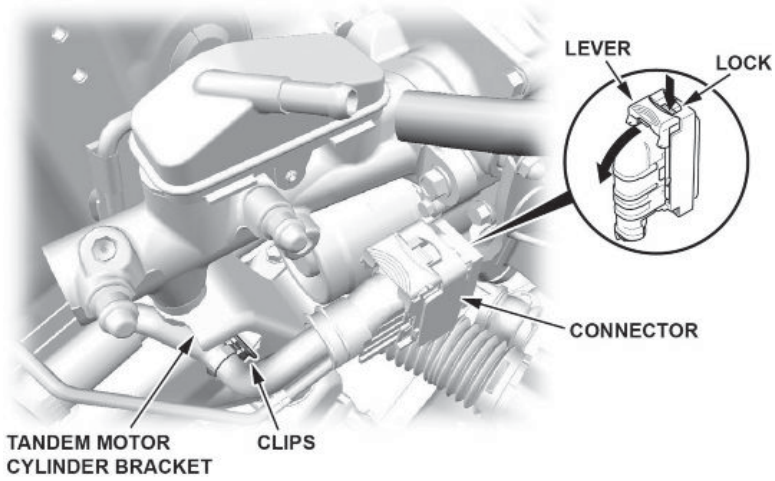

10. Remove the bottom bolt and side nuts from the tandem motor cylinder, and slide the rubber mount forward out of the tandem motor cylinder bracket. Remove the tandem motor cylinder without the bracket.

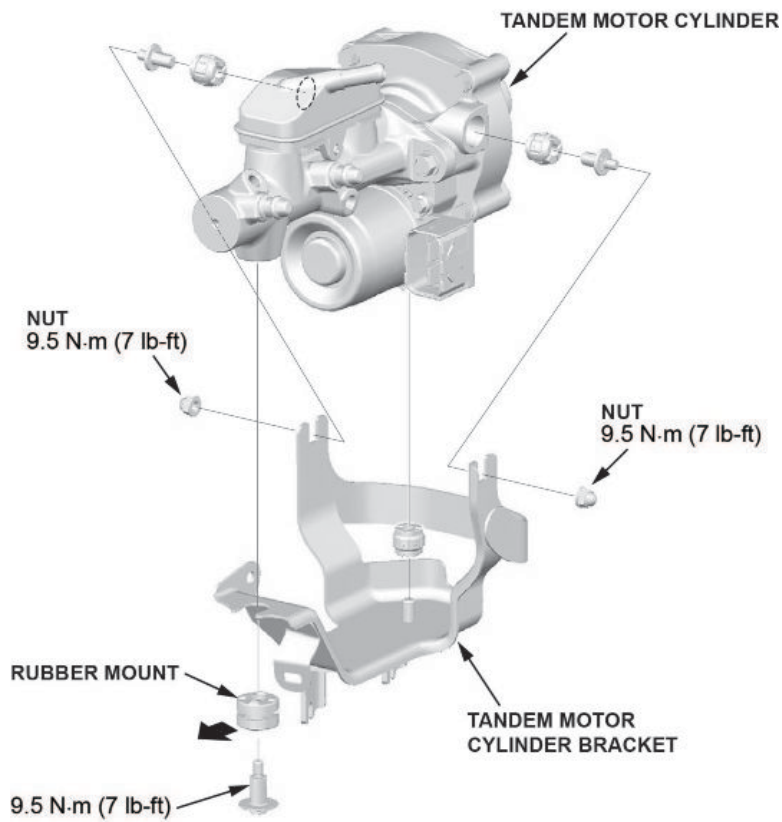

11. Remove the motor and the O-ring from the tandem motor cylinder assembly.
12. Apply brake fluid to the new O-ring, apply the included grease to the motor shaft, and install the new tandem motor.

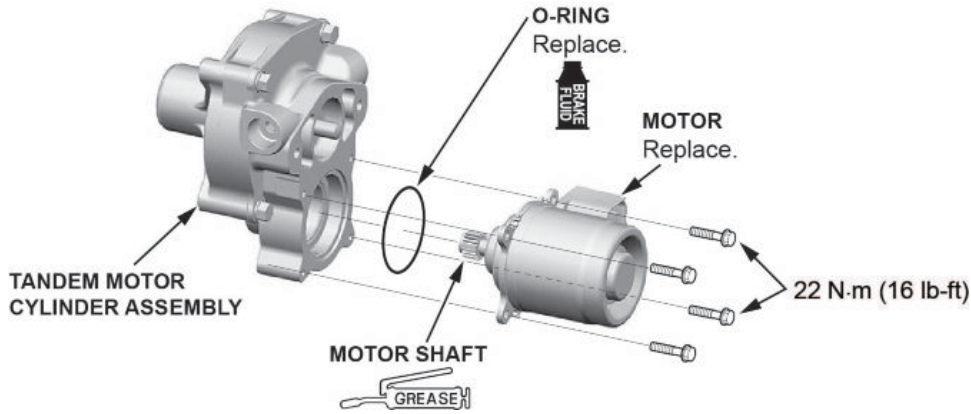

13. Install all removed parts in the reverse order of removal **except** the intake air duct, intake resonator, and the 12-volt battery terminals.
14. Make sure the brake fluid in the reservoir tank is at the MAX (upper) level line.

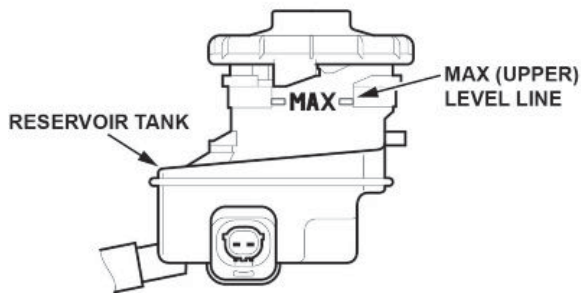

15. Have an assistant sit in the driver's seat, and raise the vehicle on a lift. Start with the front driver's brake caliper.

NOTE

Bleed the calipers as shown. The reservoir must be at the MAX (upper) level mark at the start of the bleeding procedure and checked after bleeding each wheel location. Add fluid as required.

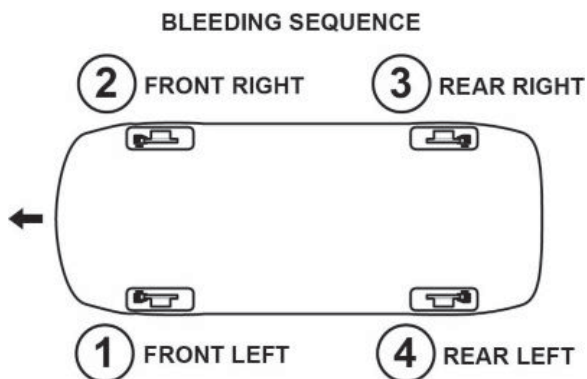

16. Attach a length of clear drain tube to the bleed screw.

FRONT BLEED SCREW

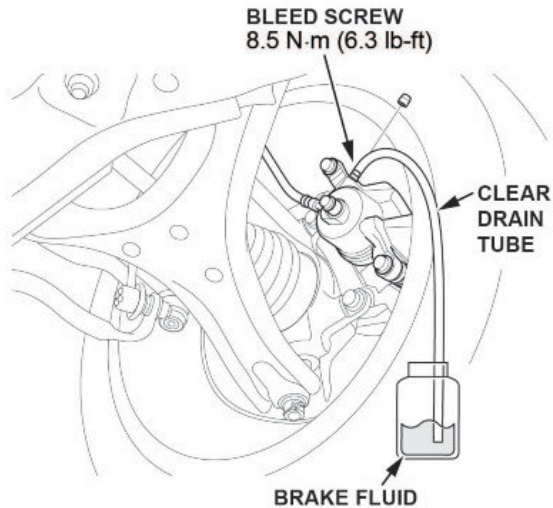

REAR BLEED SCREW

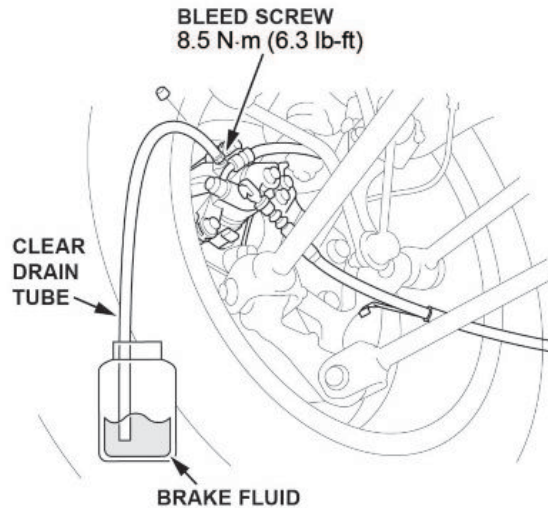

17. Submerge the other end of the drain tube in a clear plastic brake fluid catch bottle.
18. Have an assistant slowly pump the brake pedal several times then apply steady, continuous pressure.
19. Loosen the bleed screw slowly to bleed the fluid into the plastic catch bottle. The brake pedal will travel toward the floor as the fluid is bled from the system.
20. When the brake pedal reaches the floor, have the assistant hold the pedal in that position, then tighten the bleed screw. The brake pedal can now be released.
21. Repeat steps 18 thru 20 until the brake fluid in the clear drain tube appears fresh and there are no air bubbles in the fluid.
22. Repeat steps 16 thru 21 for each brake caliper in the bleeding sequence.
23. After bleeding the four brake calipers, attach a length of clear drain tube to the rear bleed screw of the tandem motor cylinder.

FRONT BLEED SCREW

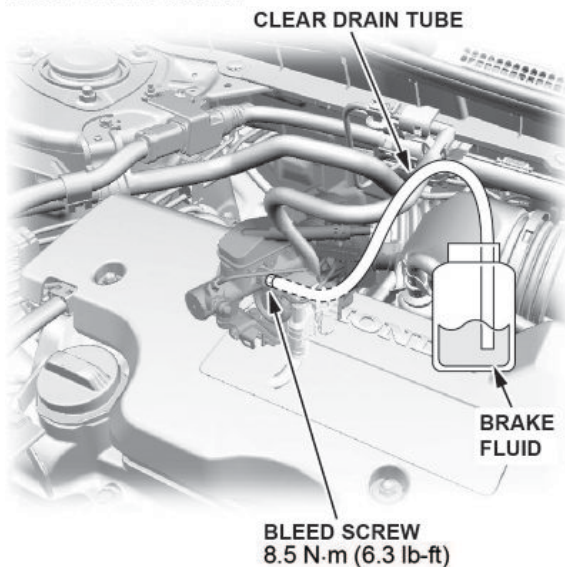

REAR BLEED SCREW

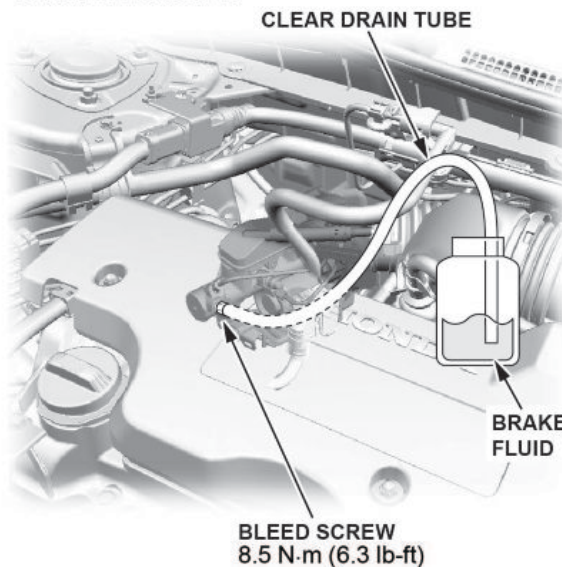

24. Submerge the other end of the drain tube in a clear plastic brake fluid catch bottle.
25. Have an assistant slowly pump the brake pedal several times then apply steady, continuous pressure.

26. Slowly loosen the bleed screw to bleed the fluid into the plastic catch bottle. The brake pedal will travel toward the floor as the fluid is bled from the system.
27. When the brake pedal reaches the floor, have the assistant hold the pedal in that position, then tighten the bleed screw. The brake pedal can now be released.
28. Repeat steps 25 thru 27 until the brake fluid in the clear drain tube appears fresh and there are no air bubbles in the fluid.
29. Repeat steps 23 thru 28 for the front bleed screw of the tandem motor cylinder.
30. Bleed all four calipers once more, repeating steps 15 thru 22 to conduct the bleeding procedure.
31. Install the intake air duct, intake resonator, and the 12-volt battery terminals in the reverse order of removal.
32. Turn the ignition to ON. Check that no DTCs are stored and the BRAKE SYSTEM indicator does not come on.

END