

UPDATE Technical Bulletin



November 28, 2018

51G4 UPDATE – Seam Sealer Application (NVLW)

NOTE:

- Perform this UPDATE on all applicable vehicles within New Vehicle Limited Warranty.
- It is MANDATORY to perform UPDATES on all applicable vehicles in dealer inventory PRIOR TO RETAIL SALE.
- Inform customers that this UPDATE will be available free of charge as long as their vehicle is within the Warranty parameters outlined in this UPDATE.

NOTE:

Required DMS Wording//Text: (line item, customer concern description on repair order):

UPDATE Code 51G4 - Seam Sealer Application (NVLW)

Model(s)	Year	VIN Range	Vehicle-Specific Equipment
Jetta	2019	See Campaign/Action screen in Elsa	See Campaign/Action screen in Elsa

REVISION HISTORY		
Revision	Date	Purpose
1	November 09, 2018	Original publication
2	November 28, 2018	Additional notes added to the work procedure on pages 3 and 13.

Condition

This update has been proactively released to apply seam sealer to prevent water from entering and wetting the driver and or passenger floor board area.

This UPDATE is in effect until removed.

Vehicle must meet all of the following criteria:

- Procedure is valid only for vehicles that show the 51G4 code in Elsa, Campaign/Action Information screen on the day of repair.
- If the vehicle is sold it must be within the NVLW.
- Procedure must be performed within the allotted time frame stated in this UPDATE.
- Procedure must be performed on applicable vehicles in dealer inventory prior to sale.

UPDATE Technical Bulletin



Technical Background

Water leak due to improper application of body seam sealer.

Production Solution

Apply seam sealer at the seam of the plenum chamber and A-pillar as of VIN: BU_KM118788.

Service

Apply seam sealer.

NOTE:

- *Elsa is the only valid inquiry/verification source. Check Elsa on the day this vehicle UPDATE will be performed to verify vehicle eligibility for the UPDATE. Status must show “open”. Attach an Elsa printout showing the “open” status to the repair order.*
- *If this UPDATE appears to have already been performed but the code still shows open in Elsa, contact Warranty before proceeding further. Another dealer may have recently performed this UPDATE but not yet entered a claim for it in the system.*
- *Elsa may also show additional open action(s); if so, inform your customer - this work can be done while the vehicle is in for this UPDATE.*
- *Contact the Warranty Helpline (U.S.) or the Warranty Campaign Specialist (Canada) if you have any questions.*

Applicable Criteria ID (s)	Campaign/Action Status
01	Open

EXAMPLE

Section A – Check for Previous Repair

- Enter the VIN in Elsa and proceed to the “Campaign/Action” screen

TIP

On the date of repair, print this screen and keep a copy with the repair order

- Ensure that the Status is “Open” <arrow 2>
- Note the Applicable Criteria ID <arrow 1> for use in determining the correct work to be done and corresponding parts associated.

Proceed to Section B



NOTE

- Damages resulting from improper repair or failure to follow these work instructions are the dealer's responsibility and are not eligible for reimbursement under this action.
- This procedure must be read in its entirety prior to performing the repair.
- Due to variations in vehicle equipment and options, the steps/illustrations in this work procedure may not identically match all affected vehicles.
- Diagnosis and repair of pre-existing conditions in the vehicle are not covered under this action.
- When working during extreme temperatures, it is recommended that the vehicle be allowed to acclimate inside the shop to avoid temperature-related component damage/breakage.

Section B – Repair Procedure

NOTE

If moisture is found in the interior of the vehicle, diagnosis and repair as needed following normal warranty policy. Any additional repair work must be submitted on a separate warranty claim.

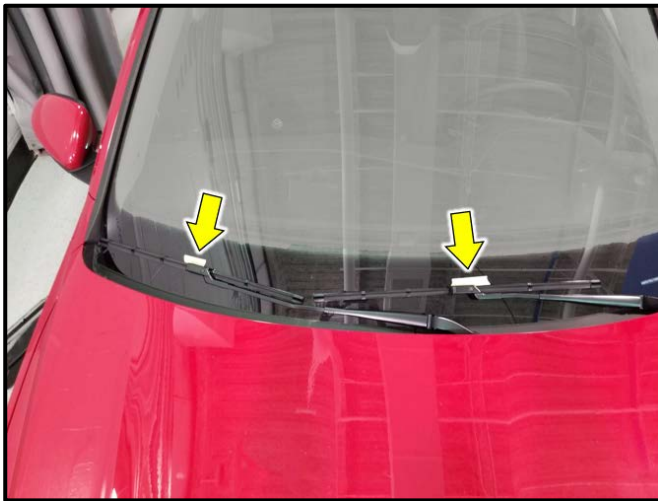

Mark wiper park position.

- Mark the wiper park position with tape <arrows> or other means.

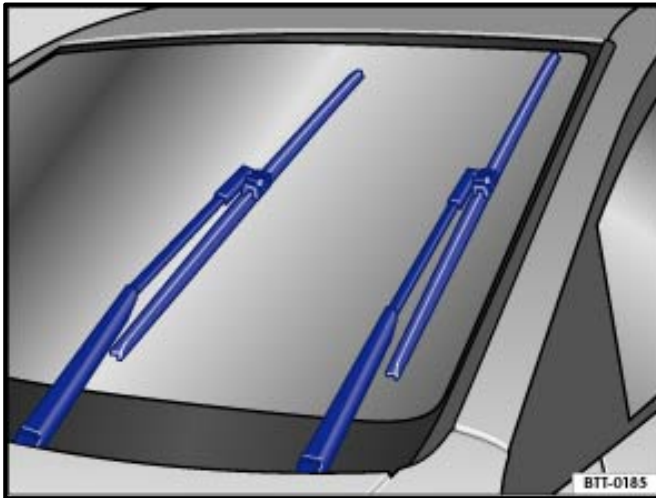

Put wipers in service position.

- The hood must be closed.
- Briefly turn the ignition on and then off again.
- Turn the windshield wiper lever in the “one-touch wiping position” within 10 seconds.

NOTE

Wipers must be in service position in order to remove wiper linkage.

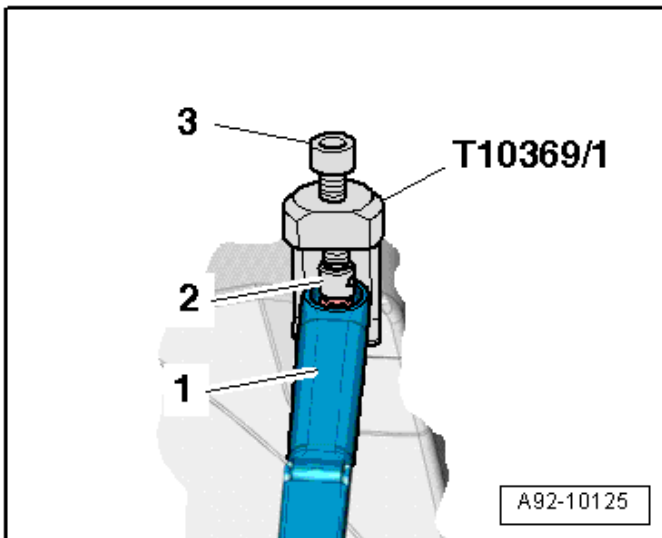

Remove left and right wiper arms.

- Pry off cap with a small screwdriver.
- Remove nut.
- Position the -T10369/1- on the windshield wiper arm <1> as shown.
- Position the thrust piece <2> on the wiper arm shaft.
- Turn the bolt <3> clockwise until the windshield wiper arm <1> is removed from the wiper arm shaft.
- Remove the nut completely and remove the windshield wiper arm <1>.

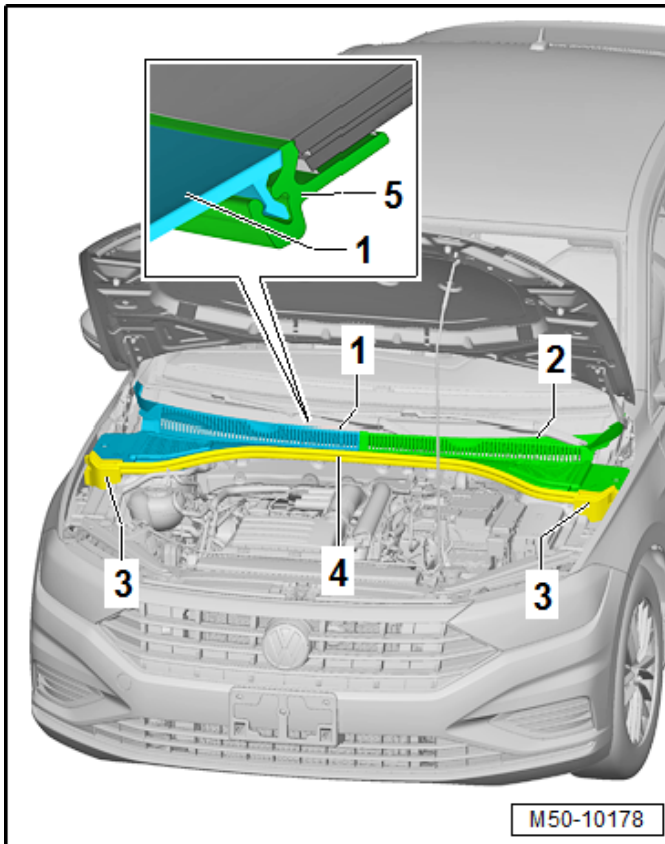

Remove plenum chamber covers <1 and 2>:

- Remove the seal <4> forward from the plenum chamber covers <1 and 2>.
- Remove the left and right foam piece <3> from the plenum chamber covers <1 and 2>.
- Remove clip for washer hose from left plenum chamber cover.
- Remove the left plenum chamber cover <2> upward from the retainer <5>.
- Remove the right plenum chamber cover <1> upward from the retainer <5>.

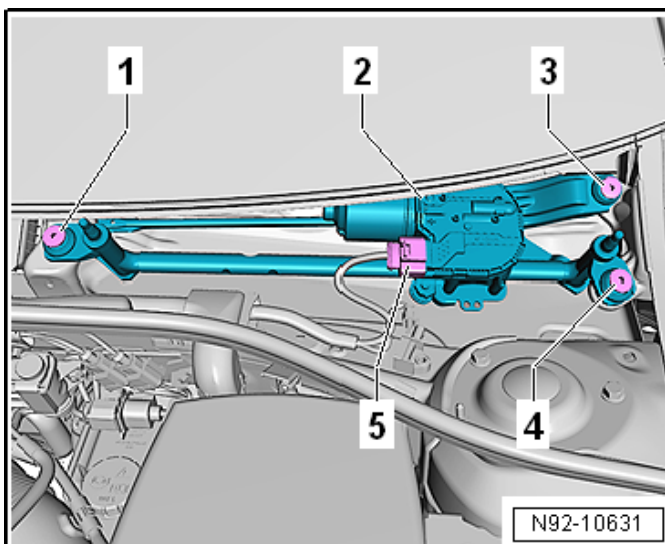

Remove wiper linkage and motor.

- Disconnect connector <5>.
- Remove bolts <1, 3 and 4>.
- Remove the wiper frame <2> with linkage and wiper motor from the plenum chamber.

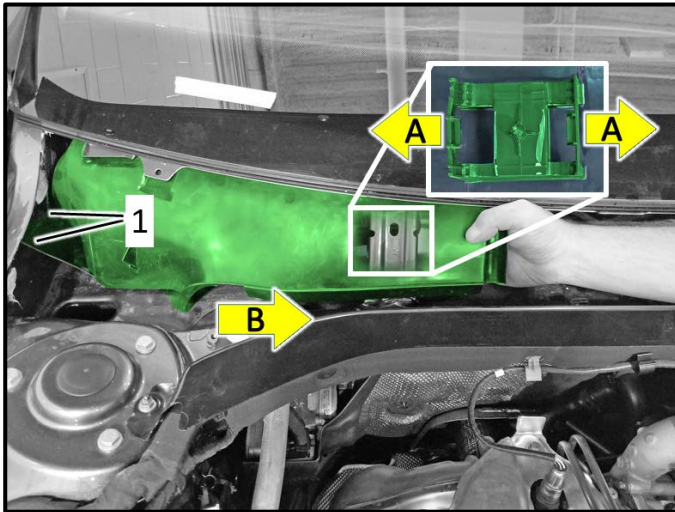

Remove HVAC fresh air intake water deflector.

- Reach under the deflector and release locking tabs in direction of <arrows A>.
- Pull deflector up slightly from the plenum chamber and remove off of mounts <1> in direction of <arrow B>.

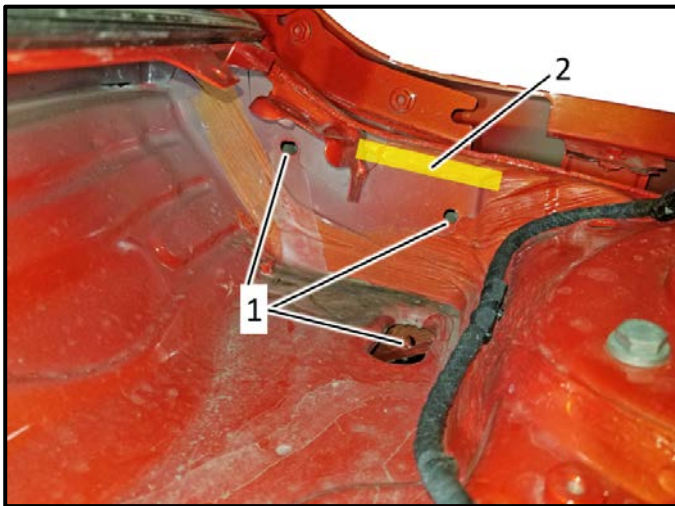

Apply seam sealer driver side.

- Use a gloved finger or a small brush to apply the seam sealer.
- Ensure area is dry.
- Completely cover holes <1> with sealer.

! NOTE

Do not cover the large plenum chamber drain.

- Completely cover exposed seams in the shaded area <2>.

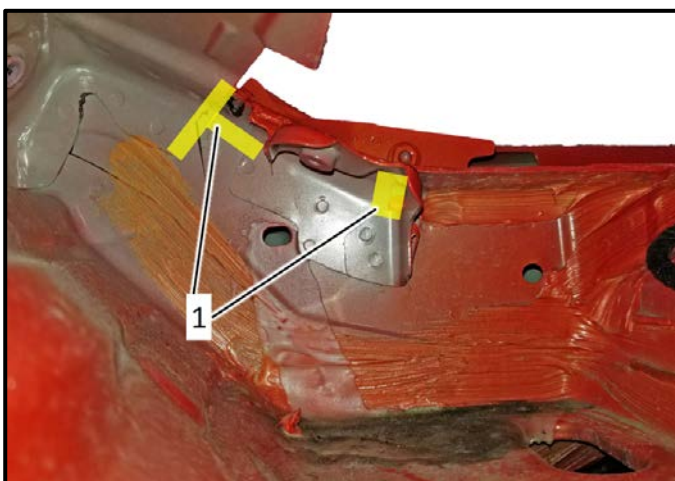

Apply seam sealer driver side (cont.)

- Ensure area is dry.
- Completely cover exposed seams in the shaded areas <1>.

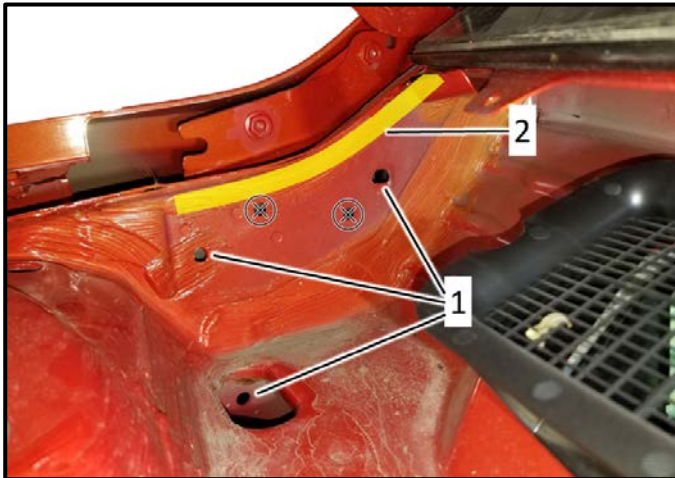

Apply seam sealer passenger side.

- Use a gloved finger or a small brush to apply the seam sealer.
- Ensure area is dry.
- Completely cover holes <1> with sealer.

! NOTE	
	<ul style="list-style-type: none"> • Do not cover the large plenum chamber drain. • Do not cover the holes for the water deflector.

- Completely cover exposed seams in the shaded area <2>.

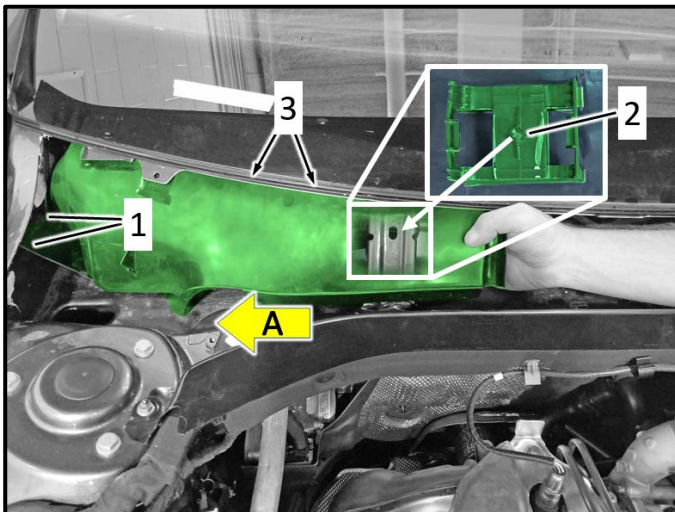

Install HVAC fresh air intake water deflector.

- Line up mounts <1> and install deflector in direction of <arrow A>.
- Line up pin <2> with the hole on the plenum chamber bracket and clip deflector in place.
- The deflector must be installed underneath the plenum chamber cover retainer <3>.

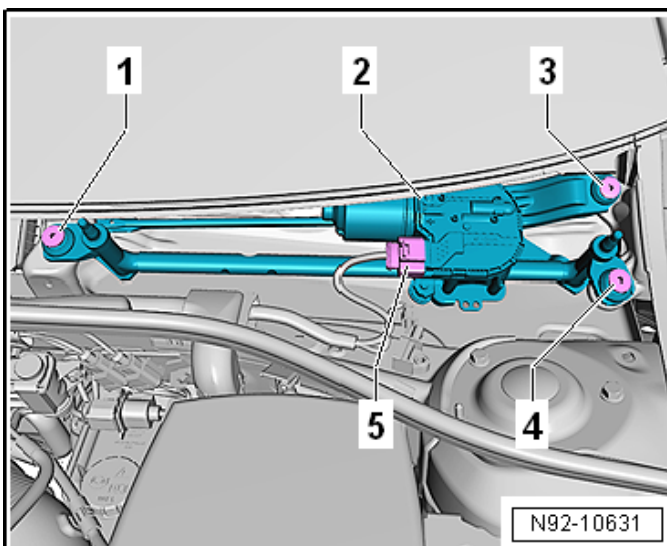

Install wiper linkage and motor.

- Hand tighten bolts in sequence <4 - 3 - 1>.
- Torque bolts in sequence <4 - 3 - 1> to 8 Nm.
- Connect connector <5>.

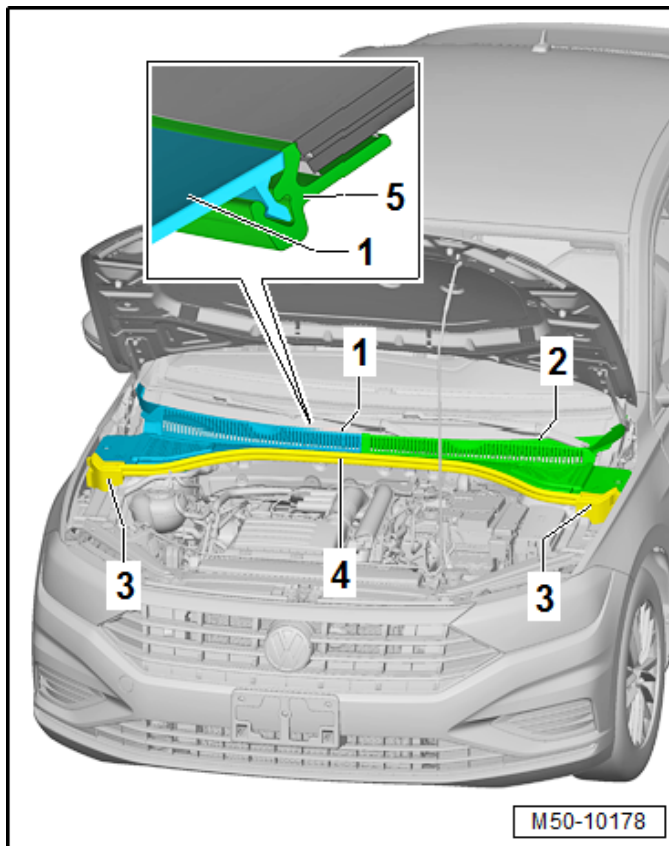

Install plenum chamber covers.

- Spray the retainer <5> with soapy water so that the plenum chamber covers <1 and 2> can be clipped in more easily.
- Place the plenum chamber cover <1> on the retainer <5>. Starting at the outside, gently push it into the retainer <5>.
- Place the plenum chamber cover <2> on the retainer <5>. Starting at the outside, gently push it into the retainer <5>.
- Install the seal <4>.
- Install the left and right foam piece <3>.
- Install clip for washer hose onto left plenum chamber cover.

! NOTE

Striking the plenum chamber cover into the windshield retainer may cause the windshield to crack. Damage to the windshield or plenum chamber covers will not be covered under this action.

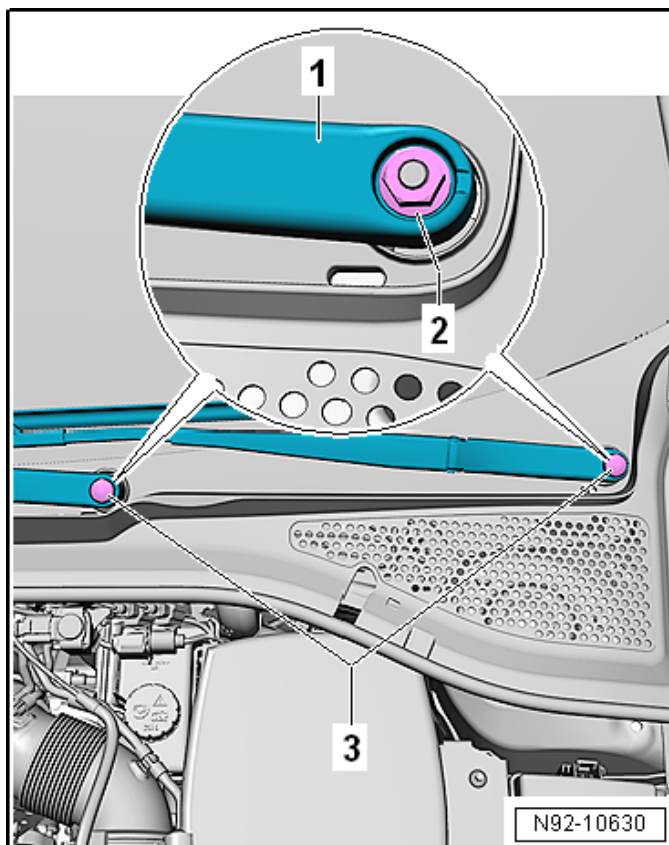

Take wipers out of service position.

- Close the hood.
- Turn ignition on.
- Operate wipers and then turn wipers to the off position.
- Turn ignition off.

Install left and right wiper arms.

- Open the hood.
- Reference previously made marks and install wiper arms on wiper linkage studs.
- Install nuts <2> and torque to 20 Nm.
- Install caps <1>.
- Close the hood.
- Turn ignition on and verify wiper operation.



- After seam sealer is applied, the vehicle cannot be washed or be in the rain for 24 hours to allow for proper curing of the seam sealer.

 **NOTE**

Temperature does not affect curing time.

UPDATE Technical Bulletin



Warranty

Claim Entry Procedure	Enter your claim immediately upon completion of the UPDATE. Claims will only be paid for vehicles that show this UPDATE code open in Elsa on the day of repair. To help ensure prompt and proper payment, attach the screen print to the repair order.
Claim Help	<u>U.S. dealers</u> - Contact the Warranty Helpline toll-free at 1-866-306-8447 for help with claim entry. <u>Canadian dealers</u> - Contact your Warranty Campaign Specialist. For contact information, please proceed to "ServiceNet – Warranty/Contact Information/Campaigns – "Warranty Campaign Specialist."
Required Customer Notification	Ensure customers are aware of all work performed on the vehicle by recording the information on the repair order. Attach a copy of the <i>Vehicle UPDATE Fact Sheet</i> to the customer's copy of the repair order and take the time to explain this UPDATE to your customer.

UPDATE Technical Bulletin



Required Parts

Part Description	Part No:	Quantity
Seam Sealer (grey)	D 476.KD1.M2	One canister will repair approxiamtely 12 cars.
-OR- (either part number may be used)		
Seam Sealer (black)	D 476.KD2.M2	
-OR-		
Part Description	3M Part No:	Quantity
3M Seam Sealer (locally sourced)	08369*	One container will repair approxiamtely 12 cars. *(If 3M seam sealer is used, a special applicator gun is not required. Place a small cut in the package and reseal using a resealable bag)
	-OR-	
	08370*	
	-OR-	
	08374	

Required Tools

	<p>Puller - Wiper Arm Kit - Puller 1 -T10369/1-</p>		<p>Torque Wrench 5-50Nm -VAG1331- (or equivalent)</p>
---	---	--	---

Additional Information

All part and service references provided in this Technical Bulletin are subject to change and/or removal. Always check Elsa for the most current version of this document.

UPDATE Technical Bulletin



UPDATE FACT SHEET – UPDATE Code 51G4

Dear Volkswagen Customer,

Today we performed Volkswagen UPDATE - Code 51G4 - Seam Sealer Application on your vehicle. This UPDATE will prevent a potential water leak, and was performed for you free of charge.

Volkswagen periodically makes updates like this available in order to ensure our customer's continued satisfaction with the quality of their Volkswagen vehicles.

We at Volkswagen are committed to providing our customers with reliable, quality products that are a pleasure to drive and own. If you should ever have any questions or vehicle concerns, your authorized Volkswagen dealer will be pleased to assist you.

Thank you for driving a Volkswagen!