

Type: Satisfaction Campaign

Year: 2019

System: Brakes (50)

Sequence: 01

First Release Rev: 0.1

**Title: Brake Line Parts Update**

**Applicability:** MY20 Revero GT Demos

**Market Region:** All

**PRIORITY:** Vehicles on list

**PURPOSE:**

In order to bring the Revero GT into the best performance Karma Automotive is replacing components on the vehicles in current service. This is a guide to replace to four (4) Brake Lines as indicated below (fig. 1) in this bulletin.

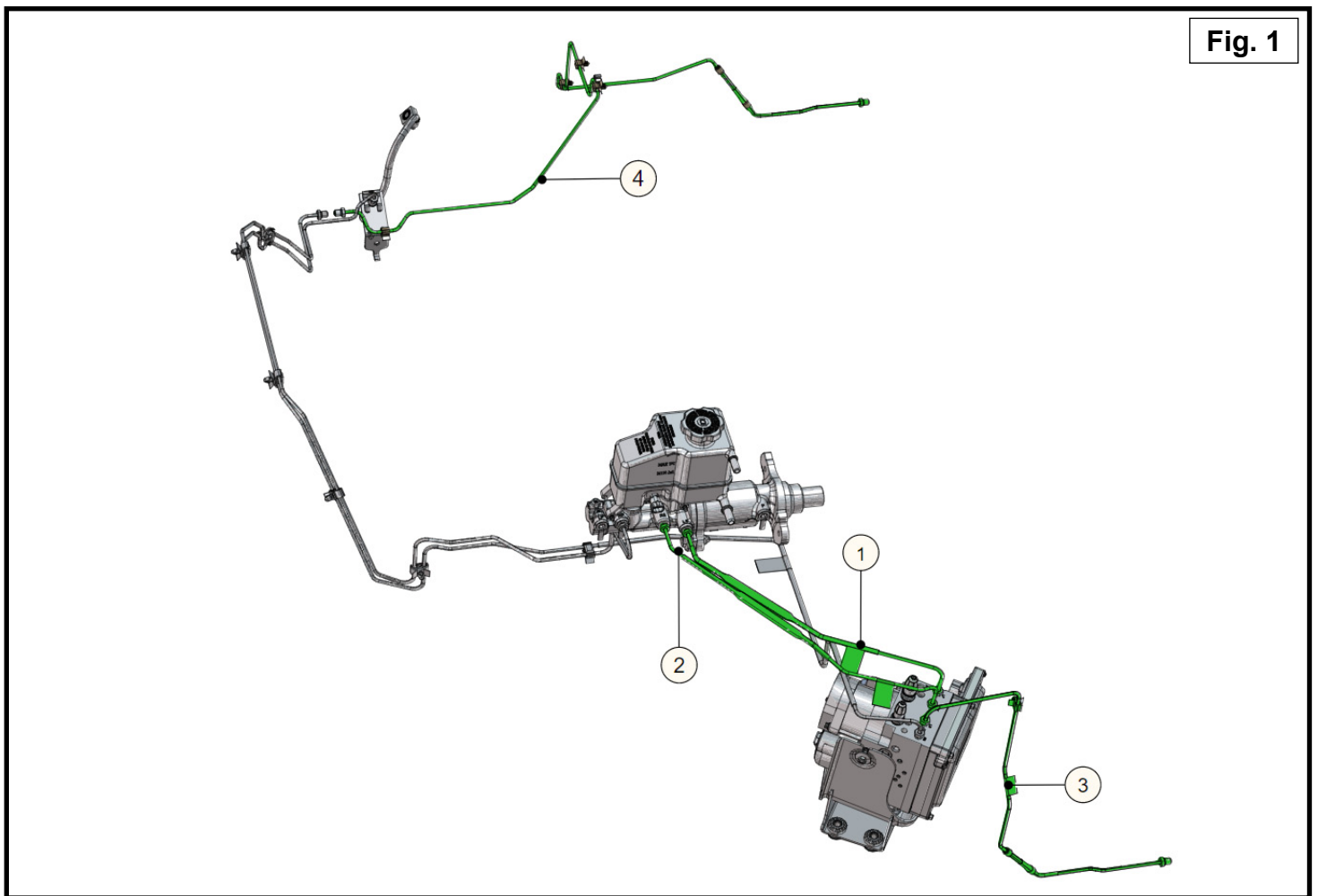

**Fig. 1**

1	C131125003500	Brake line Assembly- MC to EBCM Front LH
2	C131125003600	Brake line Assembly- MC to EBCM Front RH
3	C131125001901	Assembly – Brake Line Mid Rear LH
4	C131125600202	Assembly – Brake Line Mid RH R

Karma Automotive Bulletins and service documents are intended for use by experienced and trained Technicians. If you lack the skills, tools, equipment and a suitable workshop for any procedure described in this document, we suggest you leave such repairs to a Karma retailer and service provider. See your service provider for advice on whether your vehicle may benefit from the information contained within this document. The information contained in the Karma Bulletin is accurate at the date of publication. However, Karma Automotive regularly updates technical information. Please check with your Karma Automotive Retailer and Karma Automotive service provider that the bulletin you intend to use contains the latest available information.

Type: Satisfaction Campaign

Year: 2019

System: Brakes (50)

Sequence: 01

First Release Rev: 0.1

**Title: Brake Line Parts Update**

**Applicability:** MY20 Revero GT Demos

**Market Region:** All

Only the affect vehicle below are subject to this update.

50GK43SB8LA000021	50GK43SB0LA000028
50GK43SB1LA000023	50GK43SB2LA000029
50GK43SB3LA000024	50GK43SB4LA000033
50GK43SB5LA000025	50GK43SB6LA000034
50GK43SB7LA000026	

**Procedure Overview:**

1. Create a TSS case for the affect VIN presented for this operation
2. Disconnect 12V ,Rack and raise the vehicle. Remove all four wheels (220nm fastening torque )
3. Remove the front wheel well liners
4. Remove the Rocker Panel (LH and RH) covers
5. Be prepared to catch and clean up brake fluid as you will experience some spillage
6. Unfasten PTC (HV Fluid heater) ground, Disconnect low voltage connection
7. Loosen the EBCM Bracket, any other component to ease access to the lines on the EBCM and Master cylinder
7. Loosen and remove the lines from the master cylinder to the EBCM (items #1 and #2 below)
8. Loosen and remove line #3 (list below) from EBCM and the in-line connection under the rocker cover as shown in image on first page.
9. Reconnect all the lines with the supplied parts for this (LH) side of the vehicle.
10. Remove indicated line #4 (list below) from the unions and replace with the appropriate supplied part.
11. Reinstall lines and ensure all fasteners are torqued to specification, Check for leaks.
- 12.Reinstall PTC and all PTC connections
- 13.Perform the Karma Sync Brake Bleed Procedure
12. Reassemble the vehicle, and road test.

1	C131125003500	Brake line Assembly- MC to EBCM Front LH
2	C131125003600	Brake line Assembly- MC to EBCM Front RH
3	C131125001901	Assembly – Brake Line Mid Rear LH
4	C131125600202	Assembly – Brake Line Mid RH R

Karma Automotive Bulletins and service documents are intended for use by experienced and trained Technicians. If you lack the skills, tools, equipment and a suitable workshop for any procedure described in this document, we suggest you leave such repairs to a Karma retailer and service provider. See your service provider for advice on whether your vehicle may benefit from the information contained within this document. The information contained in the Karma Bulletin is accurate at the date of publication. However, Karma Automotive regularly updates technical information. Please check with your Karma Automotive Retailer and Karma Automotive service provider that the bulletin you intend to use contains the latest available information.

**Title: Brake Line Parts Update**

**Applicability:** MY20 Revero GT Demos

**Market Region:** All

1. Rack the Vehicle, Disconnect the 12V harness (Fig 2.) and remove all four wheels, Remove the left front (Fig 3) and right front wheel well liners. there are 12 push pins on each.

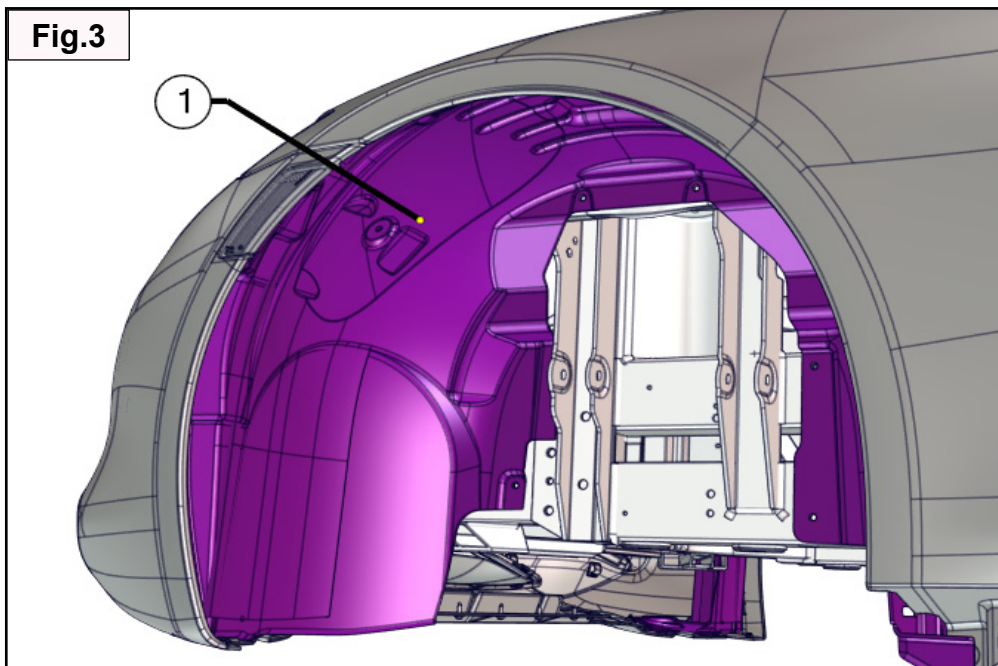
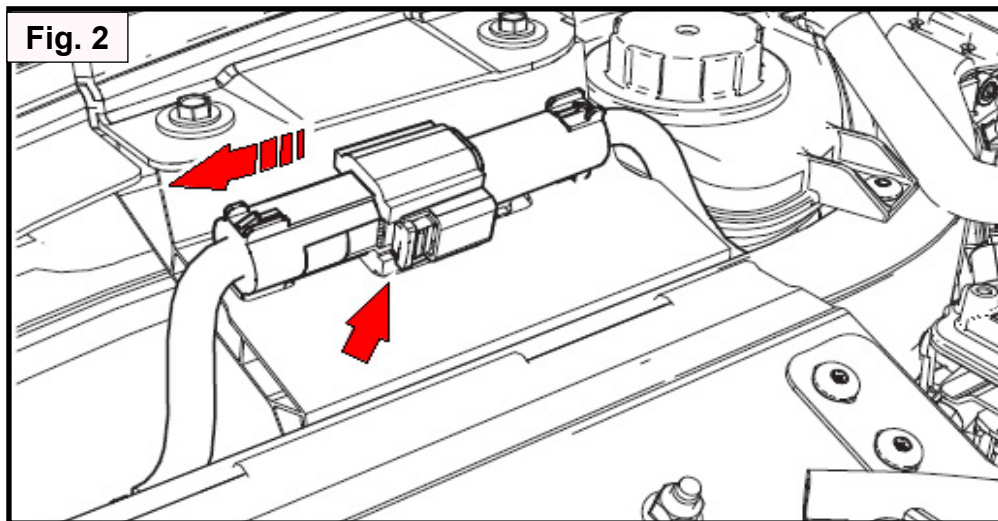

Karma Automotive Bulletins and service documents are intended for use by experienced and trained Technicians. If you lack the skills, tools, equipment and a suitable workshop for any procedure described in this document, we suggest you leave such repairs to a Karma retailer and service provider. See your service provider for advice on whether your vehicle may benefit from the information contained within this document. The information contained in the Karma Bulletin is accurate at the date of publication. However, Karma Automotive regularly updates technical information. Please check with your Karma Automotive Retailer and Karma Automotive service provider that the bulletin you intend to use contains the latest available information.

Type: Satisfaction Campaign

Year: 2019

System: Brakes (50)

Sequence: 01

First Release Rev: 0.1

**Title: Brake Line Parts Update**

**Applicability:** MY20 Revero GT Demos

**Market Region:** All

2. Remove the Rocker panel as seen in (Fig 4. and Fig. 5) The Rocker is held in by nine (9) push clips.

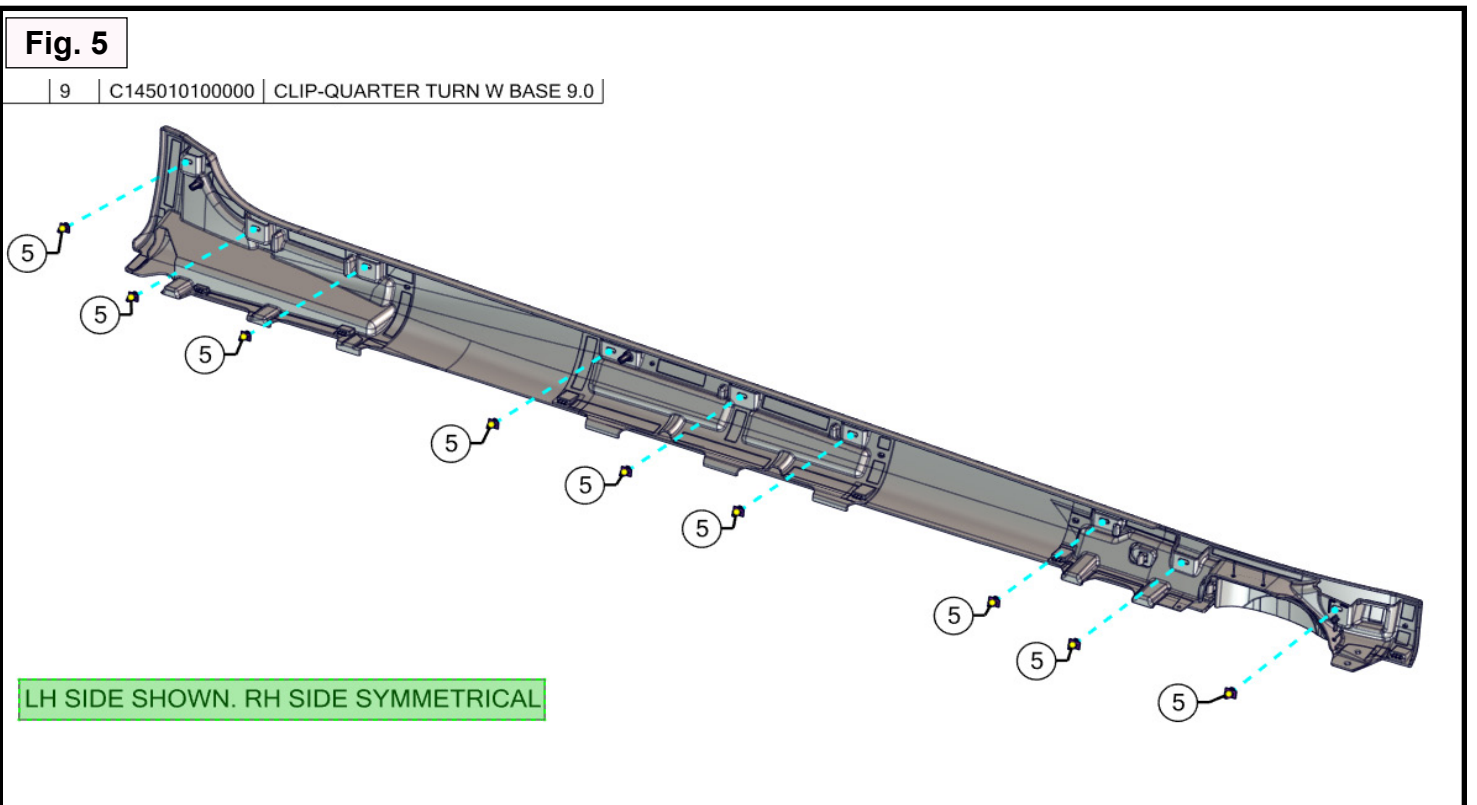
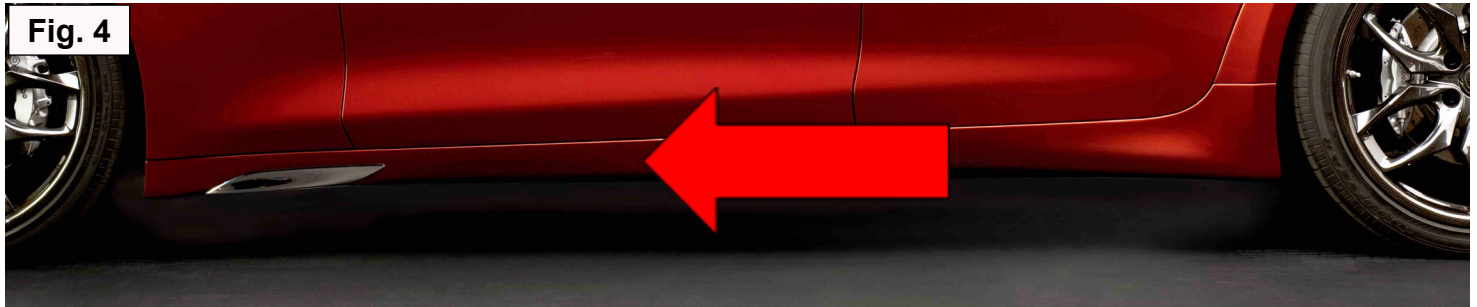

Karma Automotive Bulletins and service documents are intended for use by experienced and trained Technicians. If you lack the skills, tools, equipment and a suitable workshop for any procedure described in this document, we suggest you leave such repairs to a Karma retailer and service provider. See your service provider for advice on whether your vehicle may benefit from the information contained within this document. The information contained in the Karma Bulletin is accurate at the date of publication. However, Karma Automotive regularly updates technical information. Please check with your Karma Automotive Retailer and Karma Automotive service provider that the bulletin you intend to use contains the latest available information.

**Title: Brake Line Parts Update**

**Applicability:** MY20 Revero GT Demos

**Market Region:** All

3. Unfasten PTC ground (torque 7 +/- 1 Nm) (fig. 6). Disconnect low voltage connection. Remove bolt to PTC (T40) Remove Nut from PTC heater (13mm nut), this is to move the assembly to clear space for brake line removal and installation (fig.7).

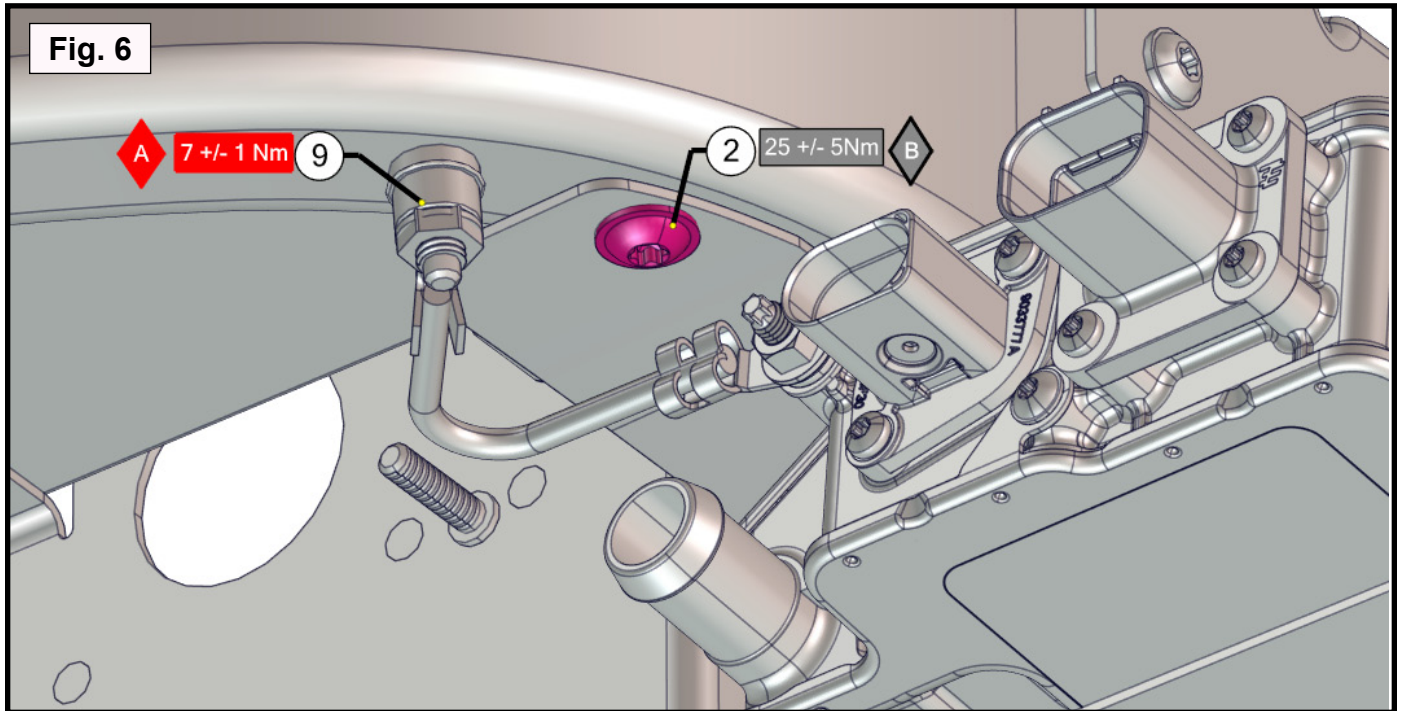

Karma Automotive Bulletins and service documents are intended for use by experienced and trained Technicians. If you lack the skills, tools, equipment and a suitable workshop for any procedure described in this document, we suggest you leave such repairs to a Karma retailer and service provider. See your service provider for advice on whether your vehicle may benefit from the information contained within this document. The information contained in the Karma Bulletin is accurate at the date of publication. However, Karma Automotive regularly updates technical information. Please check with your Karma Automotive Retailer and Karma Automotive service provider that the bulletin you intend to use contains the latest available information.

Type: Satisfaction Campaign

Year: 2019

System: Brakes (50)

Sequence: 01

First Release Rev: 0.1

**Title: Brake Line Parts Update**

**Applicability:** MY20 Revero GT Demos

**Market Region:** All

3. Loosen the EBCM Bracket (fig 8.) to allow further room to unbolt the brake lines. Remove tube nut (13mm) from master cylinder (fig. 9). Plug parts or catch fluid use Take precaution as fluid will lescape. Lines 1- (Brake Line Assembly - MC to EBCM Front LH shown removed) and 2 (Brake Line Assembly - MC to EBCM Front RH C131125003600 in place by red line). For both EBCM and Master cylinder primary lines the fastening torque is 22 Nm +/- 1nm. (Fig 3) Manuever parts out of the wheel well and replace using same path as removal to install

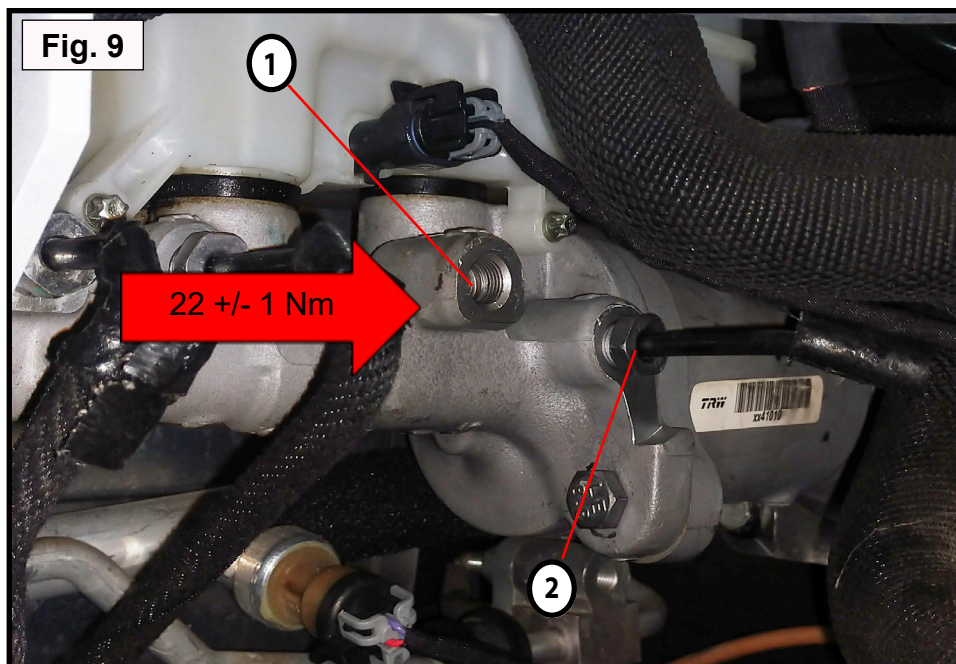
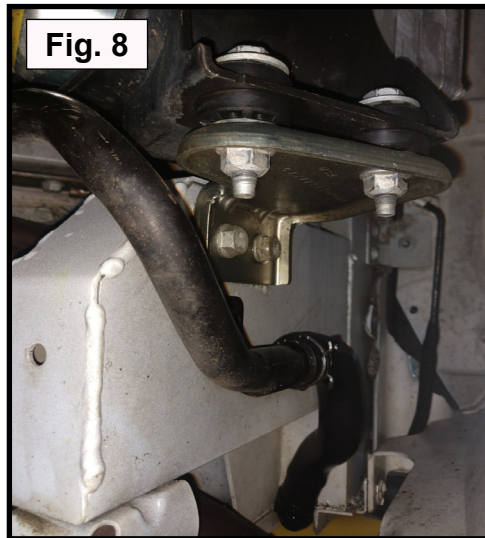

Karma Automotive Bulletins and service documents are intended for use by experienced and trained Technicians. If you lack the skills, tools, equipment and a suitable workshop for any procedure described in this document, we suggest you leave such repairs to a Karma retailer and service provider. See your service provider for advice on whether your vehicle may benefit from the information contained within this document. The information contained in the Karma Bulletin is accurate at the date of publication. However, Karma Automotive regularly updates technical information. Please check with your Karma Automotive Retailer and Karma Automotive service provider that the bulletin you intend to use contains the latest available information.

Type: Satisfaction Campaign

Year: 2019

System: Brakes (50)

Sequence: 01

First Release Rev: 0.1

**Title: Brake Line Parts Update**

**Applicability:** MY20 Revero GT Demos

**Market Region:** All

4. Remove C131125001901(#3 in Fig. 10) Assembly - Brake Line Mid Rear LH remove tube nut (13mm) from EBCM (torque is 22 Nm +/- 1nm). Take precaution as fluid will leak. Plug parts or catch fluid. Remove tube nut (13mm) from union behind rocker take precaution as fluid will leak. Plug parts or catch fluid

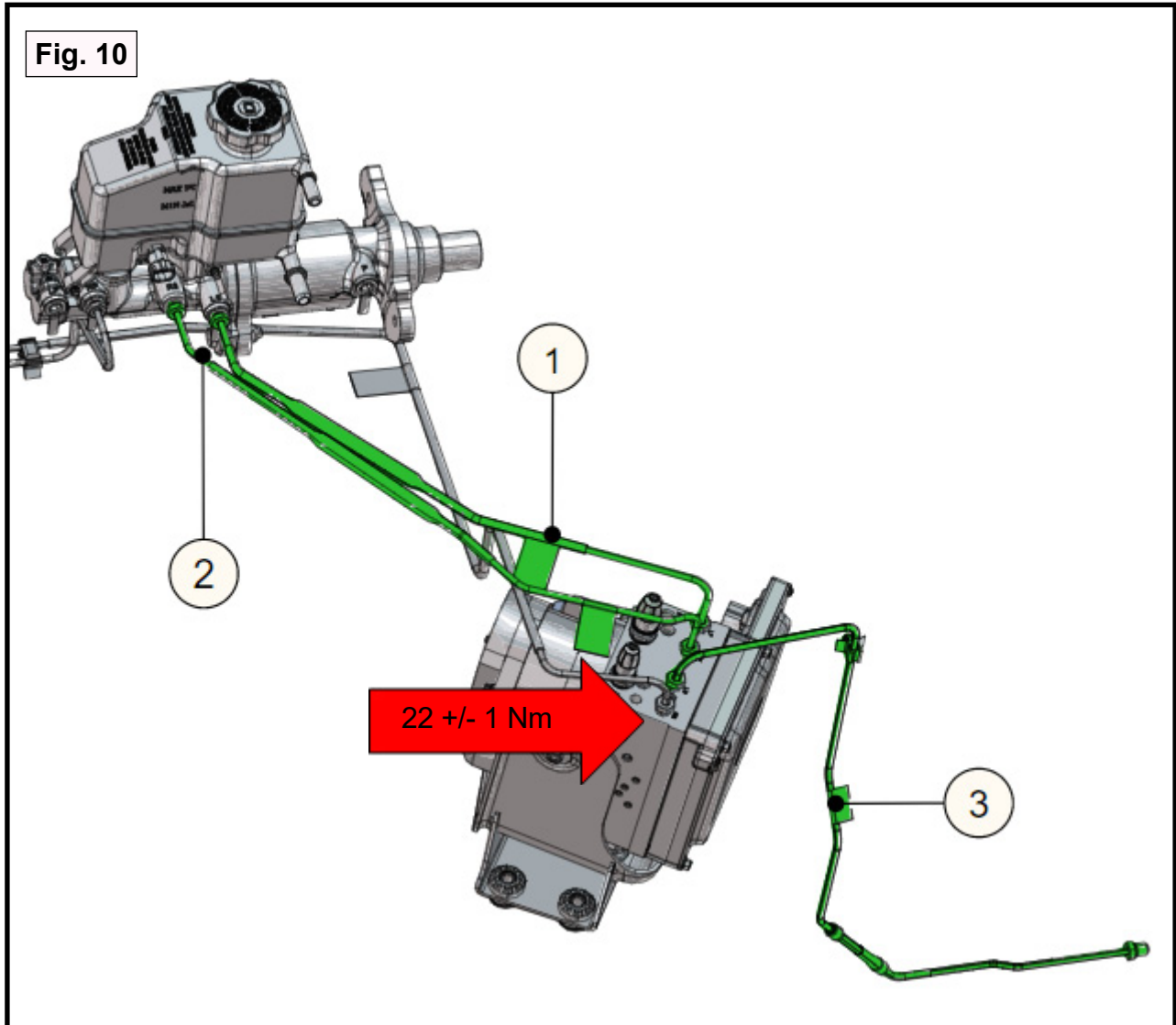

Karma Automotive Bulletins and service documents are intended for use by experienced and trained Technicians. If you lack the skills, tools, equipment and a suitable workshop for any procedure described in this document, we suggest you leave such repairs to a Karma retailer and service provider. See your service provider for advice on whether your vehicle may benefit from the information contained within this document. The information contained in the Karma Bulletin is accurate at the date of publication. However, Karma Automotive regularly updates technical information. Please check with your Karma Automotive Retailer and Karma Automotive service provider that the bulletin you intend to use contains the latest available information.

Type: Satisfaction Campaign

Year: 2019

System: Brakes (50)

Sequence: 01

First Release Rev: 0.1

**Title: Brake Line Parts Update****Applicability:** MY20 Revero GT Demos**Market Region:** All

5. Continuing Remove tube nut (13mm) from union behind rocker take precaution as fluid will leak. Plug parts or catch fluid. (Fig. 11a and Fig. 11b) (Torque 17 +/- Nm). Manuever part out of the wheel well and replace using same path as removal to install.

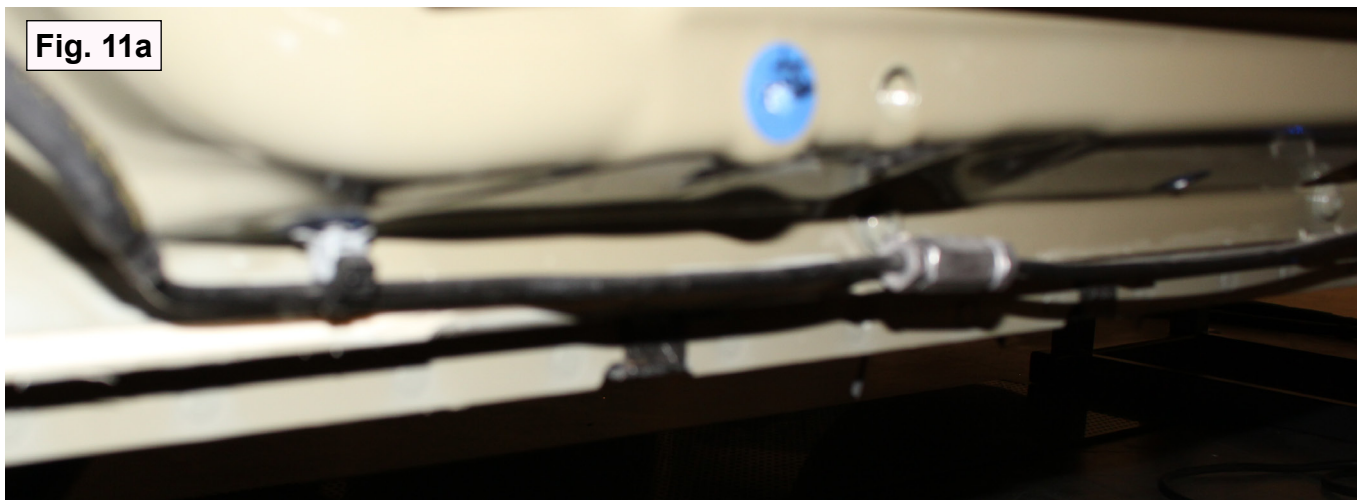

Karma Automotive Bulletins and service documents are intended for use by experienced and trained Technicians. If you lack the skills, tools, equipment and a suitable workshop for any procedure described in this document, we suggest you leave such repairs to a Karma retailer and service provider. See your service provider for advice on whether your vehicle may benefit from the information contained within this document. The information contained in the Karma Bulletin is accurate at the date of publication. However, Karma Automotive regularly updates technical information. Please check with your Karma Automotive Retailer and Karma Automotive service provider that the bulletin you intend to use contains the latest available information.

Type: Satisfaction Campaign

Year: 2019

System: Brakes (50)

Sequence: 01

First Release Rev: 0.1

**Title: Brake Line Parts Update**

**Applicability:** MY20 Revero GT Demos

**Market Region:** All

6. Proceed to unbolt the indicated line (C131125600202 Assembly - Brake Line Mid Rear RH) in (Fig.12a) from the union behind the upright and under the rocker panel (Fig 12b). The Rocker Trim panel should be unclipped as indicated before to facilitate the removal of the Brake line #1.

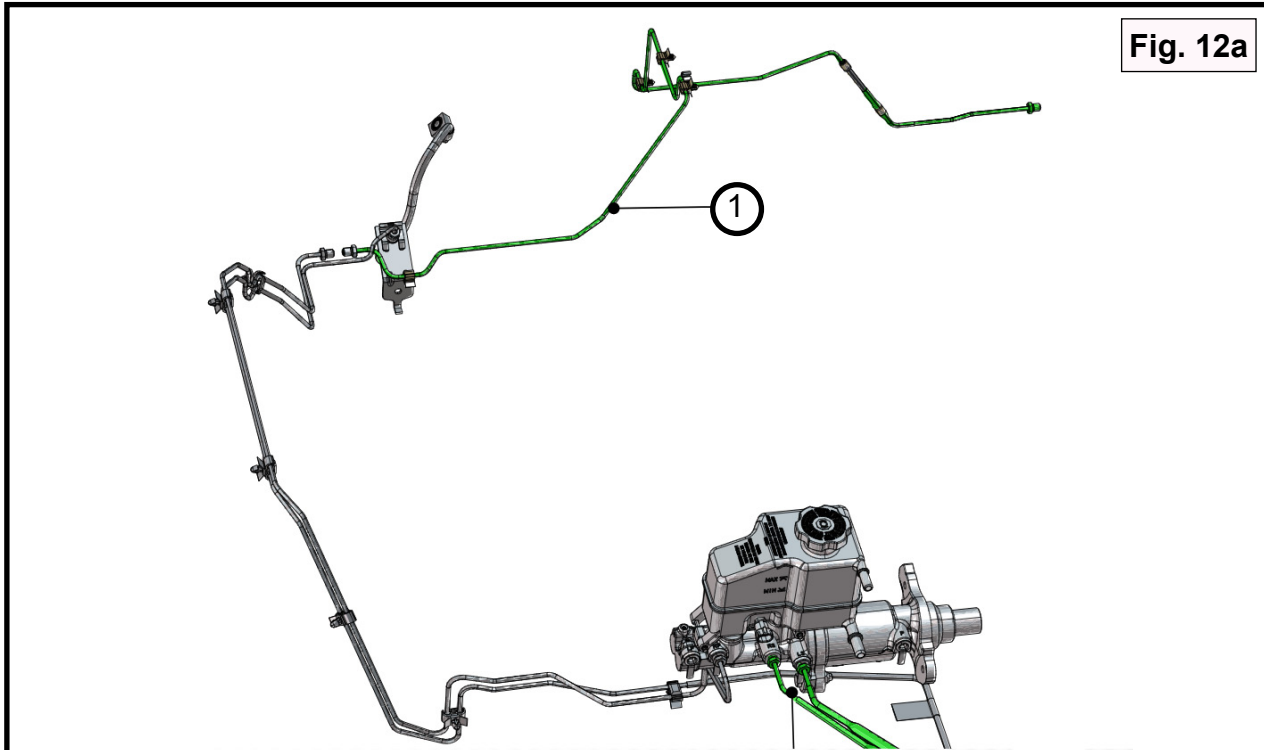

Fig. 12a



Fig. 12b

Karma Automotive Bulletins and service documents are intended for use by experienced and trained Technicians. If you lack the skills, tools, equipment and a suitable workshop for any procedure described in this document, we suggest you leave such repairs to a Karma retailer and service provider. See your service provider for advice on whether your vehicle may benefit from the information contained within this document. The information contained in the Karma Bulletin is accurate at the date of publication. However, Karma Automotive regularly updates technical information. Please check with your Karma Automotive Retailer and Karma Automotive service provider that the bulletin you intend to use contains the latest available information.

Type: Satisfaction Campaign

Year: 2019

System: Brakes (50)

Sequence: 01

First Release Rev: 0.1

**Title: Brake Line Parts Update****Applicability:** MY20 Revero GT Demos**Market Region:** All

7. The pipe is routed as shown in (fig. 13) remove the fastening clips (one is fastened torque as shown on install) to extract the line. There is also a union to disassemble the pipes here behind the upright. (torque 17 +/- 1Nm as shown)

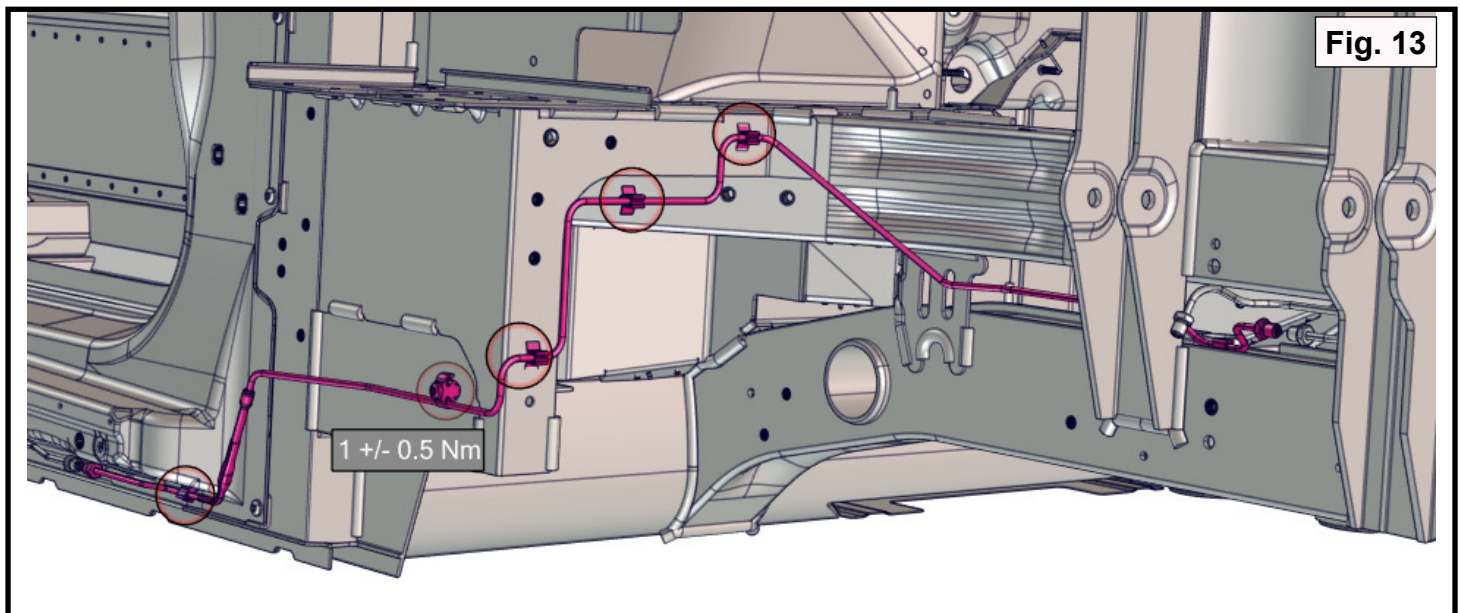

Karma Automotive Bulletins and service documents are intended for use by experienced and trained Technicians. If you lack the skills, tools, equipment and a suitable workshop for any procedure described in this document, we suggest you leave such repairs to a Karma retailer and service provider. See your service provider for advice on whether your vehicle may benefit from the information contained within this document. The information contained in the Karma Bulletin is accurate at the date of publication. However, Karma Automotive regularly updates technical information. Please check with your Karma Automotive Retailer and Karma Automotive service provider that the bulletin you intend to use contains the latest available information.

Type: Satisfaction Campaign

Year: 2019

System: Brakes (50)

Sequence: 01

First Release Rev: 0.1

**Title: Brake Line Parts Update****Applicability:** MY20 Revero GT Demos**Market Region:** All

7. This image illustrates (Fig.15) the maneuvering brake line out of the wheel well. Replace using same path as removal to install.



8. Check and torque application to EBCM and all other unions

9. Check for leaks

10. Bleed brake system per Karma Sync service procedure

11. Check for leaks

12. Reinstall PTC and all PTC connections

13. Reinstall rocker panels and fender liners

14. Reinstall wheels

15. Reconnect 12V

16. Test drive carefully and ensure normal operation

Karma Automotive Bulletins and service documents are intended for use by experienced and trained Technicians. If you lack the skills, tools, equipment and a suitable workshop for any procedure described in this document, we suggest you leave such repairs to a Karma retailer and service provider. See your service provider for advice on whether your vehicle may benefit from the information contained within this document. The information contained in the Karma Bulletin is accurate at the date of publication. However, Karma Automotive regularly updates technical information. Please check with your Karma Automotive Retailer and Karma Automotive service provider that the bulletin you intend to use contains the latest available information.

Type: Satisfaction Campaign

Year: 2019

System: Brakes (50)

Sequence: 01

First Release Rev: 0.1

**Title: Brake Line Parts Update**

**Applicability:** MY20 Revero GT Demos

**Market Region:** All

**PARTS REQUIRED:**

PART NUMBER	DESCRIPTION	QUANTITY
C131125003500	Brake line Assembly- MC to EBCM Front LH	1
C131125003600	Brake line Assembly- MC to EBCM Front RH	1
C131125600202	Assembly – Brake Line Mid RH R	1
C131125001901	Assembly – Brake Line Mid Rear LH	1

**SHOP SUPPLIES if Required:**

PART NUMBER	DESCRIPTION	QUANTITY
C145010100000	Clip - Quarter turn w base 9.0	18

**SPECIAL TOOLS:**

DESCRIPTION
N/A

**CAUSAL PART:**

PART NUMBER	DESCRIPTION
C131125003500	Brake Line Assembly – MC to EBCM Front

**LABOR CODES:**

CODE	DESCRIPTION	TIME	DEFECT CODE
50-50-05-05	Brake Line Update	3.5	50-50-11-68

**SUBLET:**

CODE	DESCRIPTION	AMOUNT
FLU-002	Brake Fluid	as needed

**WARRANTY DISPOSITION:** This repair is covered under the New Vehicle Limited Warranty, in effect for four (4) years from the in-service date with no mileage limitation.

Karma Automotive Bulletins and service documents are intended for use by experienced and trained Technicians. If you lack the skills, tools, equipment and a suitable workshop for any procedure described in this document, we suggest you leave such repairs to a Karma retailer and service provider. See your service provider for advice on whether your vehicle may benefit from the information contained within this document. The information contained in the Karma Bulletin is accurate at the date of publication. However, Karma Automotive regularly updates technical information. Please check with your Karma Automotive Retailer and Karma Automotive service provider that the bulletin you intend to use contains the latest available information.