



Technical Bulletin 202 12.2019

Contents

Item	Subject	Model Affected
202.1	Electronic Systems Commissioning and Motorcycle Unlocking	Daytona MOT02™ 765
202.2	Electronic Systems Commissioning and Motorcycle Unlocking	Rocket 3 GT, Rocket 3 R, Rocket 3 TFC

Item: 202.1
Description: Electronic Systems Commissioning and Motorcycle Unlocking
Model Affected: Daytona MOTO2™ 765

 **Warning**

Make sure the motorcycle is stabilised and adequately supported.
A correctly supported motorcycle will help prevent it from falling.
An unstable motorcycle may fall, causing injury to the operator or damage to the motorcycle.

 **Warning**

Failure to download the latest calibrations to the above model(s) may cause an unsafe riding condition leading to loss of motorcycle control and an accident.

 **Warning**

Always use Automatic Model Selection when downloading calibrations.
Manual model selection must only be used when attempting to restart an interrupted or failed download, or if an incorrect model is detected by Automatic Model Selection.
Always ensure that the correct model is detected or selected before selecting a calibration for download and never attempt to download calibrations listed for an incorrect model.
Downloading calibrations for an incorrect model will cause a dangerous riding condition which may lead to loss of motorcycle control and an accident.

 **Caution**

Do not interrupt or cancel calibration downloads before they have completed.
If a calibration download is cancelled or interrupted before it has completed, the Electronic Control Module (ECM) will not operate in the normal way. This is because the operating system has been erased from ECM memory and has not yet been fully replaced. Under these circumstances, it will not be possible to use Automatic Model Detection when restarting the calibration download.
Turn the motorcycle ignition off for at least 60 seconds to allow the electronic systems to power down, then restart the calibration download using Manual Model Selection.
If a calibration download fails to restart, it may be necessary to follow a specific recovery process.

Note:

- **The current password for all downloads can be found at www.triumphonline.net.**
- **It is normal for DTCs to be stored after a download has completed. This is due to the download process interrupting CAN communications between the ECMs.**
- **After a download has completed, you will be prompted to check all ECMs for stored DTCs and erase them as necessary. This must be completed after all downloads are finished.**

Description

The above motorcycle(s) are delivered in a locked condition. In this condition, the engine will not start. When performing a Pre-Delivery Inspection on the above models, the motorcycle's electronic systems must be commissioned and the motorcycle unlocked before the engine can be started.

Dealers are requested to commission the electronic systems and unlock the motorcycle by performing the following operations:

1. Download the latest TFT Instrument calibration.
2. Download the latest Engine ECM calibration.
3. Unlock the Engine ECM.

Preparation

Download and install the latest version of the Triumph Diagnostic Tool to your computer as described in the Triumph Diagnostic Tool Installation Guide. Triumph Diagnostic Tool Version 2019-06 or later is required to complete this procedure.

Note:

- **It can take up to 50 minutes to complete the system downloads necessary to commission the above motorcycle.**
 - **Please take the following precautions to avoid accidental disruption of the calibration downloads performed during this process.**
1. If using a laptop computer to run the diagnostic software, make sure the laptop battery is fully charged. Connect a charger to avoid draining the laptop battery.
 2. Disable any sleep and screen saver settings. The PC/laptop must remain turned on and awake for the duration of the process.
 3. Make sure all other PC/laptop applications (including Internet browsers) are closed down.
 4. Make sure the motorcycle battery is fully charged (battery voltage of at least 12.8 Volts). Connect an approved battery charger (suitable for use with maintenance free batteries) to maintain the battery charge during this process.
 5. During calibration download, DO NOT do the following unless instructed to do so by the diagnostic tool:
 - Turn the ignition OFF.
 - Switch the engine stop switch to a different position.
 - Disconnect the diagnostic interface.

Initial Steps

1. Unpack the motorcycle as described in the Motorcycle Unpacking Guide.
2. Assemble the motorcycle as described in the Motorcycle Assembly Guide.
3. Ensure that the motorcycle battery is fully charged and installed as described in the service manual.
4. Remove the rider's seat.
5. Connect the Triumph Diagnostic Tool to the motorcycle as described in the Triumph Diagnostic Tool User Guide and turn the ignition switch ON.

Instruments Calibration Download

Note:

- The instrument calibration has a large file size and may include updates to the instrument graphics. It can take up to 40 minutes for the TFT instrument downloads to complete.
1. Switch the engine stop switch to the STOP (OFF) position.

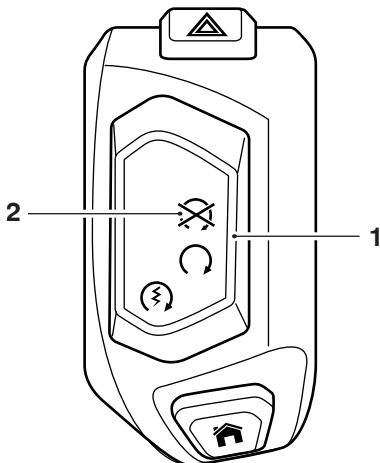

1. Engine stop switch
2. STOP (OFF) position

2. Download the latest instrument calibration as normal, using automatic model detection.

Note:

- During the download, the instrument display will turn off and the red immobiliser/alarm LED will flash.
- Multiple files are transferred during the download. The progress bar displayed on the diagnostic tool may repeatedly rise from 0% to 100% as each file is downloaded.
- Do not assume the download has completed when the instrument display turns back on. Always wait for the Verifying Download screen to appear to confirm the download has successfully completed.
- If the download is accidentally disrupted or does not complete for any reason, turn the ignition off for at least 60 seconds then restart the download using Manual Model Selection. If the download fails to restart normally, follow the recovery process detailed in Technical Bulletin 191.

Engine ECM Calibration Download

1. Switch the engine stop switch to the RUN (ON) position.

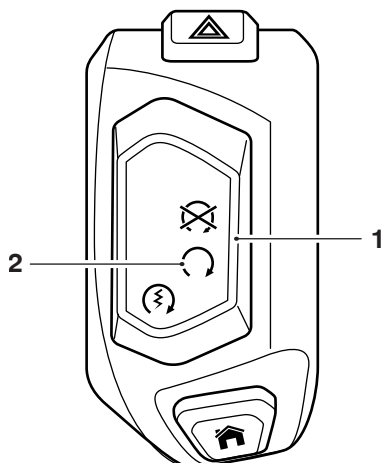

1. **Engine stop switch**
2. **RUN (ON) position**

2. Download the latest engine ECM calibration as normal, using automatic model detection.

Note:

- If the download is accidentally disrupted or does not complete for any reason, turn the ignition off for at least 60 seconds then restart the download using Manual Model Selection.

Unlock the Engine ECM

1. Unlock the engine ECM as described in the Triumph Diagnostic Tool User Guide.

Note:

- There is a small delay while the instruments are checked for up-to-date calibrations.
- The software will report if any calibrations are out of date and will prevent unlocking until the correct calibrations are installed.
- The unlock code can be found at www.triumphonline.net.

Final Steps

- Check and erase all stored Immobiliser, Engine ECM and ABS DTCs.
- Disconnect the Triumph Diagnostic Tool.
- Refit the rider's seat.
- Check that the motorcycle can be powered ON and started using each key.
- Set the instruments to display the correct language and units for your region, as described in the Owners Handbook.

Item: 202.2
Description: Electronic Systems Commissioning and Motorcycle Unlocking
Model Affected: Rocket 3 GT, Rocket 3 R, Rocket 3 TFC

 **Warning**

Make sure the motorcycle is stabilised and adequately supported.
A correctly supported motorcycle will help prevent it from falling.
An unstable motorcycle may fall, causing injury to the operator or damage to the motorcycle.

 **Warning**

Failure to download the latest calibrations to the above model(s) may cause an unsafe riding condition leading to loss of motorcycle control and an accident.

 **Warning**

Always use Automatic Model Selection when downloading calibrations.
Manual model selection must only be used when attempting to restart an interrupted or failed download, or if an incorrect model is detected by Automatic Model Selection.
Always ensure that the correct model is detected or selected before selecting a calibration for download and never attempt to download calibrations listed for an incorrect model.
Downloading calibrations for an incorrect model will cause a dangerous riding condition which may lead to loss of motorcycle control and an accident.

 **Caution**

Do not interrupt or cancel calibration downloads before they have completed.
If a calibration download is cancelled or interrupted before it has completed, the Electronic Control Module (ECM) will not operate in the normal way. This is because the operating system has been erased from ECM memory and has not yet been fully replaced. Under these circumstances, it will not be possible to use Automatic Model Detection when restarting the calibration download.
Turn the motorcycle ignition off for at least 60 seconds to allow the electronic systems to power down, then restart the calibration download using Manual Model Selection.
If a calibration download fails to restart, it may be necessary to follow a specific recovery process.

Note:

- **The current password for all downloads can be found at www.triumphonline.net.**
- **It is normal for DTCs to be stored after a download has completed. This is due to the download process interrupting CAN communications between the ECMs.**
- **After a download has completed, you will be prompted to check all ECMs for stored DTCs and erase them as necessary. This must be completed after all downloads are finished.**

Description

The above motorcycle(s) are delivered in a locked condition. In this condition, the engine will not start. When performing a Pre-Delivery Inspection on the above models, the motorcycle's electronic systems must be commissioned and the motorcycle unlocked before the engine can be started.

Dealers are requested to commission the electronic systems and unlock the motorcycle by performing the following operations:

1. Download the latest TFT Instrument calibration.
2. Download the latest Keyless ECM calibration.
3. Download the latest Engine ECM calibration.
4. Unlock the Engine ECM.
5. Adapt the crankshaft position (if required).

Preparation

Download and install the latest version of the Triumph Diagnostic Tool to your computer as described in the Triumph Diagnostic Tool Installation Guide. Triumph Diagnostic Tool Version 2019-07 or later is required to complete this procedure.

Note:

- **It can take up to 50 minutes to complete the system downloads necessary to commission the above motorcycle.**
 - **Please take the following precautions to avoid accidental disruption of the calibration downloads performed during this process.**
1. If using a laptop computer to run the diagnostic software, make sure the laptop battery is fully charged. Connect a charger to avoid draining the laptop battery.
 2. Disable any sleep and screen saver settings. The PC/laptop must remain turned on and awake for the duration of the process.
 3. Make sure all other PC/laptop applications (including Internet browsers) are closed down.
 4. Make sure the motorcycle battery is fully charged (battery voltage of at least 12.8 Volts). Connect an approved battery charger (suitable for use with maintenance free batteries) to maintain the battery charge during this process.
 5. During calibration download, DO NOT do the following unless instructed to do so by the diagnostic tool:
 - Turn the ignition OFF.
 - Switch the engine stop switch to a different position.
 - Disconnect the diagnostic interface.

Initial Steps

1. Unpack the motorcycle as described in the Motorcycle Unpacking Guide.
2. Assemble the motorcycle as described in the Motorcycle Assembly Guide.
3. Ensure that the motorcycle battery is fully charged and installed as described in the Service Manual.

Note:

- The motorcycle is supplied with one smart key and two standard keys.
- The smart key has two modes of operation, active mode and passive mode.
- With the smart key in active mode, the motorcycle can be powered ON when the smart key is positioned within 1 metre (3 feet) of the Low Frequency (LF) antenna.
- There is an LF antenna located on the left hand side of the rear mudguard, and another located under the flyscreen.
- With the smart key in passive mode, the key must be positioned against the LF antenna located on the left hand side of the rear mudguard to power the motorcycle ON.
- Standard keys must be positioned against the LF antenna located on the left hand side of the rear mudguard to power the motorcycle ON.
- The smart key should be set to active mode and kept within 1 metre (3 feet) of the LF antenna for the duration of this procedure.

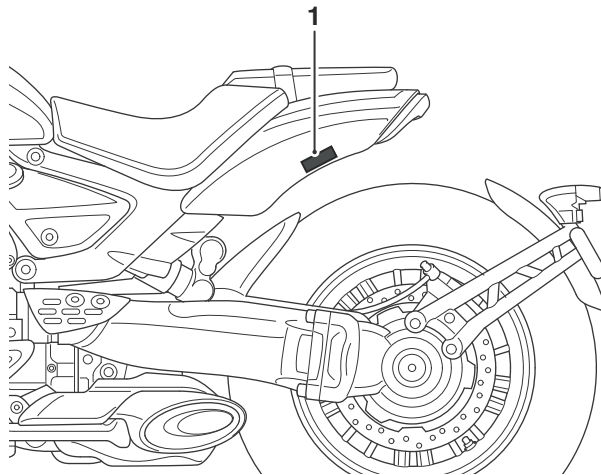

1. LF Antenna Location

4. Check the smart key is in active mode. Press the smart key button and ensure the LED flashes green. If the LED flashes red, press and hold the button until the LED changes to green.
5. Remove the rider's seat.

-
6. **US markets Only:** Turn the master ignition switch to the ON position.

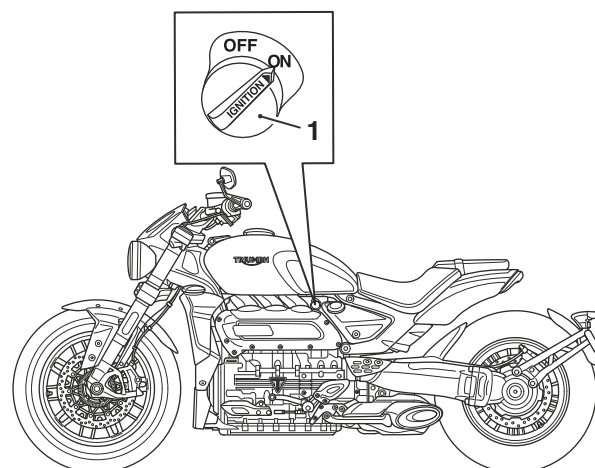

1. Master Ignition Switch

7. Connect the Triumph Diagnostic Tool to the motorcycle as described in the Service Manual and turn the ignition ON.

Keyless ECM Calibration Download

1. Download the latest Keyless ECM calibration as normal, using automatic model detection.

Note:

- It will take approximately three minutes for the Keyless ECM calibration download to complete.
- If the download is accidentally disrupted or does not complete for any reason, turn the ignition off for at least 60 seconds then restart the download using Manual Model Selection.
- If the download cannot be restarted or fully completed by the normal method, it may be necessary to re-pair the immobiliser system components before re-attempting the download. Refer to the 'Keyless ECM Calibration - Failed Download Recovery Flow Chart' provided in the Service Manual.

Instruments Calibration Download

Note:

- The instrument calibration has a large file size and may include updates to the instrument graphics. It can take up to 40 minutes for the TFT instrument downloads to complete.
- During the instrument download, the diagnostic tool will check if the instruments have a valid VIN stored.
- If the instruments do not have a valid VIN stored, the diagnostic software will automatically read the VIN from the Engine ECM and program it into the Instruments. The engine stop switch must be in the RUN position to allow the diagnostic tool to communicate with the Engine ECM.
- There may be a short delay at the start of the download while this function is carried out. During this delay the download progress bar will remain at 0%. The download progress bar will begin to advance when the VIN check function is complete.
- If a valid VIN cannot be obtained from the Engine ECM, you will be prompted to manually enter the motorcycle's 17 digit VIN. The manually entered VIN will then be programmed to the instruments before the download process is completed.
- During the download, the instrument display will turn off and the red immobiliser/alarm LED will flash.
- Multiple files are transferred during the download. The progress bar displayed on the diagnostic tool may repeatedly rise from 0% to 100% as each file is downloaded.
- Do not assume the download has completed when the instrument display turns back on. Always wait for the Verifying Download screen to appear to confirm the download has successfully completed.
- If the download is accidentally disrupted or does not complete for any reason, turn the ignition off for at least 60 seconds then restart the download using Manual Model Selection. If the download fails to restart normally, refer to the 'Instrument Calibration - Failed Download Recovery Flow Chart' provided in the Service Manual.

1. Make sure the engine stop switch is in the RUN (ON) position.

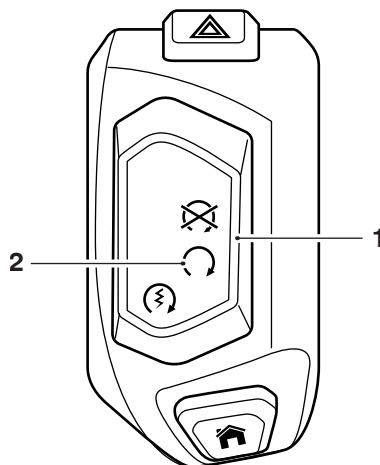

1. **Engine stop switch**
2. **RUN (ON) position**

2. Download the latest instrument calibration as normal, using automatic model detection.

Caution

The motorcycle VIN can only be programmed to the instruments once.
Once programmed, the VIN cannot be overwritten or corrected by the Triumph diagnostic tool.
If prompted to manually enter the VIN, always make sure that the VIN entered is correct and exactly matches the VIN stamped on the motorcycle's frame before clicking OK.
It will not be possible to activate certain features of the connectivity module if the instruments are programmed with an incorrect/invalid VIN.

3. If prompted, enter the motorcycle's 17 digit VIN. Alphabetical characters must be entered in upper case. Re-enter the VIN to confirm it is correct before clicking OK.

TRIUMPH  **Enter VIN**

Please enter the 17 digit VIN in UPPER CASE

Enter VIN

Invalid VIN entered

Confirm VIN

Invalid VIN entered

OK Cancel

Engine ECM Calibration Download

Note:

- The Engine ECM calibration has a large file size. It will take approximately seven minutes for the calibration download to complete.
1. Download the latest Engine ECM calibration as normal, using automatic model detection.

Note:

- If the download is accidentally disrupted or does not complete for any reason, turn the ignition off for at least 60 seconds then restart the download using **Manual Model Selection**.

Unlock the Engine ECM

1. Unlock the Engine ECM as described in the Triumph Diagnostic Tool User Guide.

Note:

- There is a small delay while the instruments are checked for up-to-date calibrations.
- The software will report if any calibrations are out of date and will prevent unlocking until the correct calibrations are installed.
- The unlock code can be found at www.triumphonline.net.

Adapt the Crankshaft Position (if required) - Euro 5 Markets Only

Motorcycles are typically delivered from the factory with the crankshaft position adapted. However, a small number of models may need to have the crankshaft position adapted at PDI.

Check the Engine ECM for stored DTCs. If the crankshaft position is not adapted, DTC P0315 will be stored and the Malfunction Indicator Light (MIL) will be illuminated. DTC P0315 cannot be erased by using the Erase DTCs function. To clear the DTC the crankshaft position must be adapted as described in the adaption process below.

If DTC P0315 is not present at PDI, it is not necessary to adapt the crankshaft position.

Crankshaft Position Adaption Process

Warning

Exhaust fumes are poisonous, always operate a motorcycle in the open-air or in an area with adequate ventilation.

Do not operate a motorcycle in an enclosed area without adequate ventilation.

Operating a motorcycle in an enclosed area without adequate ventilation can cause loss of consciousness and death within a short period of time.

1. Turn the motorcycle ignition Off for at least 60 seconds.
2. Turn the motorcycle ignition ON. Make sure the engine Stop switch is in the RUN position.
3. Make sure the transmission is in neutral.
4. Navigate to ENGINE DIAGNOSTICS - Function Tests.
5. Select Crankshaft Position Adaption and click **Start**.
6. Follow the on screen instructions.
7. When the adaption has completed, click **Finish** and turn the motorcycle ignition Off for at least 60 seconds.

Note:

- **DTC P0315 will not clear until the motorcycle's electronic system has fully powered down.**
8. Turn the motorcycle ignition ON. Make sure that DTC P0315 and the MIL have cleared.

Refer to the Service Manual for more details on the crankshaft position adaption process.

Final Steps

- Check and erase all stored Immobiliser, Engine ECM and ABS DTCs.
- Disconnect the Triumph Diagnostic Tool.
- Refit the rider's seat.
- Check that the motorcycle can be powered ON and started using each key.
- Set the instruments to display the correct language and units for your region, as described in the Owners Handbook.

Circulation

Initial and date when read and return to central file holder

Service Manager	Parts Manager	Sales Manager	Workshop Supervisor	Technician 1	Technician 2