

JLRTB02012NAS1

TECHNICAL BULLETIN

18 DEC 2019



© Jaguar Land Rover North America, LLC

NOTE: The information in Technical Bulletins is intended for use by trained, professional Technicians with the knowledge, tools, and equipment required to do the job properly and safely. It informs these Technicians of conditions that may occur on some vehicles, or provides information that could assist in proper vehicle service. The procedures should not be performed by 'do-it-yourselfers'. If you are not a Retailer, do not assume that a condition described affects your vehicle. Contact an authorized Land Rover service facility to determine whether this bulletin applies to a specific vehicle.

INFORMATION

SECTION:

418-02

SUBJECT/CONCERN:

'Gearbox Fault Detected' Displayed On The Instrument Panel Cluster (IPC)

AFFECTED VEHICLE RANGE:

MODEL:	MODEL YEAR:	VIN:	ASSEMBLY PLANT:
I-PACE (X590)	2019-2020	F60094-F80069	Graz (Austria)

MARKETS:

NORTH AMERICA

CONDITION SUMMARY:

SITUATION:

A 'Gearbox Fault Detected' warning message may be displayed on the Instrument Panel Cluster (IPC). If the vehicle is in PARK, the customer may not be able to select DRIVE or, if already in DRIVE, the customer may experience a ratcheting type noise followed by an abrupt stop when the vehicle speed has reduced to 5 km/h (3 mph).

The following Diagnostic Trouble Code(s) (DTC)s will also be stored in the Powertrain Control Module (PCM):

- P07E4-00
- P272C-13
- P303F-15
- P303F-29
- P07E6-00
- P272C-11

CAUSE:

No retention to the front Electric Drive Unit (EDU) causing strain on wiring going to the park lock actuator connector (C1YE113A).

ACTION:

Follow the instructions below.

PARTS:

PART NUMBER	DESCRIPTION	QUANTITY
T2R29347	Air Conditioning (A/C) O-ring kit	1
T4K12931	Engine compartment wiring harness	1
J9D11114	Front EDU to subframe bolts	2
C2Z22224	Front EDU upper mounting nuts/stabilizer bar link lower nuts	4

PART NUMBER	DESCRIPTION	QUANTITY
T2H3774	Front subframe to body bolts M12/rear lower control arm bolts	6
T2H3162	Front subframe to body bolts M14	2
T4K5106	Front lower control arm bolts	2
T4K12935	Ground cable	1
T4A12521	Halfshaft circlip	2
T2H5007	Lower control arm nuts	4
XR857426	Steering column lower shaft lower bolts	1
T2H5057	Steering gear boot inner clips	2
T4N8037	Tie-rod end nuts	2
T2H17786	Yoke retaining bolts	2

WARRANTY:**NOTES:**

- Repair procedures are under constant review, and therefore times are subject to change; those quoted here must be taken as guidance only. Use TOPIx to obtain the latest repair time.
- The JLR claims submission system requires the use of causal part numbers. Labor only claims must show the causal part number with a quantity of zero.

DESCRIPTION	SRO	TIME (HOURS)	CONDITION CODE	CAUSAL PART
Front compartment wiring harness - Renew	86.71.37	11.2	B4	T4K7182/T4K7184/T4K6641

NOTE:

Normal Warranty procedures apply.

SERVICE INSTRUCTION:

1.

NOTE:

Make sure any other related repairs are completed before continuing with this technical bulletin.



E256857



Refer to the TOPIx Workshop Manual section 100-00: General Information - Description and Operation - Diagnostic Trouble Code Index DTC: Powertrain Control Module (PCM) for diagnosis and testing information relating to DTCs P07E4-00, P272C-13, P303F-15, P303F-29, P07E6-00 and P272C-11.

- ■ If the park lock actuator connector (C1YE113A) wiring is found to be damaged, as per the illustration, **continue to step 2.**

2.

NOTE:

Before renewing the front compartment wiring harness, read the 'Service Information' section below.

Renew the front compartment wiring harness (see TOPIx Workshop Manual section 418-02: Wiring Harnesses - Removal and Installation - Front Compartment Wiring Harness).

3. An Electronic Product Quality Report (EPQR) must be submitted to provide a clear photograph of the original damaged wiring harness installed on the vehicle. See step 1 for example photographs.

SERVICE INFORMATION:

The following steps must be completed before installing the updated front compartment wiring harness.

NOTES:

- Some variation in the illustrations may occur, but the essential information is always correct.
- Some components are shown removed for clarity.

1.

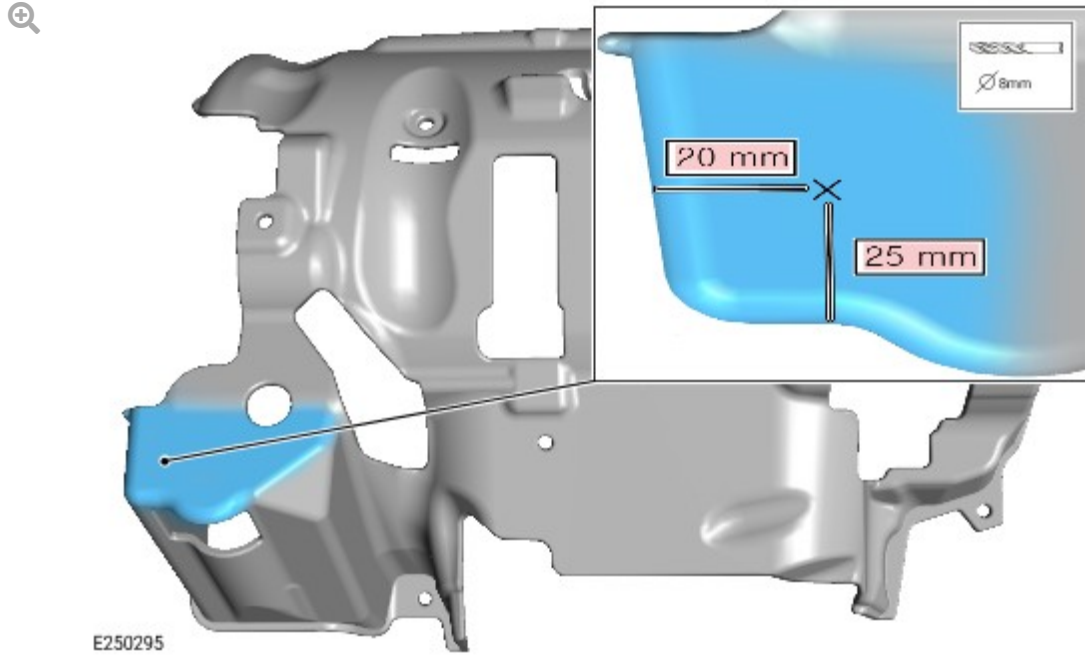

Using a suitable tool, create a hole in the EDU upper Noise, Vibration and Harshness (NVH) cover, as shown in the illustration.

2.

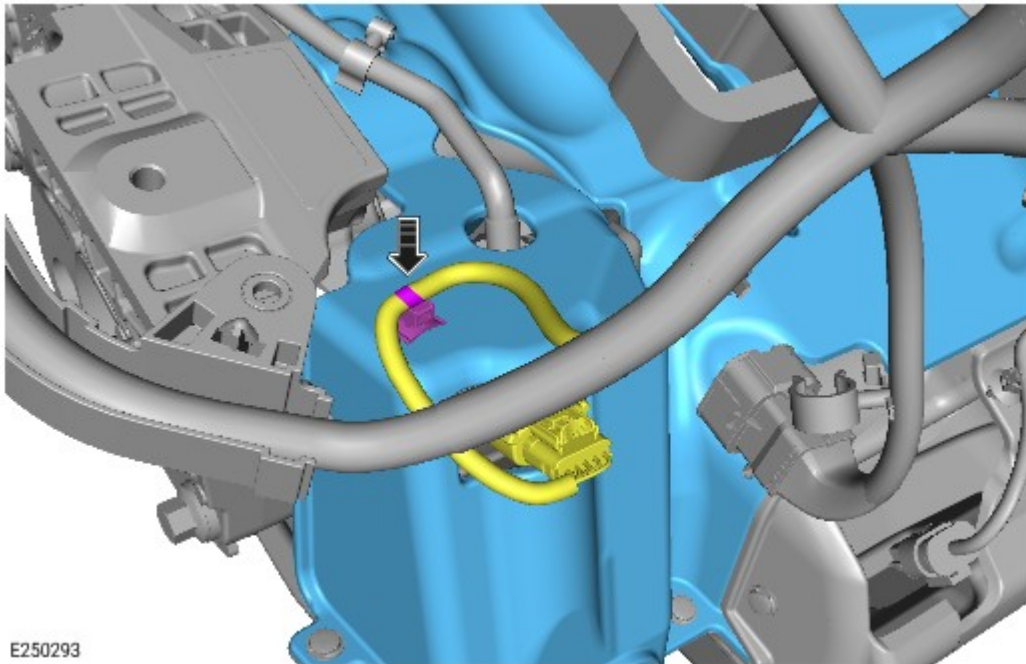

During the installation of the front EDU, make sure the new wiring harness clip is installed in the NVH cover, as shown in the illustration.

3.

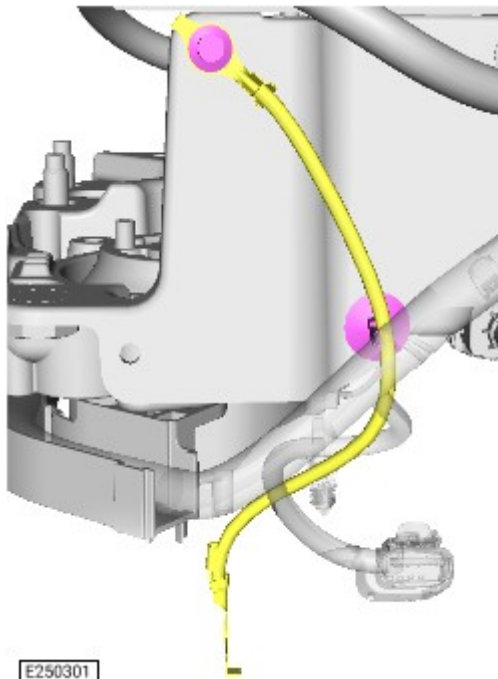

Remove and discard the front EDU ground cable.

- ■ Release the retaining clip.
- ■ Remove the bolt.

4.

NOTE:

Make sure the new front EDU ground cable is routed through the loop formed by the park lock actuator break out harness, as shown in the illustration.

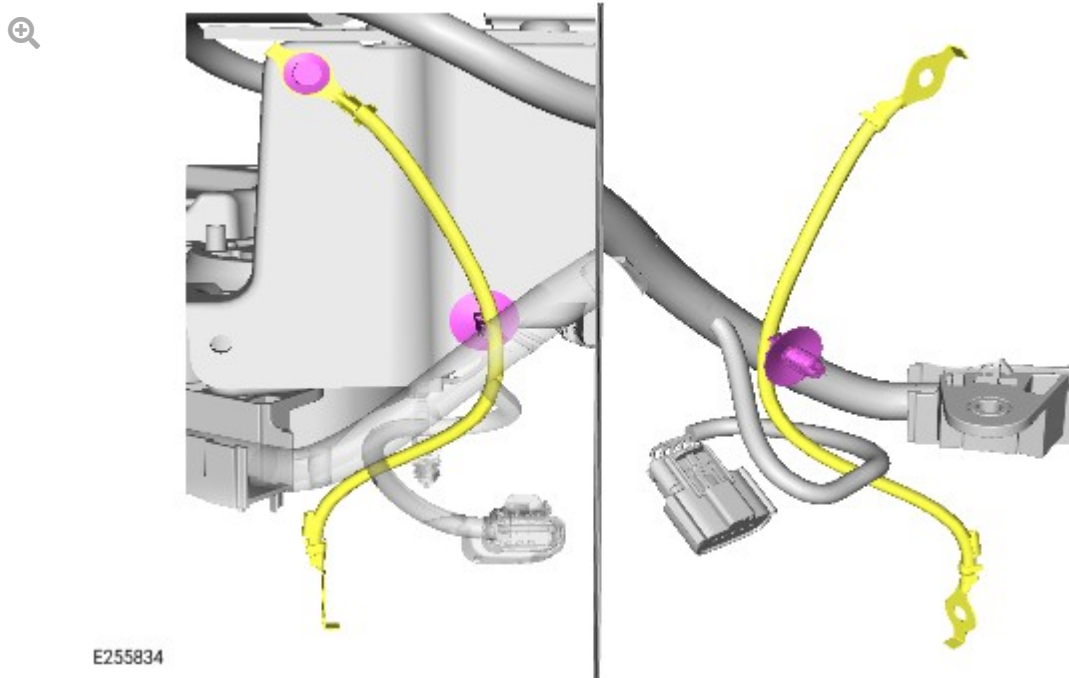

Install the new front EDU ground cable.

- ■ Secure the ground cable with the retaining clip.
- ■ Tighten the bolt.
 - ■ Torque: **24 Nm**