

- ATTENTION:**
- GENERAL MANAGER
 - PARTS MANAGER
 - CLAIMS PERSONNEL
 - SERVICE MANAGER

IMPORTANT - All Service Personnel Should Read and Initial in the boxes provided, right.

© 2019 Subaru of America, Inc. All rights reserved.



QUALITY DRIVEN® SERVICE

SERVICE BULLETIN

APPLICABILITY: 2012-16MY Impreza
 2013-17MY Crosstrek
 2014-18MY Forester
 2015-18MY WRX and WRX STI

SUBJECT: HVAC Blower Fan Inoperative

NUMBER: 10-96-19
DATE: 12/13/19

INTRODUCTION:

This bulletin announces availability of new HVAC blower motor unit assemblies developed to address isolated concerns of the blower motor becoming inoperative. If this issue occurs on models with Auto A/C, the blower fan may become totally inoperative. If this issue occurs on models with Manual A/C, the blower fan may operate on high speed only. The root cause of these conditions is water intrusion into the blower motor causing rust and corrosion to develop. Over time, the blower motor may begin to draw more electrical current to operate. If that occurs, the additional draw can cause the related fuse and/or the blower resistor to fail. To address this condition, additional packing has been added to improve sealing of the blower unit case along with development of a new style cabin air filter which also incorporates improved sealing.

PRODUCTION CHANGE INFORMATION:

The improved blower motor units were incorporated into production as per the table here.

Model	Starting VIN
Forester	JH576848
WRX & WRX STI	J9838468

PART INFORMATION:

Description	Part Number	Note
BLOWER & COOLING UNIT	72210FJ033	Models w/ AUTO A/C
	72210FJ043	Models w/ MANUAL A/C
CABIN AIR FILTER **	72880FJ000	For use with new blower units

REMINDER: Always order the most up-to-date replacement parts based on the specific VIN being repaired.

****NOTE:** The new filter, p.n. **72880FJ000** can be used in place of the prior p.n. **72880FG000** but not vice-versa.

<p>CAUTION: VEHICLE SERVICING PERFORMED BY UNTRAINED PERSONS COULD RESULT IN SERIOUS INJURY TO THOSE PERSONS OR TO OTHERS.</p> <p>Subaru Service Bulletins are intended for use by professional technicians ONLY. They are written to inform those technicians of conditions that may occur in some vehicles, or to provide information that could assist in the proper servicing of the vehicle. Properly trained technicians have the equipment, tools, safety instructions, and know-how to do the job correctly and safely. If a condition is described, DO NOT assume that this Service Bulletin applies to your vehicle, or that your vehicle will have that condition.</p>	<p style="text-align: center;">Subaru of America, Inc. is ISO 14001 Compliant</p> <p>ISO 14001 is the international standard for excellence in Environmental Management Systems. Please recycle or dispose of automotive products in a manner that is friendly to our environment and in accordance with all local, state and federal laws and regulations.</p>
--	--

Continued...

SERVICE PROCEDURE / INFORMATION:

REMINDER: Customer satisfaction and retention starts with performing quality repairs.

The service procedures for replacing the blower motor unit remain unchanged. Always refer to the applicable Service Manual and review the full requirements of the repair being performed. The Service Manual procedures contain information critical to performing an effective repair the first time and every time. This includes but is not limited to: important SAFETY precautions, proper inspection criteria, necessary special tools, required processes and related one-time-use parts needed for a complete and lasting repair.

NOTES: Since ECM removal is necessary per the Service Manual procedure, battery disconnect is required. Always make sure to record (and reset when repairs are completed) the customer's radio station presets and Navigation Favorites (where applicable).

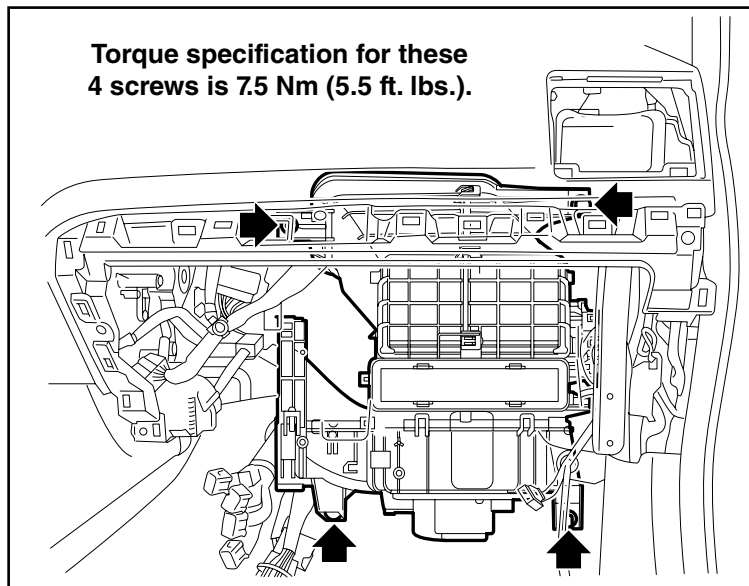

WARRANTY / CLAIM INFORMATION:

For vehicles within the Basic New Car Limited Warranty period or covered by an active Subaru Added Security Classic or Gold plan, this repair may be submitted using the following claim information:

Labor Description	Labor Operation #	Labor Time	Fail Code
Blower Housing R&R	B725-001	0.7	YDB-35

IMPORTANT REMINDERS:

- SOA strongly discourages the printing and/or local storage of service information as previously released information and electronic publications may be updated at any time.
- Always check for any open recalls or campaigns anytime a vehicle is in for servicing.
- Always refer to STIS for the latest service information before performing any repairs.