

Constellation > 4900 Models  
 Heritage > 5700 Models  
 > 4700 Models 5900 Models  
 4800 Models > 6900 Models

## General Information

Beginning 04/01/2019 Western Star cab doors were updated to a new style regulator and window. When replacing an older style regulator or window the vehicle must be retrofitted to the new style regulator and window.

To replace the old style window regulator and glass window, the interior trim panel, regulator, and window glass must first be removed.

## Parts

Parts are available from the PDCs. See Table 1 for left-hand door replacement parts, and Table 2 for right-hand door replacement parts.

Parts Required—LH Door		
Item Description	Part Number	Qty
Regulator LH manual	A18-71372-000	1
Regulator LH power	A18-71371-000	1
LH Door Glass	18-71373-000	1

Table 1, Parts Required—LH Door

Parts Required—RH Door		
Item Description	Part Number	Qty
Regulator RH manual	A18-71372-001	1
Regulator RH power	A18-71371-001	1
RH Door Glass	18-71373-001	1

Table 2, Parts Required—RH Door

## Window Regulator Retrofit Instructions

### Trim Panel and Window Glass Removal

1. Park the vehicle, shut down the engine, and apply the parking brakes. Chock the tires.
2. Pull the switches off the top of the upper door trim panel, then disconnect the wiring.
3. Remove the manual window crank handle, if equipped.
4. Remove the knob from the end of the lock rod.
5. Remove the four screws from the interior release handle. The handle must be held up to access two of the screws. Leave the handle in place.
6. Remove the upper trim panel.
  - 6.1 Remove the two screws from the bottom of the pull cup. See [Fig. 1](#).

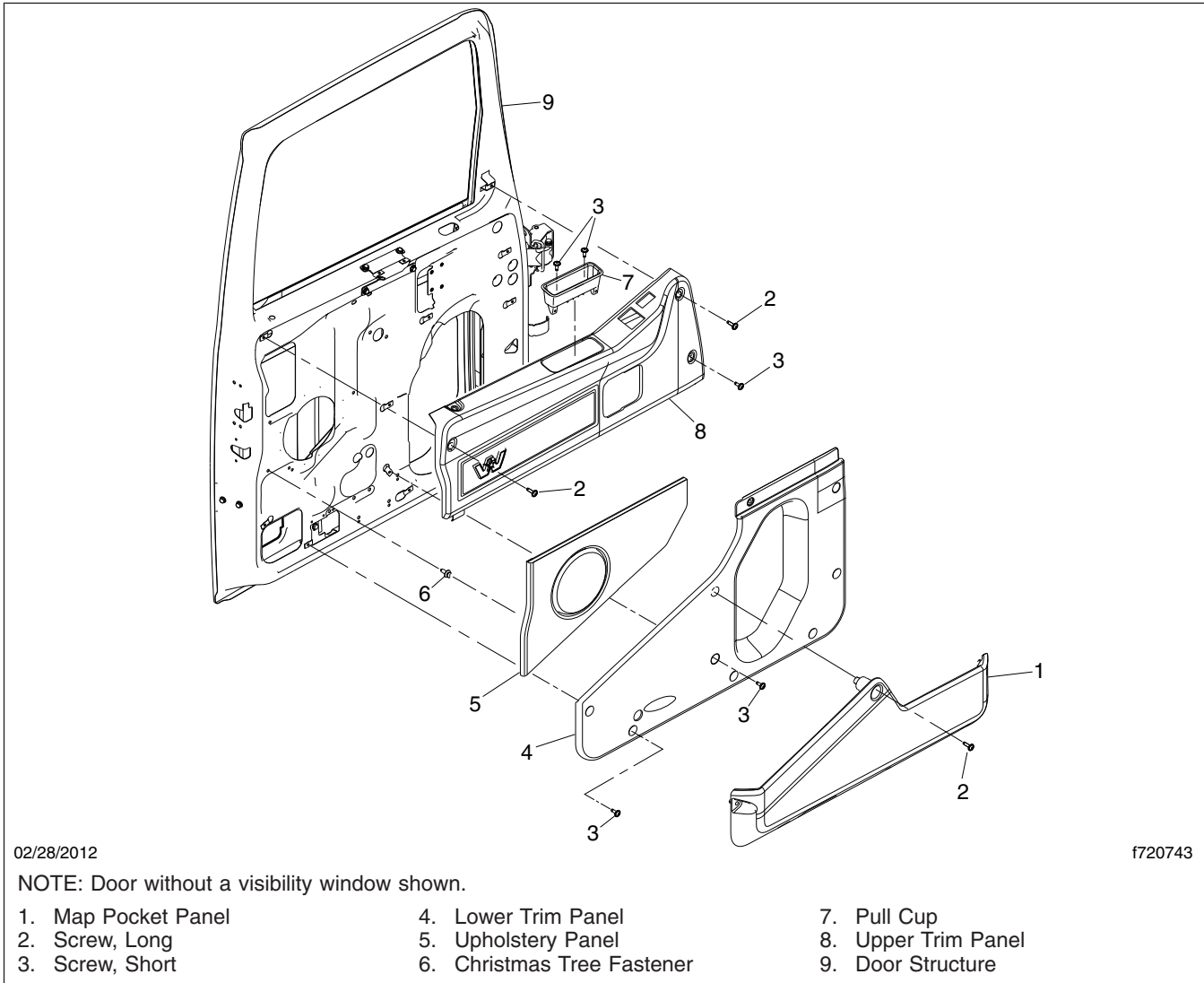

**Fig. 1, Door Trim Panels, Vehicles Built From November 7, 2011—**

- 6.2 Remove the three screws that attach the upper trim panel to the door.
- 6.3 Slide the upper trim panel up to disengage the hook (behind the lower rear corner of the panel) from the door. Rotate the panel to allow the interior release handle to pass through the opening in the panel. Remove the panel, leaving the interior release handle in place on the door.
7. Remove the map pocket panel.
  - 7.1 Remove the screws that attach the map pocket panel to the lower trim panel and the door.
  - 7.2 Disconnect the courtesy lamp wiring behind the pocket, then remove the pocket panel. See [Fig. 2](#).

Constellation > 4900 Models  
 Heritage > 5700 Models  
 > 4700 Models 5900 Models  
 4800 Models > 6900 Models

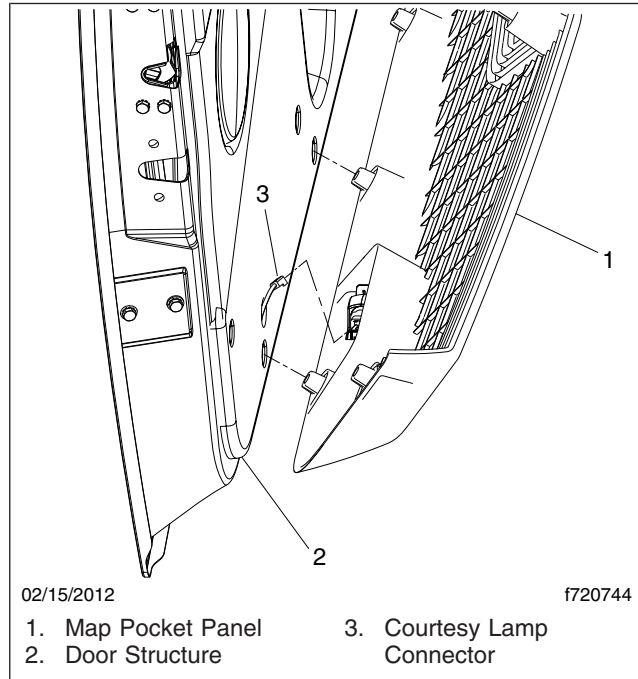

**Fig. 2, Courtesy Lamp Wiring Connector**

8. Remove the screws that attach the lower trim panel to the door.
9. Remove the lower trim panel. See [Fig. 3](#).

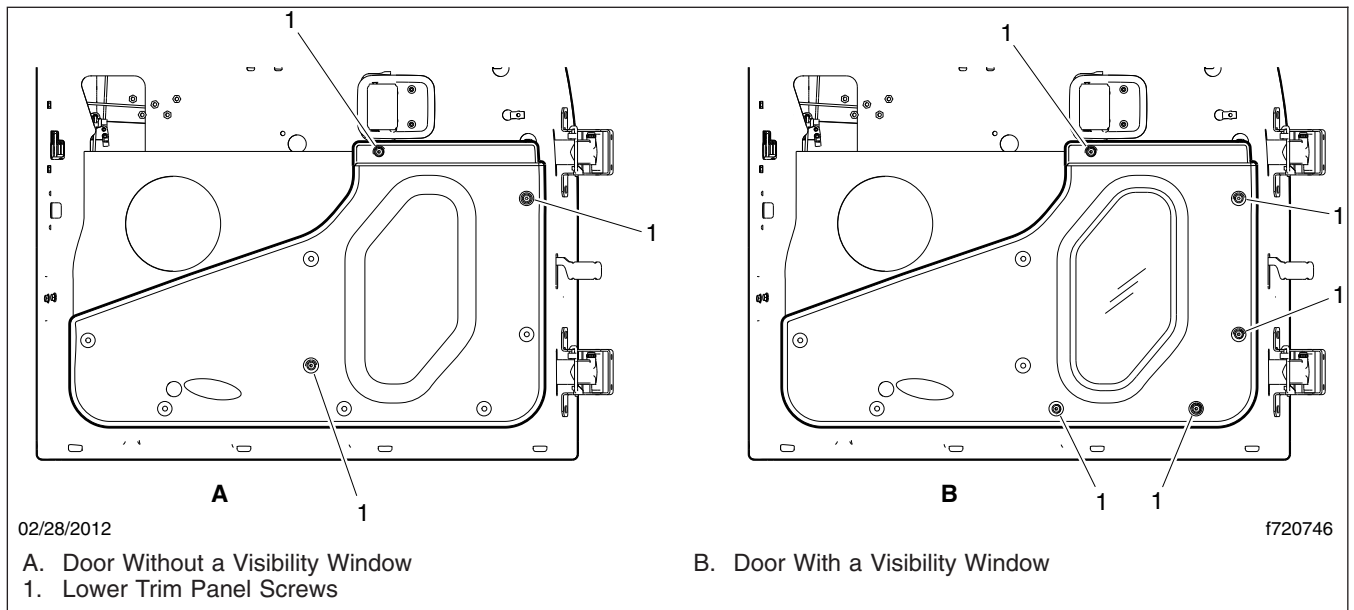

**Fig. 3, Lower Trim Panel Screw Locations**

10. Remove the fir tree fasteners holding the center upholstery panel to the door then remove the panel.
11. Move the vapor barrier out of the way of the access holes. See [Fig. 4](#).



**Fig. 4, Example of Vapor Barrier**

12. Remove the inner and outer window scraper seals by prying them up. See [Fig. 5](#).

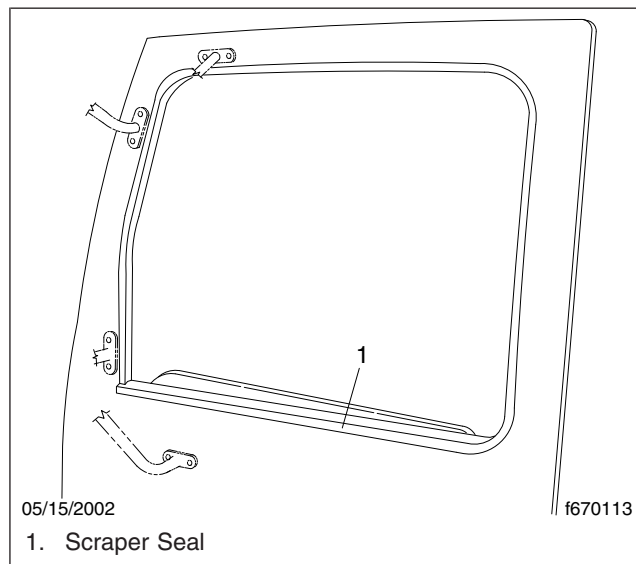

**Fig. 5, Cab Door Window**

13. Remove the top-window run channel seals by prying them out. See [Fig. 6](#).

Constellation  
Heritage  
> 4700 Models  
4800 Models

> 4900 Models  
> 5700 Models  
5900 Models  
> 6900 Models

Western Star  
Service Bulletin

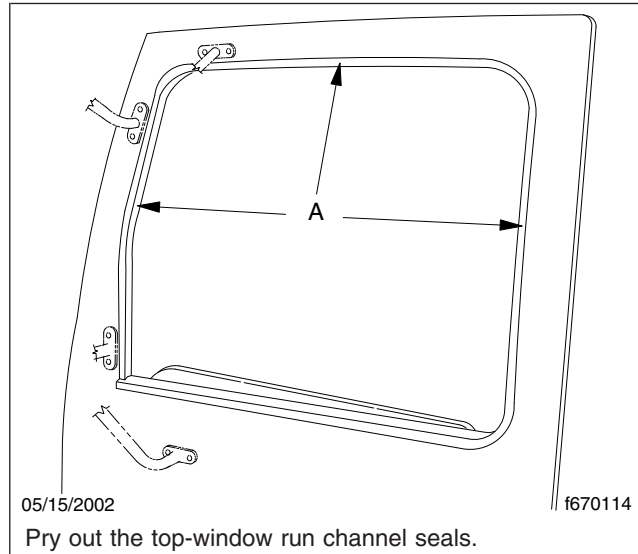

**Fig. 6, Top Run Channels**

14. If equipped, remove the upper mirror arm mounting-bracket screws and swing the arms to the side. See [Fig. 7](#). The lower arms do not need to be removed.

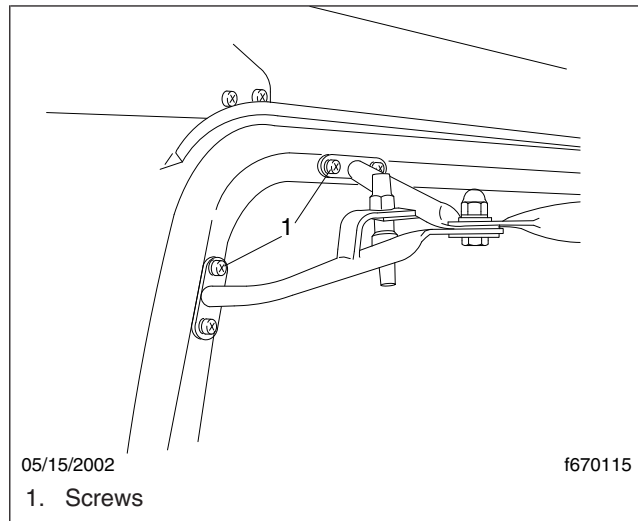

**Fig. 7, Upper Mirror Arm Mounting Screw Locations**

15. Remove the regulator.
  - 15.1 If the regulator is functional, crank or power the window down until the window mounting bolts are aligned with the two access holes in the inner door skin. See [Fig. 8](#).



**Fig. 8, Window Mounting**

- 15.2 If the regulator is non-functional, access and remove the nuts holding the window to the regulator by reaching through the cut-out for the visibility window or the hole for the door lock rods.

**⚠ WARNING**

**Wear protective gloves and safety glasses when replacing window glass. Gloves will protect your hands from sharp edges, and allow a better grip. Failure to wear gloves and safety glasses when handling glass could result in injury to hands or eyes.**

16. Through one of the door openings, hold the glass in place while removing the window mounting bolts. Slide the glass up and place a padded C-clamp over the top of the door to hold the glass. See [Fig. 9](#).

Constellation  
Heritage  
> 4700 Models  
4800 Models

> 4900 Models  
> 5700 Models  
5900 Models  
> 6900 Models

Western Star  
Service Bulletin

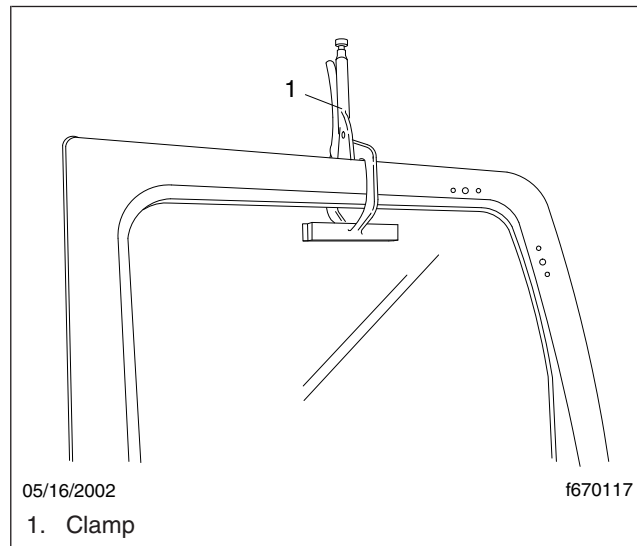

**Fig. 9, Window Clamping**

NOTE: The spacer is not required on the new regulator.

17. Remove the window regulator by removing the six mounting bolts. See [Fig. 10](#). Remove and discard the spacer as the top bolts are removed. Slide the window regulator out of the visibility window access hole in the inner door panel.

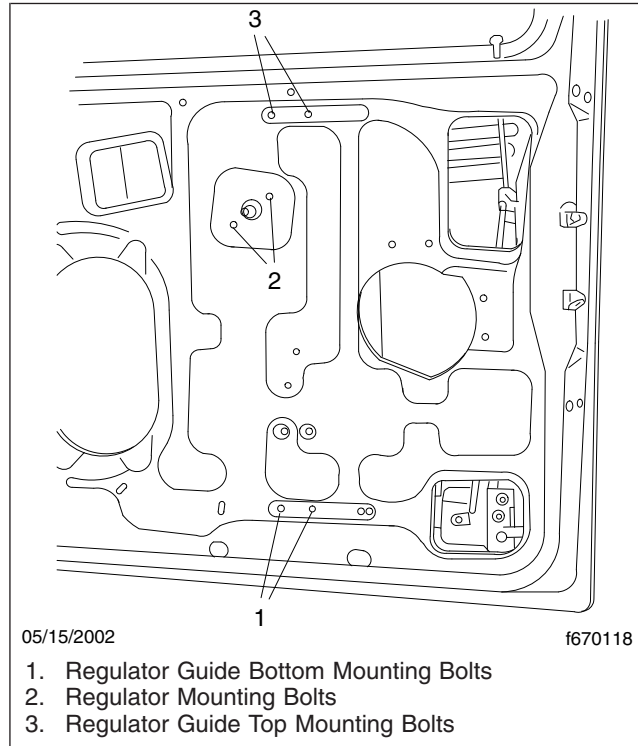

**Fig. 10, Regulator Mounting**

18. Remove the forward window channel by removing the mounting bolt(s)—there could be either one or two. See [Fig. 11](#). Slide the window guide out of the access hole in the door panel.



Constellation  
Heritage  
> 4700 Models  
4800 Models

> 4900 Models  
> 5700 Models  
5900 Models  
> 6900 Models

Western Star  
Service Bulletin

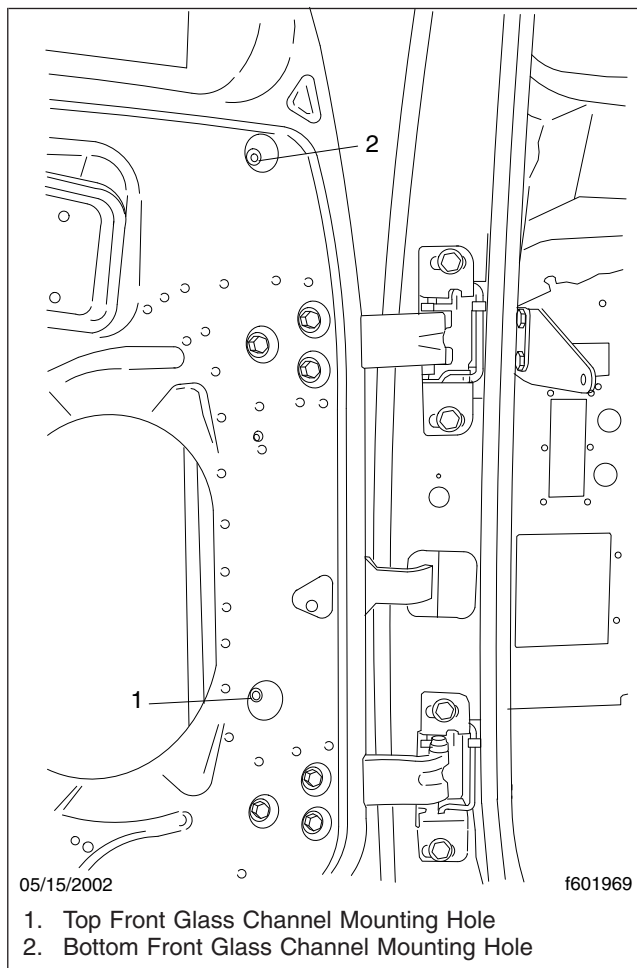

**Fig. 11, Glass Channel Mounting Holes**

19. Disconnect the door lock rod by prying it loose from the lock clip. Lift the door lock knob to pull the rod up and out of the way. See [Fig. 12](#).

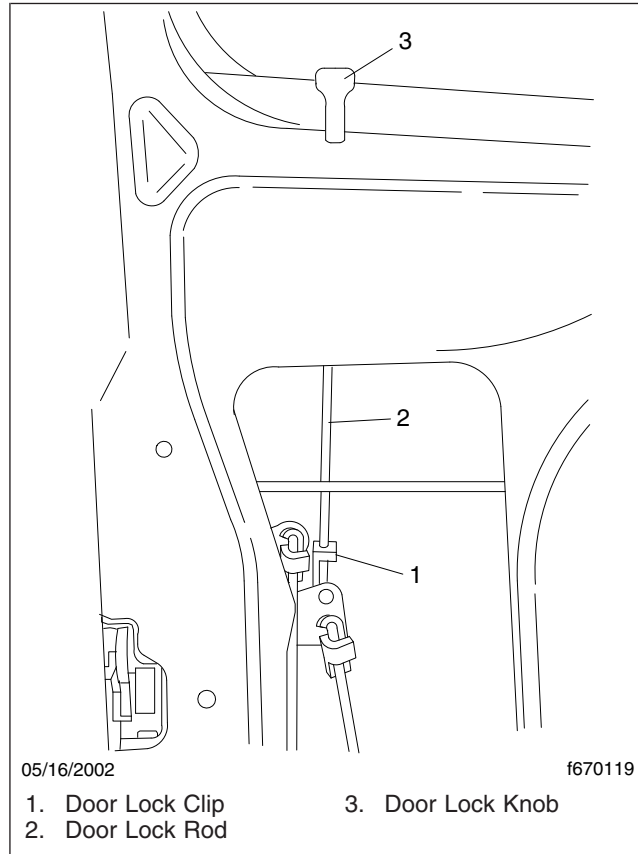

**Fig. 12, Door Lock Mechanism**

20. Remove the rear window channel by removing the mounting bolts—there could be either two or four. See [Fig. 13](#). Slide the window guide out of one of the access holes in the door.

Constellation  
Heritage  
> 4700 Models  
4800 Models

> 4900 Models  
> 5700 Models  
5900 Models  
> 6900 Models

Western Star  
Service Bulletin

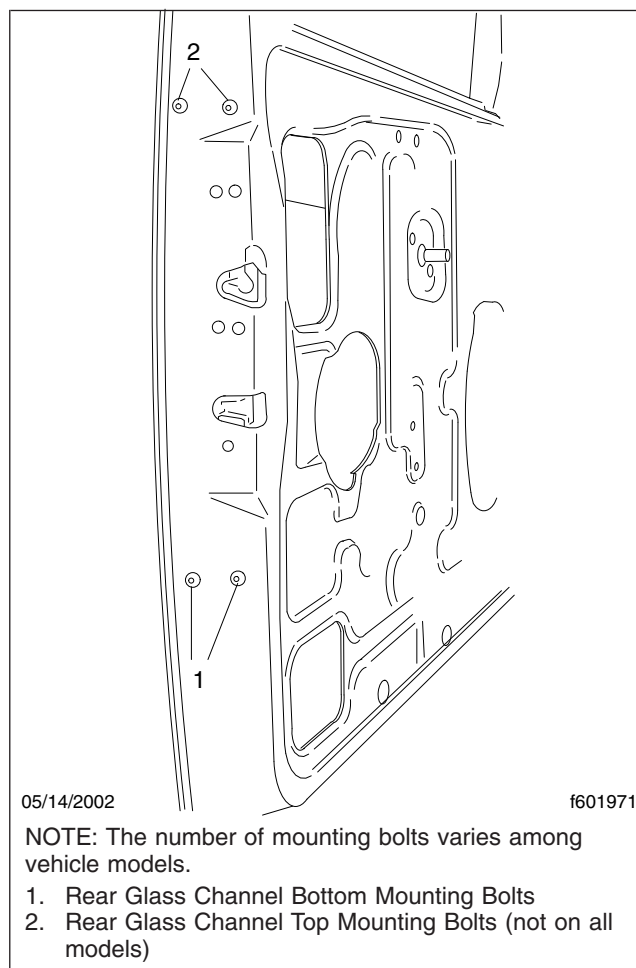

**Fig. 13, Rear Window Channel Mounting**

21. Hold the glass and remove the clamp. Lower the window part way down into the door. Rotate the window, lowering the front edge down. See [Fig. 14](#). Lift the window out of the door.

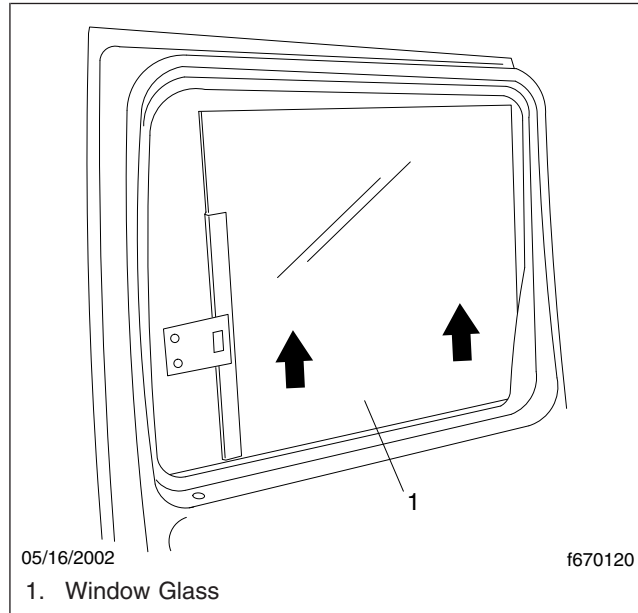

Fig. 14, Lifting the Door Window Out

## Window Glass and Regulator Replacement

1. Place the new window glass in the door, holding it up with a padded C-clamp over the door frame. See [Fig. 9](#).
2. Slide the rear window channel in through the access hole in the door, then attach it to the door with the mounting bolts. Torque to 60 lbf-in (678 N-cm). See [Fig. 13](#).
3. Attach the door lock rod to the lock clip. See [Fig. 12](#).
4. Slide the forward window channel in through the access hole in the door panel, then attach it to the door panel with the mounting screws. Torque to 60 lbf-in (678 N-cm). See [Fig. 11](#).
5. Insert the regulator in through visibility window access hole, then attach them to the door panel with the mounting bolts. Torque to 84 lbf-in (949 N-cm). See [Fig. 10](#).
6. Carefully release the glass from the C-clamp and lower it in place. The clip on the regulator will click into place through the hole in the glass at the bottom of the window.
7. Attach the upper mirror mounting brackets to the cab door. Torque to 26 lbf-ft (35 N-m). See [Fig. 7](#).
8. Install the top window run channel seals. See [Fig. 6](#).
9. Install the inner and outer window scraper seals. See [Fig. 5](#).

## Trim Panel Installation

1. Attach the vapor barrier.
2. Press the center upholstery panel into place on the door and attach with Christmas tree fasteners. See [Fig. 1](#).
3. Using short screws, install the lower trim panel. For fastener locations, see [Fig. 3](#). The remaining holes are used for the map pocket panel installation.

Constellation > 4900 Models  
 Heritage > 5700 Models  
 > 4700 Models 5900 Models  
 4800 Models > 6900 Models

4. Install the map pocket.
  - 4.1 Connect the courtesy lamp wiring to the door wiring harness. See [Fig. 2](#).
  - 4.2 Using long screws, attach the map pocket to the lower trim panel and the door.
5. Install the upper trim panel.
  - 5.1 Pull the wiring connectors through the switch opening on top of the panel. See [Fig. 15](#), Ref. A.

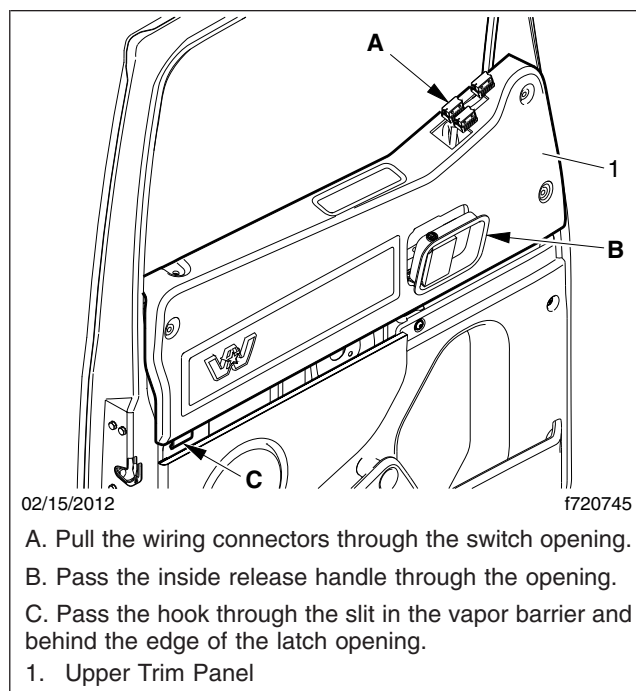

**Fig. 15, Upper Trim Panel Installation**

- 5.2 Set the upper panel against the door, rotating it to allow the interior release handle to pass through the opening. See [Fig. 15](#), Ref. B.
- 5.3 Position the hook at the lower rear corner of the panel behind the upholstery panel. Maneuver the hook through the slit in the vapor barrier and behind the edge of the latch opening. See [Fig. 15](#), Ref. C.
- 5.4 Lower the panel down over the lock rod. The bottom edge of the panel should cover the top edge of the center upholstery panel. Smooth the upholstery under the edge of the upper panel.
- 5.5 Install two short screws in the bottom of the pull cup and tighten securely.
- 5.6 Install one short screw in the lower forward corner and two long screws in the upper forward and rear corners. Tighten the screws securely.
6. Screw the lock rod knob onto the end of the lock rod.
7. Using four screws, install the interior release handle.
8. Install the manual window crank handle, if equipped.

### Western Star Service Bulletin

Constellation	> 4900 Models
Heritage	> 5700 Models
> 4700 Models	5900 Models
4800 Models	> 6900 Models

9. Connect the switches to the door wiring, then snap the switches into the panel openings. Make sure the switches are oriented properly.

### Warranty

Normal warranty applies. See [Table 3](#) for OWL VMRS codes and labor allowance information. Enter this service bulletin number in the Service Bulletin # field.

OWL VMRS Codes and Labor Allowance					
Primary Failed Part	Component Code	Cause Code	SRT Code	Description	Time: Hours
Regulator Assembly - Window, C	002-018-031	03	654-5001A	Regulator and Glass, Cable Style, Retrofit (SB72-008)	1.2

**Table 3, OWL VMRS Codes and Labor Allowance**