 <b>HYUNDAI</b> <b>Technical Service Bulletin</b>	<b>GROUP</b> <b>AUTOMATIC TRANSMISSION</b>	<b>NUMBER</b> <b>19-AT-024H</b>
	<b>DATE</b> <b>NOVEMBER 2019</b>	<b>MODEL</b> Accent (RB/HC), Azera (TG/HG), Elantra (UD/MD/JK/AD/ADa/GD/PD), Santa Fe (CM/AN/NC), Kona (OS) Sonata (YF/LF/DN8, Sonata YF HEV/LF HEV/PHEV), Tucson (LM/TL) Veloster (FS/JS)
<b>SUBJECT:</b> AUTOMATIC TRANSAXLE DIAGNOSIS (6-SPEED) INHIBITOR/RANGE SWITCH DTC P0705, P0706, P0707 & P0708		

***This TSB supersedes TSB 17-AT-005 to update the Service Procedure and applicable vehicles.***

**Description:** If you are servicing a vehicle with the DTC or symptoms listed below, refer to the **Service Procedure** to diagnose the condition.

- **Diagnostic trouble codes:**
  - P0705 - Range switch sensor circuit
  - P0706 - Range switch range/performance
  - P0707 - Range switch - open circuit
  - P0708 - Range switch - short circuit or multiple inputs
- **Symptoms:**
  - Malfunction Indicator Light (MIL) illuminated
  - 4<sup>th</sup> gear fail-safe
  - No gear indication in cluster
  - Intermittent no engine crank/no start in “P” or “N” with or without MIL or DTC.

**Applicable Vehicles:**

2012~17	Accent (RB)
2018~	Accent (HC)
2011	Azera (TG)
2012~17	Azera (HG)
2011~16	Elantra (MD/UD)
2017~	Elantra (AD/ADa) 2.0L
2013~14	Elantra Coupe (JK)
2013~17	Elantra GT (GD)
2018~	Elantra GT (PD) 2.0L
2018~	Kona (OS) 2.0L
2013~18	Santa Fe Sport (AN)
2013~19	Santa Fe (NC)
2019~	Santa Fe (TMa)
2011~14	Sonata (YF)
2015~19	Sonata (LF) 2.0T/2.4L
2020~	Sonata (DN8)
2011~15	Sonata Hybrid (YF HEV)
2016~19	Sonata Hybrid/Plug-in Hybrid (LF HEV/PHEV)
2010~15	Tucson (LM)
2016~	Tucson (TL) 2.0L
2013~15	Veloster Turbo (FS)
2019~	Veloster (JS) 2.0L

## PARTS INFORMATION:

MY	MODEL	PNC CODE	PART NUMBER
2012~17	Accent (RB)	45956B	42700-*****
2018~	Accent (HC)	45956B	42700-*****
2011	Azera (TG)	45956B	42700-*****
2012~17	Azera (HG)	45956B	42700-*****
2011~16	Elantra (MD/UD)	45956B	42700-*****
2017~	Elantra (AD/ADa) 2.0L	45956B	42700-*****
2013~14	Elantra Coupe (JK)	45956B	42700-*****
2013~17	Elantra GT (GD)	45956B	42700-*****
2018~	Elantra GT (PD) 2.0L	45956B	42700-*****
2018~	Kona (OS) 2.0L	45956B	42700-*****
2013~18	Santa Fe Sport (AN)	45956B	42700-*****
2013~19	Santa Fe (NC)	45956B	42700-*****
2019~	Santa Fe (TMa)	42700E	42700-*****
2011~14	Sonata (YF)	45956B	42700-*****
2015~17	Sonata (LF) 2.0T	45956B	42700-*****
2018~19	Sonata (LF) 2.0T	42700E	42700-*****
2015~19	Sonata (LF) 2.4L	45956B	42700-*****
2020~	Sonata (DN8)	42700E	42700-*****
2011~15	Sonata Hybrid (YF HEV)	45956B	42700-*****
2016~19	Sonata Hybrid (LF HEV/PHEV)	45956B	42700-*****
2010~15	Tucson (LM)	45956B	42700-*****
2016~	Tucson (TL) 2.0L	45956B	42700-*****
2013~15	Veloster Turbo (FS)	45956B	42700-*****
2019~	Veloster (JS) 2.0L	45956B	42700-*****

**WARRANTY INFORMATION:**

MY	MODEL	OP CODE	OPERATION	OP TIME	CAUSAL PART
2012~	Accent (RB)	42700R00	Replace inhibitor switch/ range switch/ position sensor	Refer to WEBLTS for current LTS time	See Parts Information table on Page 2
2018~	Accent (HC)				
2011	Azera (TG)				
2012~17	Azera (HG)				
2011~16	Elantra (MD/UD)				
2017~	Elantra (AD/ADa) 2.0L				
2013~14	Elantra Coupe (JK)				
2013~17	Elantra GT (GD)				
2018~	Elantra GT (PD) 2.0L				
2018~	Kona (OS) 2.0L				
2013~18	Santa Fe Sport (AN)				
2013~19	Santa Fe (NC)				
2019~	Santa Fe (TMa)				
2011~14	Sonata (YF)				
2015~19	Sonata (LF) 2.0T/2.4L				
2011~ 15	Sonata (YF HEV)				
2016~19	Sonata (LF HEV/PHEV)				
2020~	Sonata (DN8)				
2010~15	Tucson (LM)				
2016~	Tucson (TL) 2.0L				
2013~15	Veloster Turbo (FS)				
2019~	Veloster (JS) 2.0L				
All		42700RQ0	GDS		

## SERVICE PROCEDURE:

1. Turn the ignition key to the ON position or push the Start/Stop Button two times without depressing the brake pedal.
2. Attach a GDS and check for DTC in the “Automatic Transaxle” menu. **Record the DTC and description.** Delete the DTC.
3. Select **Data Analysis, AT** menu and **Shift Lever Switch**. Move the shift lever through all gears (P, R, N and D) and monitor the Shift Lever Switch.

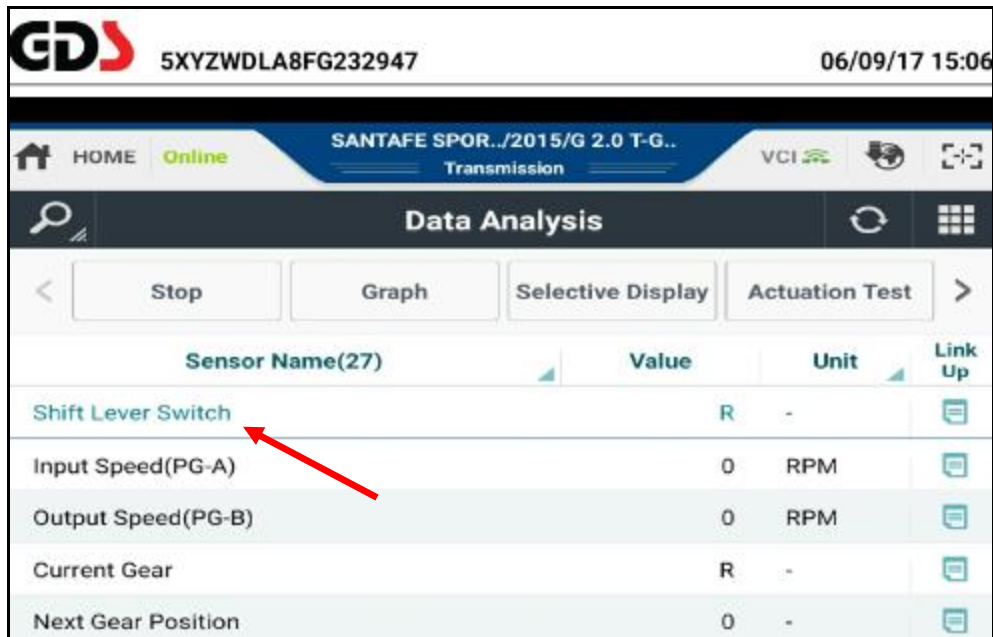

The screenshot shows the GDS Data Analysis interface. At the top, the GDS logo is on the left, the vehicle ID '5XYZWDLA8FG232947' is in the center, and the date/time '06/09/17 15:06' is on the right. Below this is a navigation bar with 'HOME', 'Online', and 'SANTAFE SPOR../2015/G 2.0 T-G..' with 'Transmission' selected. The main title is 'Data Analysis'. Below the title are four buttons: 'Stop', 'Graph', 'Selective Display', and 'Actuation Test'. A table below displays sensor data:

Sensor Name(27)	Value	Unit	Link Up
Shift Lever Switch	R	-	
Input Speed(PG-A)	0	RPM	
Output Speed(PG-B)	0	RPM	
Current Gear	R	-	
Next Gear Position	0	-	

A red arrow points to the 'Shift Lever Switch' row in the table.

4. If the Shift Lever Switch shows:
  - The correct shift lever position, the wiring **currently** has no open/short circuits. Go to Step 6.
  - Does not show the correct shift lever position, go to Step 5.
5. Visually check the wiring harness between the ECU and inhibitor switch for a damaged wire or open circuit/short circuit to ground. Check for a damaged pin or pin not fully inserted into the connector.
  - If damage is found, repair or replace the control wiring and drive the vehicle to confirm the repair.
  - If no damage or open/short circuit is found, go to Step 6.

6. Turn the ignition switch to the ON position and place the shift lever in P and N. Confirm the indicator lights in the dash cluster show the correct gear in P and N.
  - If P and N are displayed, go to Step 7.
  - If P or N is not displayed, go to Steps 9 and 15 and check the alignment of the inhibitor switch. Adjust as necessary
  - If P and N are not displayed after adjustment, go to Step 7.

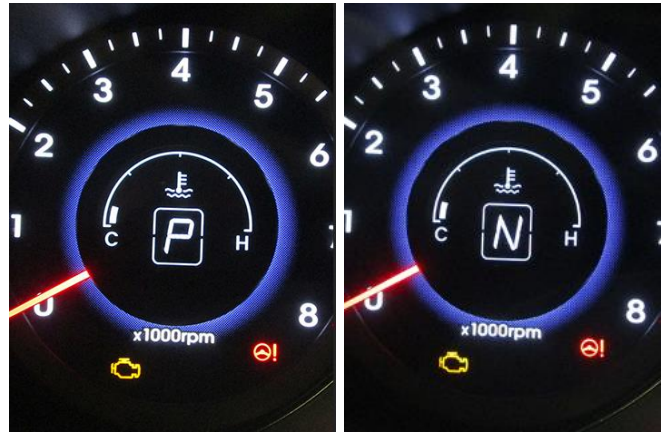

7. Check the TCU and TCU2 fuse in the junction box in the engine compartment:
  - Check the fuse for an open circuit.
  - Check the fuse for correct capacity.
  - Check the fuse holder for a tight fit.
  - Check for loose or damaged wires.



If damage or intermittent open circuit is found, repair or replace the junction box and front harness.

If no damage or intermittent open circuit is found, go to Step 8.

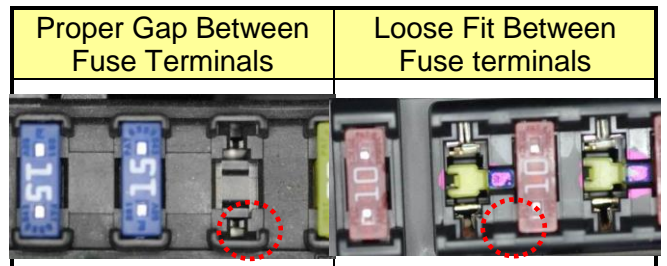

8. Check the rear combination lamp ground for tightness.

**Torque: 7~9 lb-ft (1.0~1.2kgf.m)**

Turn the ignition and headlights on. Use a DVOM to check the voltage drop between the combination lamp wiring terminal and ground.

**Specification: Less than 0.2 V.**

- If more than 0.2V, clean the terminal and bolt threads and tighten the bolt.
- If less than 0.2V, go to Step 9.

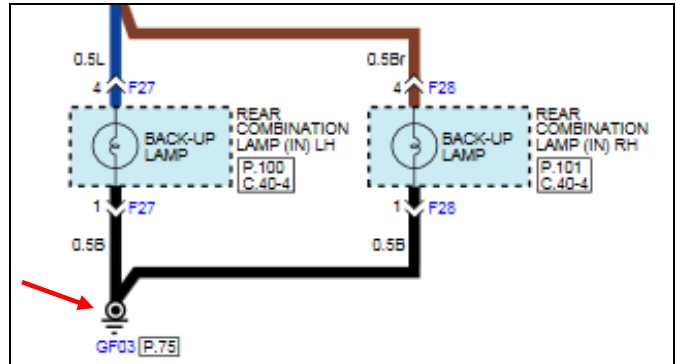



9. Apply the parking brake. Move the shift lever to the “N” position.

Turn the ignition switch to the **OFF** position.



10. Remove the air duct and air cleaner to access the inhibitor switch.

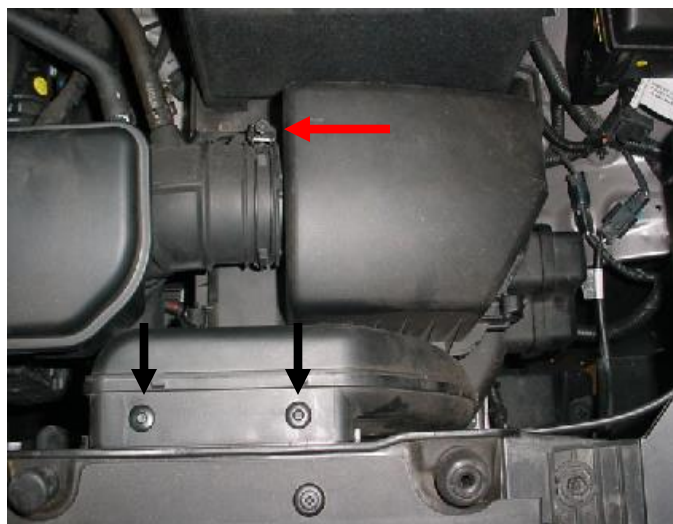

11. Remove the battery.

**NOTICE**

Record the preset radio stations and reset after repairs are completed.



12. Remove 2 bolts to the air cleaner.

Remove 4 bolts to the battery tray and remove the battery tray.

**Torque: 7~9 lb-ft (1.0~1.2 kgf.m/10~12 N.m)**

Move the battery tray aside to gain access to the inhibitor switch.

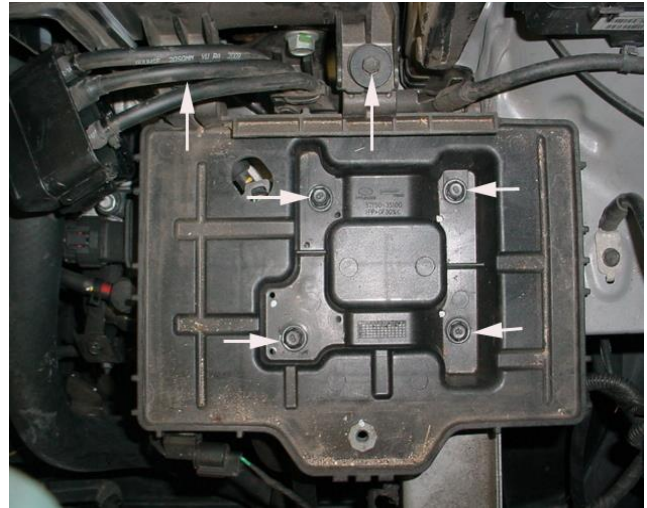

13. Disconnect the inhibitor switch connector (A)

Remove the shift cable mounting nut (B).

Remove the nut (C) and washer and remove the manual control lever (D).

**CAUTION**

Do not use an impact gun.

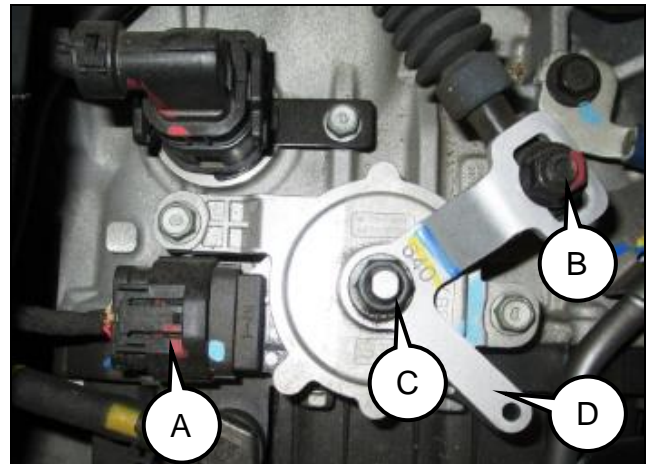

14. Remove 2 mounting bolts (E) and remove the inhibitor switch assembly.

Install the new inhibitor switch assembly to the transaxle and tighten the mounting bolts.

**Torque: 7~9 lb-ft (1.0~1.2 kgf.m/10~12 N.m)**

Reconnect the inhibitor switch connector (A).

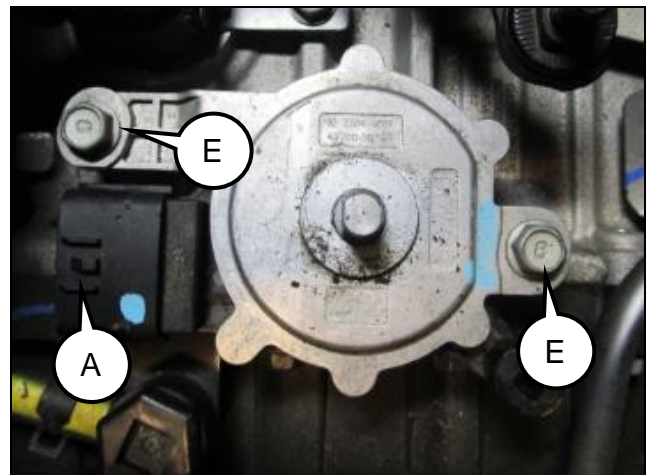

15. Install the manual control lever, washer and nut to the new inhibitor switch.

Insert SST **09480-A3800** guide pin or **5mm** bolt in the alignment hole.

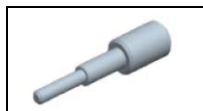

**CAUTION**

Do not use an impact gun.

Tighten the nut to specification.

**Torque: 13~18 lb-ft (1.8~2.5 kgf.m/18~24 n.m)**

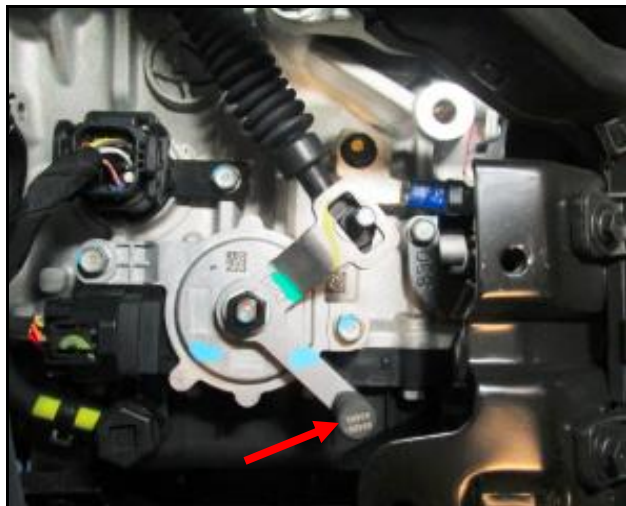

16. Confirm the shift lever is in the **N** position.

Install the shift cable nut and tighten the nut (B) to specification.

**Torque: 6~9 lb-ft (0.8~1.2 kgf.m, 8~12 N.m)**

Remove the SST or 5mm bolt from the alignment hole.

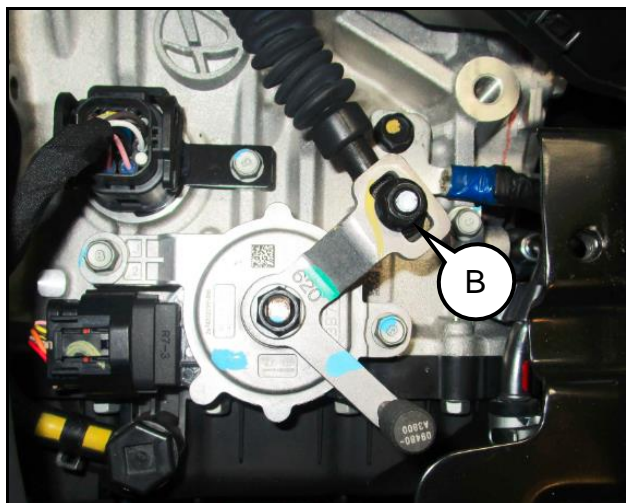

17. Reinstall all the removed parts in reverse order of removal.

Reset the radio stations.

18. Clear the DTC and test drive the vehicle for two drive cycles (two key-on to key-off driving cycles). If the DTC:

- Does not occur again, return the vehicle to the customer.
- If the DTC occurs again, repair or replace the control wiring between the ECU and inhibitor switch. If the DTC occurs again after repairing or replacing the control wiring, replace the ECU.

19. Clear DTC in the BlueLink system per instructions of TSB 19-EE-010H, if applicable.