



# Service Bulletin

Bulletin No.: 19-NA-271

Date: December, 2019

## TECHNICAL

**Subject:** Accessory Rear Seat Infotainment (RSI) Shuts Off, Coinciding with Closing of Door or Liftgate.

**Attention:** This bulletin will only correct the specific condition/issues as described, so before proceeding, ensure the problem identified is as described below. If not, refer to RSI diagnostic information, located in the accessory installation manual in SI.

Brand:	Model:	Model Year:		VIN:		Engine:	Transmission:
		from	to	from	to		
Buick	Enclave	2018	2020			All	All
Chevrolet	Traverse						

<b>Involved Region or Country</b>	North America, N.A. Export Regions
<b>Additional Options (RPOs)</b>	
<b>Condition</b>	<p>Some customers may comment that the RSI screens power off, coinciding with the closing of a door or liftgate.</p> <p>Before proceeding, ensure that the problem is as described: RSI screens powered on, and vehicle is in mode ON/ RUN/ START (green indicator light). The screens will power off when the last door or liftgate is closed.</p> <p>⇒ With the transmitter <b>inside</b> the vehicle, the issue will be intermittent, usually more prone as the transmitter is closer to the wireless phone charger.</p> <p>⇒ When the transmitter is <b>outside</b> the vehicle, the issue will occur every time the liftgate or any doors close.</p>
<b>Cause</b>	The cause of the condition may be that the RSI is powered by the iRAP feed. When the vehicle's PEPs module searches for the key transmitter, it momentarily powers down the iRAP feed to clear possible radio frequency interference. This causes the RSI screens to power off.

## Correction



5441085

Following the steps in the Service Procedure below, install a new Audio Player Wiring Harness Assembly (shown packaged above) to the RSI power feed. This harness assembly will add a second power feed (ignition) to the RSI kit to supply power to the RSI, while the iRAP feed is temporarily not available.

## Service Procedure



5441086

1. Before beginning installation, verify that the diode orientation is correct in the service jumper harness.
  - 1.1. Ensure that both diodes are pointing toward the single red wire.
  - 1.2. Close both diode covers.

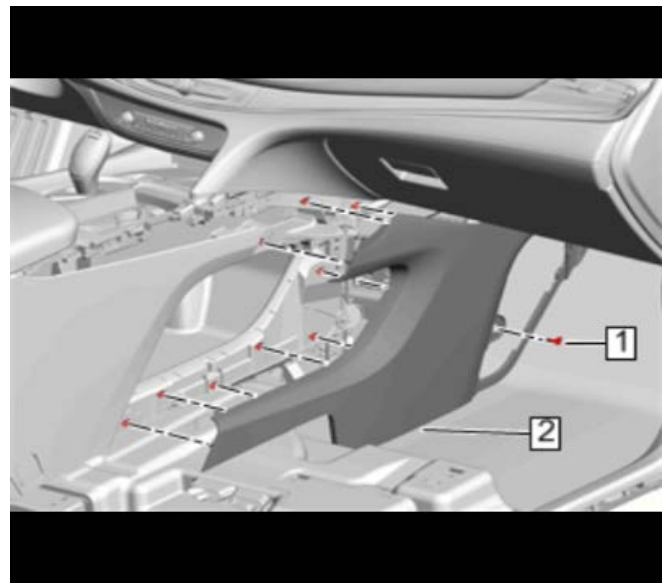

5441087

**Note:** A number of the graphics in the repair procedure show the passenger front seat loosened and tipped rearward, *for illustration purposes only*. Front seat removal is NOT required, and the necessary access can be gained by moving the seat to the far rearward position.

2. Remove the right side front floor console extension panel (2). Refer to *Front Floor Console Extension Panel Replacement - Right Side, in SI*.



5441088

- 3. Locate the power feed to the RSI kit; this will be the red wire coming from the fuse panel and feeding the rear seat monitors, which contains an in-line fuse holder (circled), .

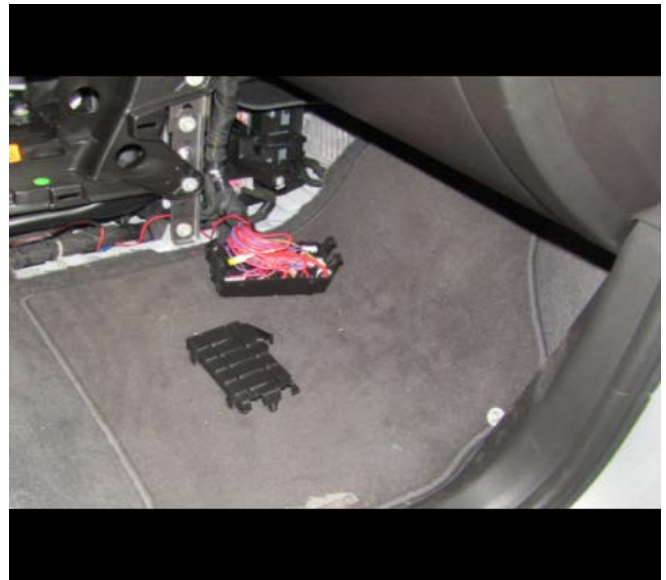

5441092

- 4.1. Remove the fuse panel from the mounting bracket, then remove the rear cover to expose the T- tap connection for the RSI power feed.

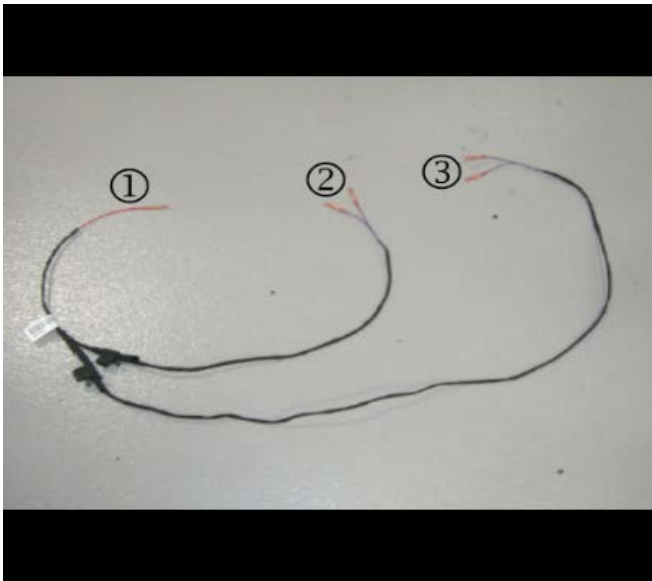

5441090

- 4. The new harness assembly will be spliced into RSI monitor power wire (1), the RSI power feed (2) AND into the passenger vented seat wiring power feed (3).



5441095

- 4.2. Remove the T- tap connection (1) for the RSI power wire, from the wiring bundle.



5441096

4.3. Cut the T-tap crimp connection off the red RSI power wire.

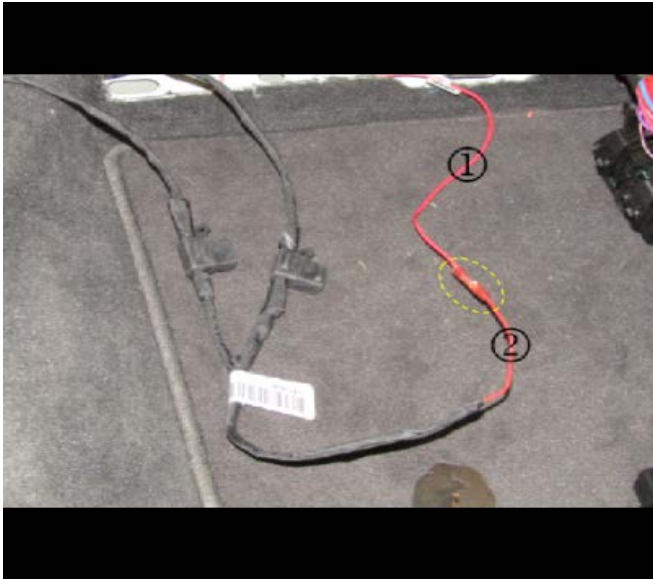

5441097

4.4. Splice the RSI power wire (1) to the single red wire of the new jumper harness (2).

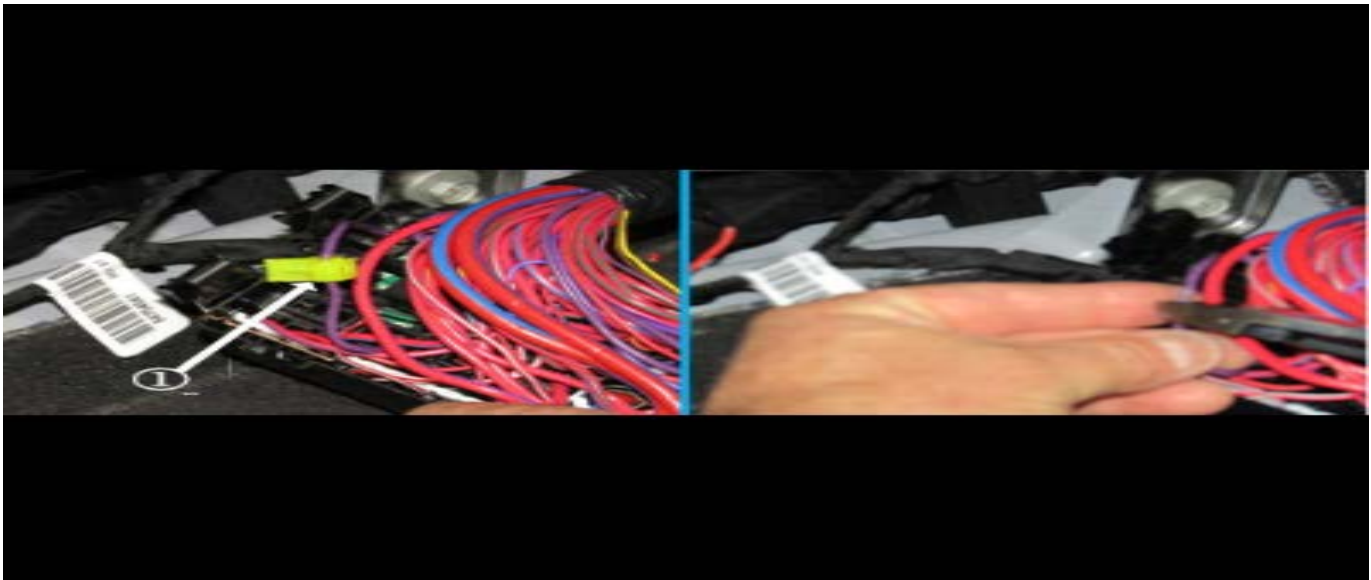

5441098

4.5. Locate the splice of the T- tap on the vehicle wiring harness, remove tap from wire and (1), cut the wire.

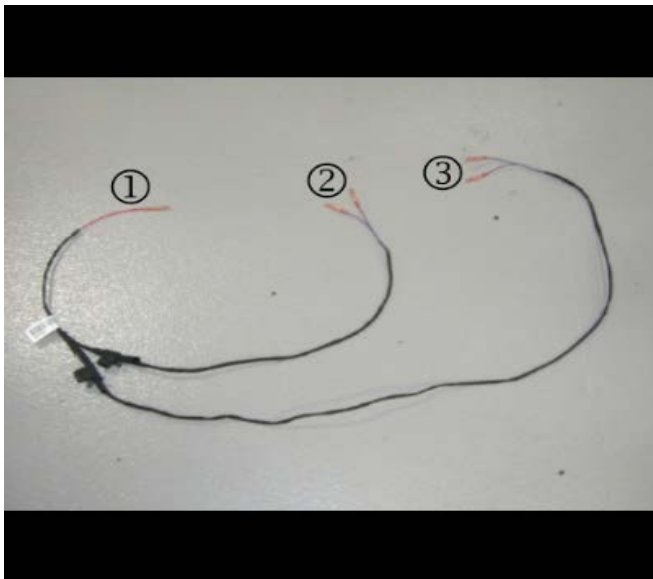

5441090

**Note:** The new jumper harness has two main leads with 2 wires per lead (2) and (3). The shorter lead (2) will be spliced first.

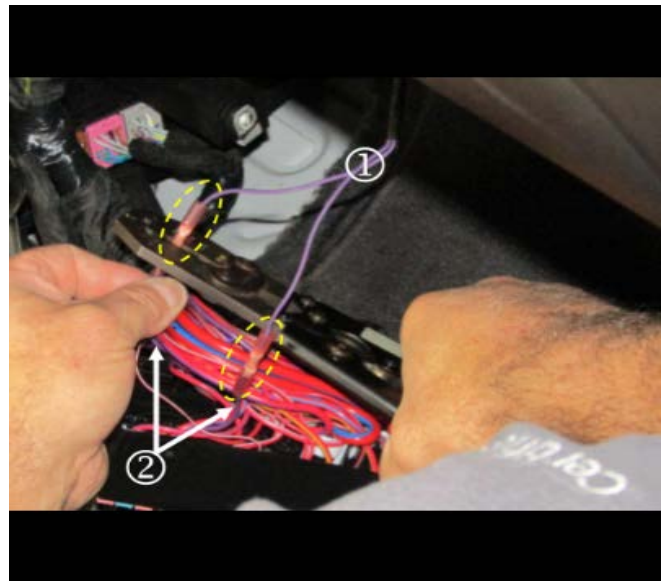

5441100

4.6. Splice the two wires of the jumper harness short lead (1) into the wire that was cut (2). Wiring orientation does not matter.



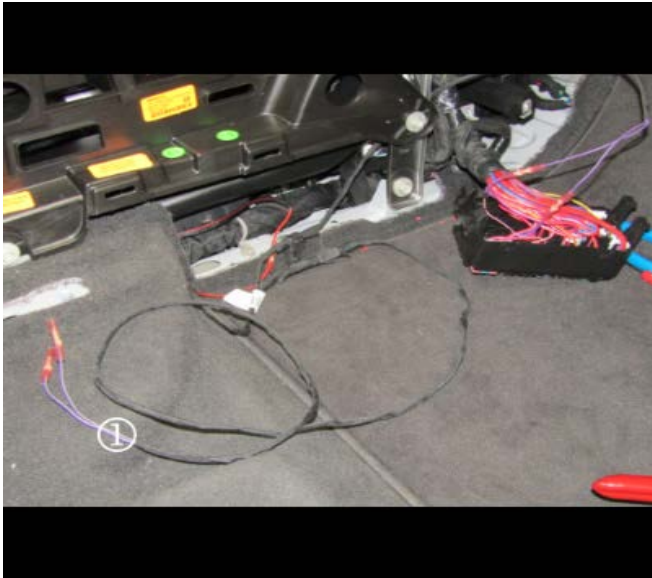

5441101

- 4.7. The remaining long lead (1) will be spliced into the passenger side vented seat harness, located under the passenger seat. Route this wire, along with the RSI kit wiring under the seat track, to the passenger seat.



5441104

- 4.9. Cut the Violet/Black wire coming from pin 1, far enough from the connector to allow for the splice.

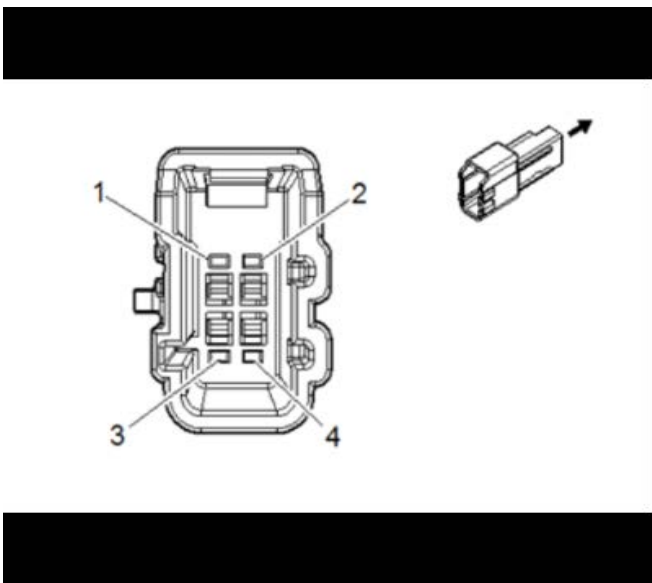

5441102

- 4.8. Under the passenger seat, locate the connector **M73B Seat Blower Motor - Passenger Back (KU9)**. Refer to, *Document ID: 5086459* in SI, for further information.

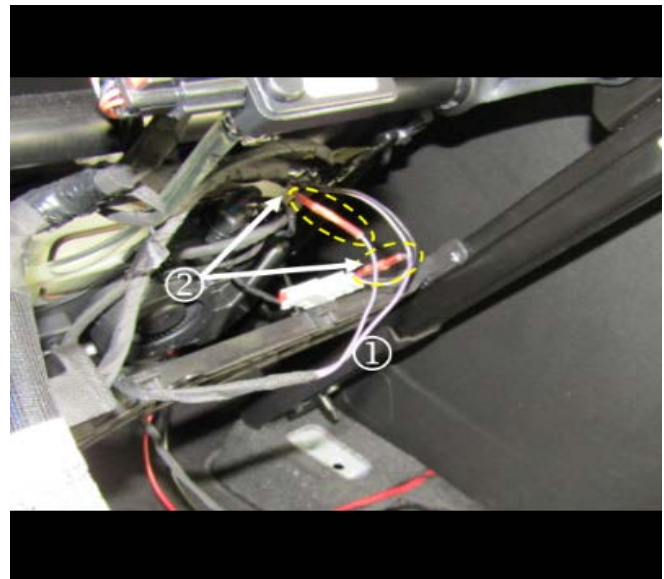

5441105

- 4.10. Splice the two wires of the jumper harness long lead (1) into the wire that was cut (2). Wiring orientation does not matter.



5441106

- 4.11. Secure wiring to the seat, being sure to allow for full seat travel.

5. Test system for proper operation:

**Note:** Vehicle must be running or in service mode to test for proper operation. **Testing cannot be done in accessory mode.**

- 5.1. Place vehicle into service mode. With brake pedal NOT applied, press and hold ENGINE START/STOP, for more than five seconds (green indicator light).
- 5.2. Turn the RSI screens on and wait for them to load screen.
- 5.3. While keeping the transmitter/fob OUTSIDE the vehicle, shut all doors, including the liftgate.
  - If the screens Do NOT power off, the system is wired correctly.
  - If the screens DO power off, recheck the wiring and diode orientation as referenced.
6. Verify the passenger vented seat operates correctly.



5441107

**Note:** Avoid pinching any of the wiring or running the wiring close to any sharp edges under the console. To secure from rattling, finish by retaining with tie-straps.

7. To ensure a clean installation, tape up and secure all wiring. Reinstall the fuse panel rear cover and reattach the panel to bracket.

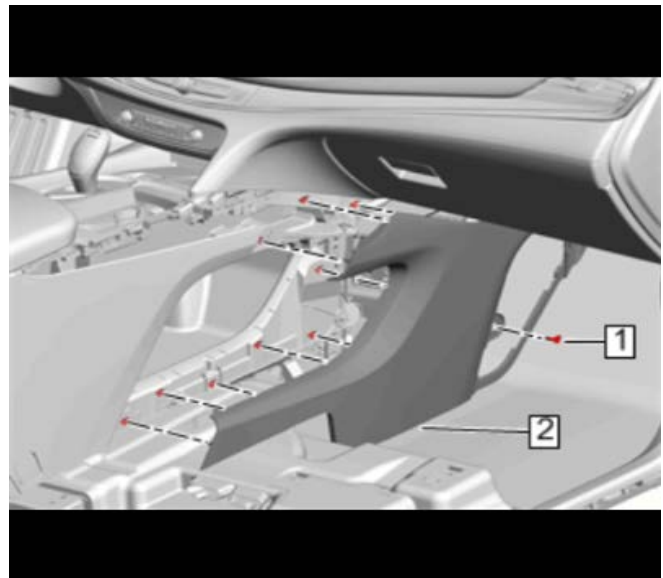

5441087

8. Reinstall the right side front floor console extension panel (2). Refer to *Front Floor Console Extension Panel Replacement - Right Side, in SI*.

## Parts Information

The Audio Player Wiring Harness Assembly can be obtained from the Warranty Parts Center (WPC) using the TSP Dealer Request Form located on Global Connect<Service Department<Service Forms Application<General Information tab<TSP Dealer Request Form. Instructions for submitting are on the form. Request **WPC843**.

## Warranty Information

For vehicles repaired under the Bumper-to-Bumper coverage (Canada Base Warranty coverage), use the following labor operation. Reference the Applicable Warranties section of Investigate Vehicle History (IVH) for coverage information.

Labor Operation	Description	Labor Time
0580458*	RSI Audio Player Wiring Harness Assembly Installation	0.5 hr
*This is a unique Labor Operation for Bulletin use only.		

## Additional SI Keywords

Accessory, Bluray, CD, display, DVD, Entertainment, Interruptible, iRAP, Monitor, Power, Retained, RAP, Screen

Version	1
Modified	Released November 26, 2019.

