



Technical Journal

TITLE:

Drive-E: Low oil level message in Driver Information Module (DIM)

REF NO: TJ 31216.5.0	ISSUING DEPARTMENT: Technical Service	CAR MARKET: United States and Canada	
PARTNER: 3 US 7510 Volvo Car USA		ISSUE DATE: 2019-09-30	STATUS DATE: 2019-10-15
FUNC GROUP: 2200	FUNC DESC: Lubricating and oil system	Page 1 of 11	

“Right first time in Time”

Attachment

File Name	File Size
TJI-492577_1_1_7 -us.pdf	0.1832 MB

Vehicle Type

Type	Eng	Eng Desc	Sales	Body	Gear	Steer	Model Year	Plant	Chassis range	Struc Week Range
1XX	26						2014-2016		0000001-9999999	201346-201604
1XX	40						2014-2016		0000001-9999999	201346-201604
1XX	49						2014-2016		0000001-9999999	201346-201604
256	10						2015-2016		0000001-0999999	201346-201604
256	A2						2015-2016	21	0000001-9999999	201505-201604

CSC Customer Symptom Codes

Code	Description
AZ	Lubrication and oil system/Excessive oil consumption
BU	Lubrication and oil system/Incorrect fluid level
7G	Text window and warning symbol/Yellow symbol and text message
EA	Text window and warning symbol/Red symbol and text message

VST Operation Number

VST Operation Number	Description
98623-2	Pistons replace acc. to TJ31216



DTC Diagnostic Trouble Codes

Rows beginning with * are modified

Note! If using a printed copy of this Technical Journal, first check for the latest online version.

Text

DESCRIPTION:

* Instruction updated with scratch check with the finger nail.

If the engine may still have a high oil consumption despite following TJ30739, TJ30087 or TJ29953, follow the actions described under "Service".

(indicated TJ's may be market related and are not visible if not applicable)

SERVICE:

From engine serial number: 1501327, engines have been modified from engine factory.

For service: Change to new pistons + piston rings according the attached service method.

VEHICLE REPORT:

Yes, please submit a Vehicle Report if the service solution described in this TJ has no effect. Use concern area "Vehicle Report" and sub concern area "Support not needed", use function group 2200.

To view TJ attachment continue to next page. This TJ has one attachment.



Title	Piston	Page	1 (9)
Action	Replacement	Operation number:	98623-2

Issue	Date	Reason
6	2019-06	Text change
5	2019-05	Technical content change
4	2017-11	Technical content change
3	2017-07	Change in Affected Vehicles
2	2017-06	Change in Affected Vehicles
1	2016-02	First issue

Affected vehicles

Model year	Model	Engine
2014, 2015, 2016	S60 (11-18)	B4204T10, T11, T12, T15, T37, T9
2016	S60L	B4204T11
2014, 2015, 2016	S80 (07-)	B4204T11, T12, T15
2015, 2016	V40 (13-)	B4204T11, T15, T19, T37, T38
2014, 2015, 2016	V60 (-18)	B4204T11, T12, T15, T37, T9
2014, 2015, 2016	V70 (08-)	B4204T11, T19
2014, 2015, 2016	XC60 (-17)	B4204T10, T11, T12, T15, T9
2016	XC90 (16-)	B4204T27

Materials

Materials	Qty.	Part No.	Notes
Engine oil	0.3		
Piston kit	4.0	31493184	B4204T11/12/15;
Piston kit	4.0	31493186	B4204T9/B4204T10;
Piston kit	4.0	31493188	B4204T19/37/38;
Piston kit	4.0	31493190	B4154T4/5;

Special tools

Description	Part No.
Holder (remov.piston/connecting rod) B 200-B 6304	999 5746

Equipment

Designation	Part No.
Piston ring pliers	
Piston ring compressor	

Removal

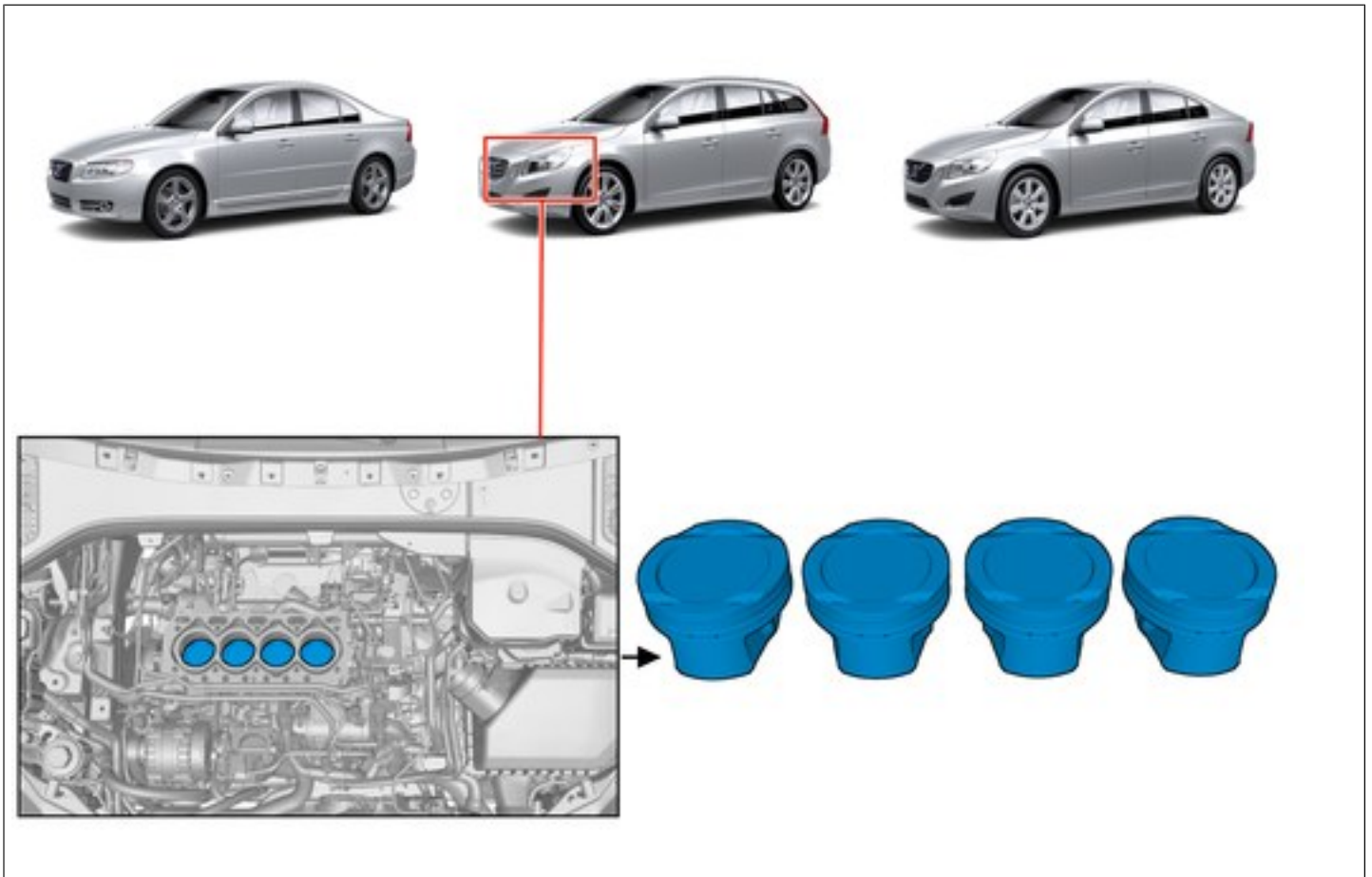

Color symbols

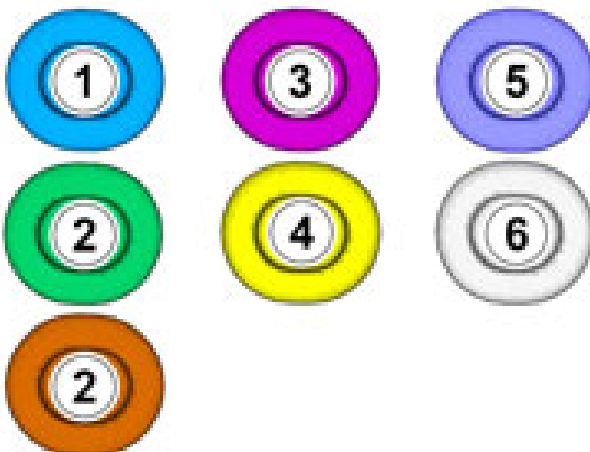

Note! This colour chart displays (in colour print and electronic version) the importance of the different colours used in the images of the method steps.

- 1 . Used for focused component, the component with which you will do something.
- 2 . Used as extra colors when you need to show or differentiate additional parts.
- 3 . Used for attachments that are to be removed/installed. May be screws, clips, connectors, etc.
- 4 . Used when the component is not fully removed from the vehicle but only hung to the side.
- 5 . Used for standard tools and special tools.
- 6 . Used as background color for vehicle components.

Remove the cylinder head , refer to:
Removal, replacement and installation
2 - Engine with mountings and equipment
21 - Engine
211 - cylinder head

Check

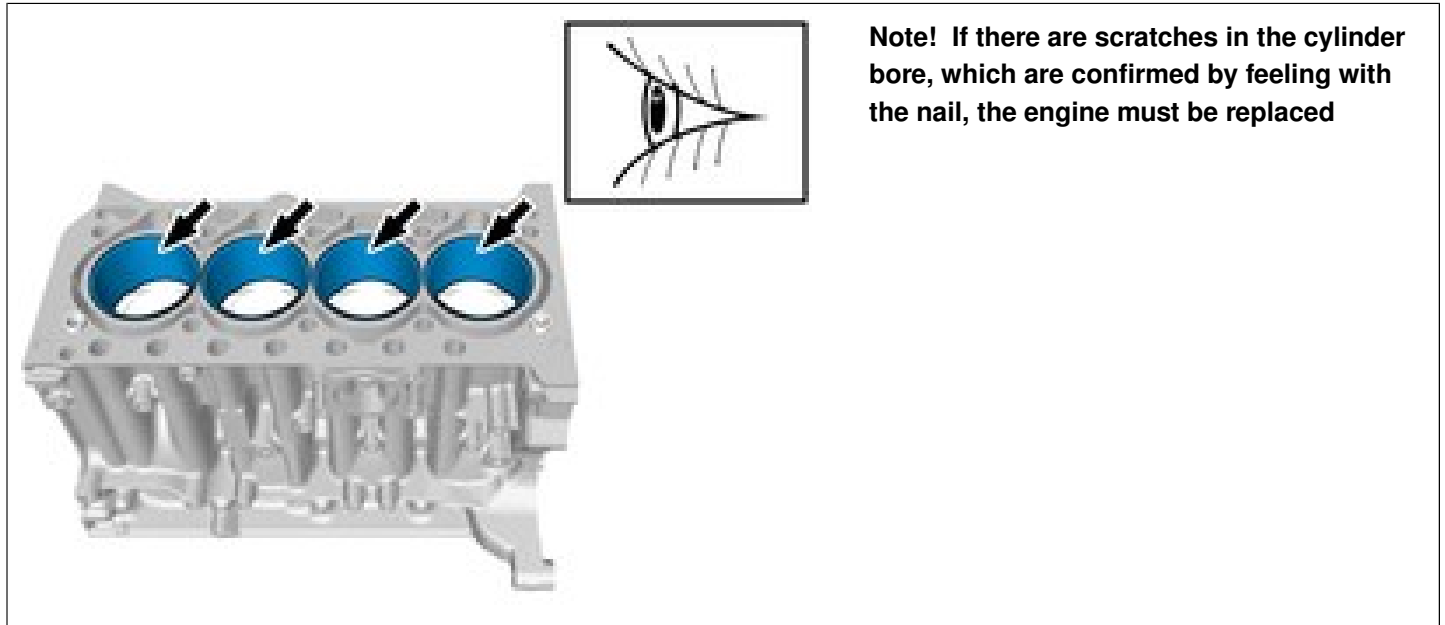

Removal

Remove balance shaft unit , refer to:
Removal, replacement and installation
2 - Engine with mountings and equipment
21 - Engine
215 - transmission

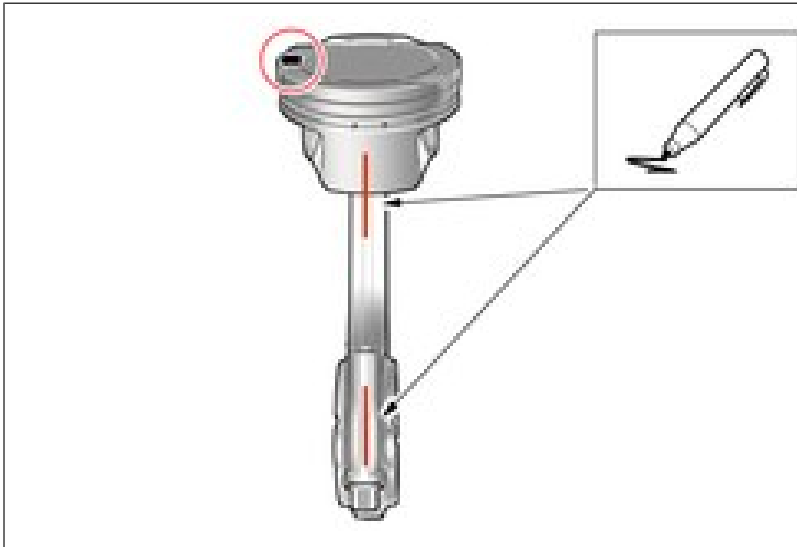

Caution! Note the position of the component before removal.

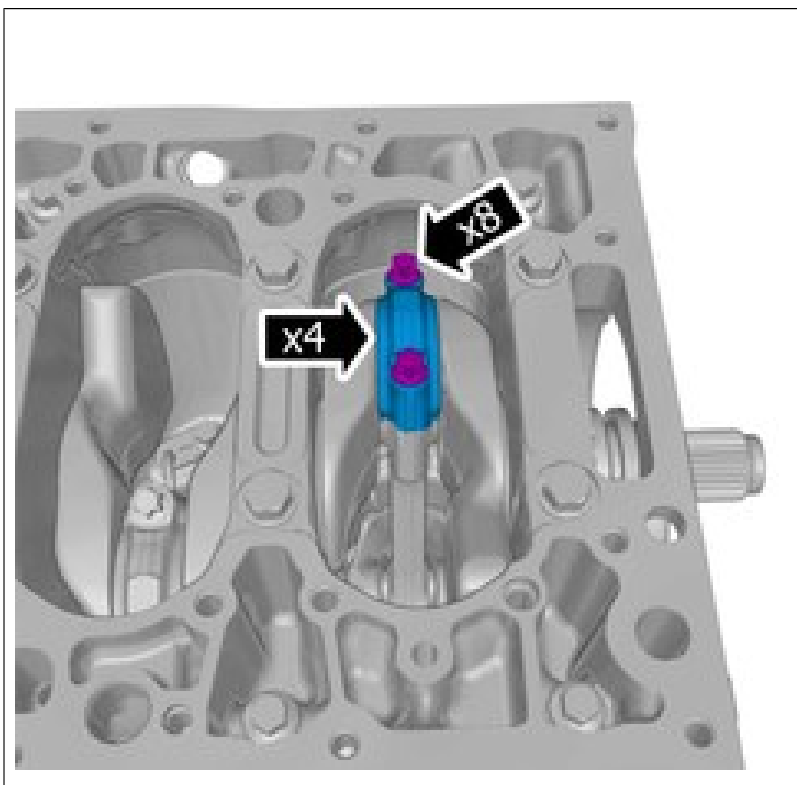

Caution! Take extra care when handling the components.

Remove the screws.
Remove the marked part.

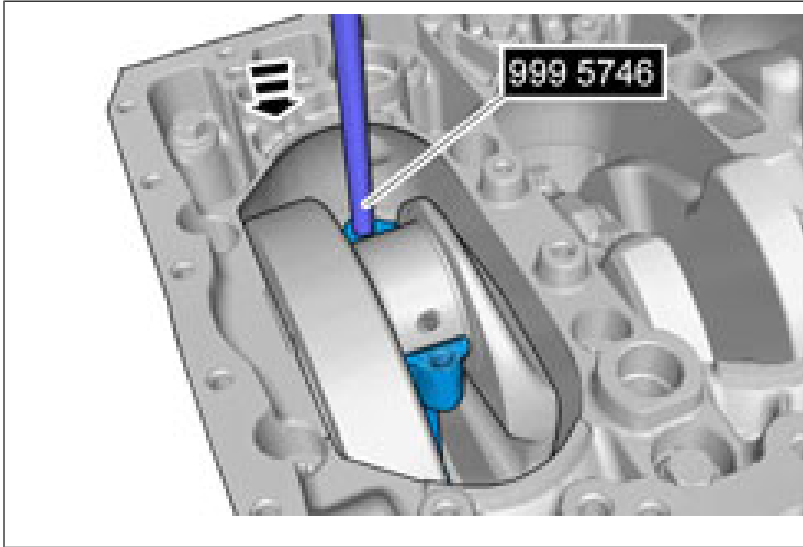

Caution! Take extra care when handling the components.

Special Tool: T9995746, Holder (remov.piston/ connecting rod) B 200-B 6304

Remove the marked part.

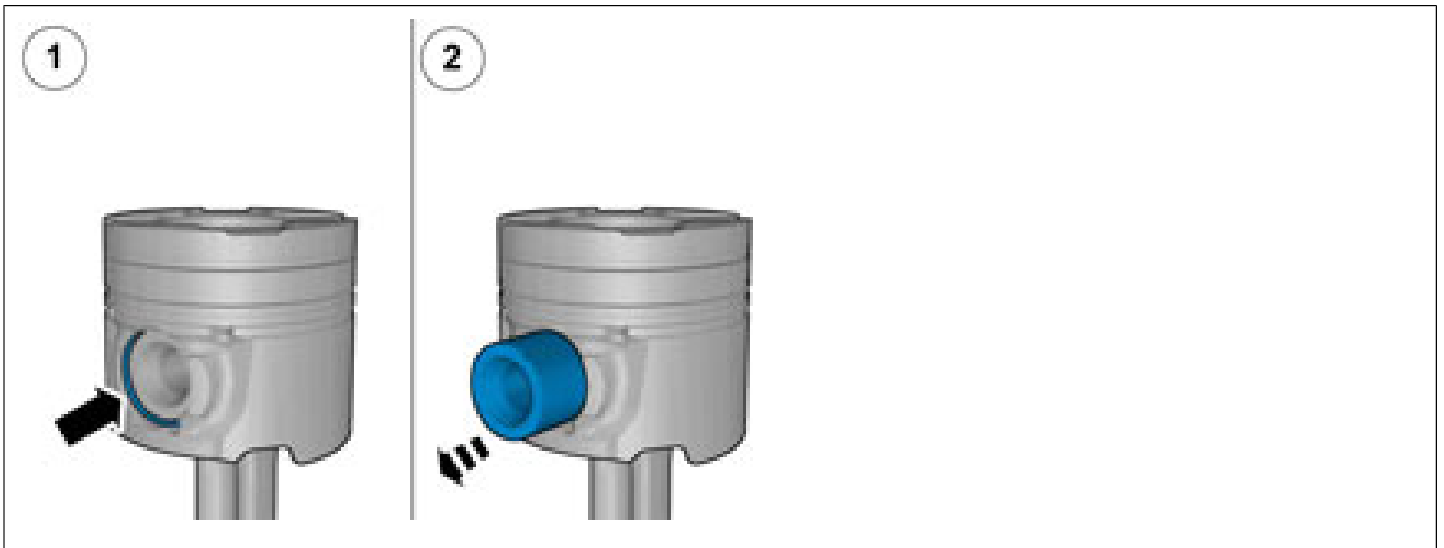

Installation

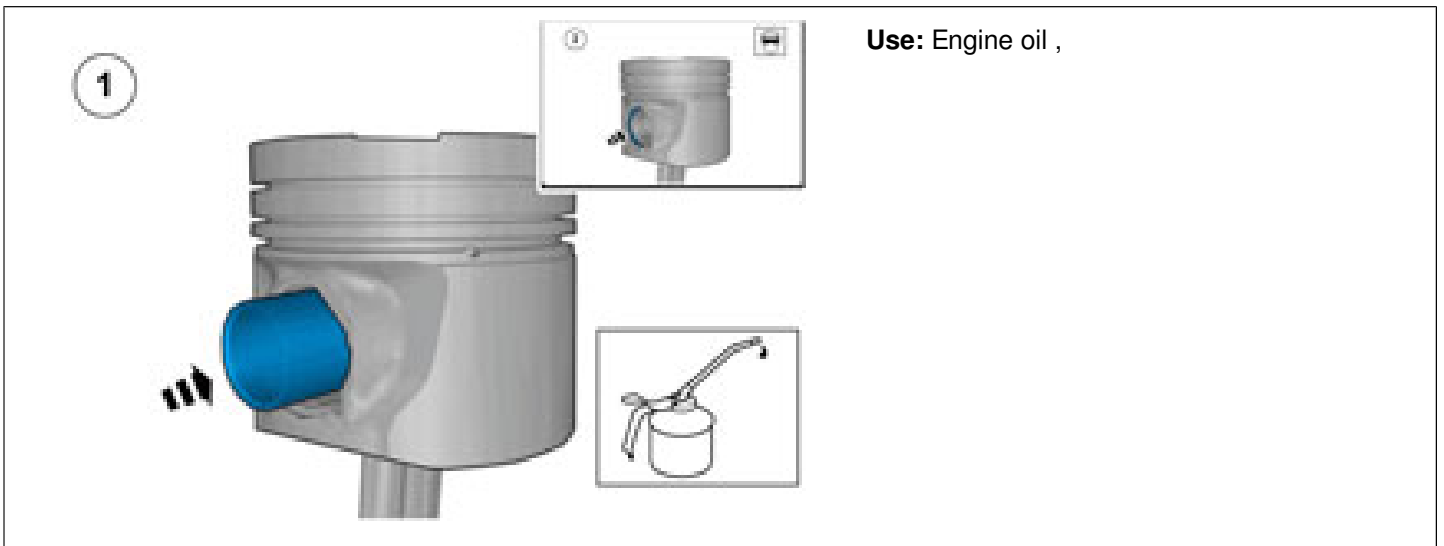

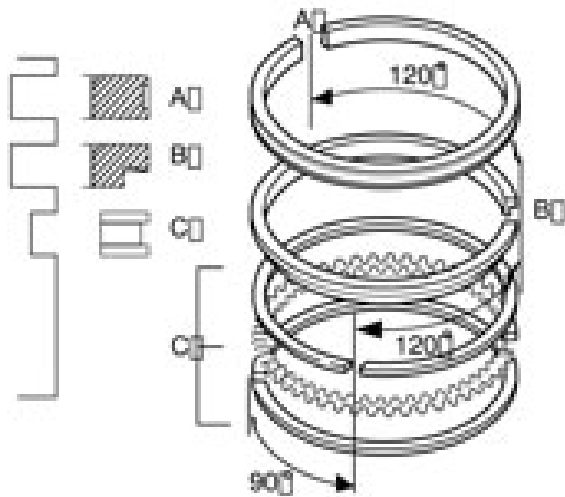

Caution! Make sure that the piston rings can be easily rotated by hand in the piston ring grooves.

Note! Text or marking on piston ring A must be face up.

Note! The piston rings must not be expanded more than necessary.

Use: Piston ring pliers

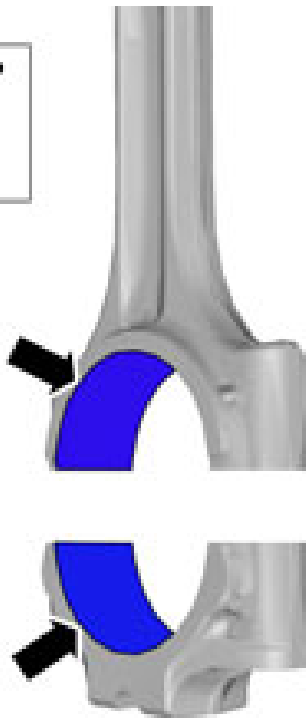

Warning! Make sure that the component is positioned correctly.

Caution! Make sure that the mating faces are clean and free of foreign material.

Use: Engine oil ,

Make sure to replace the marked component with a new.

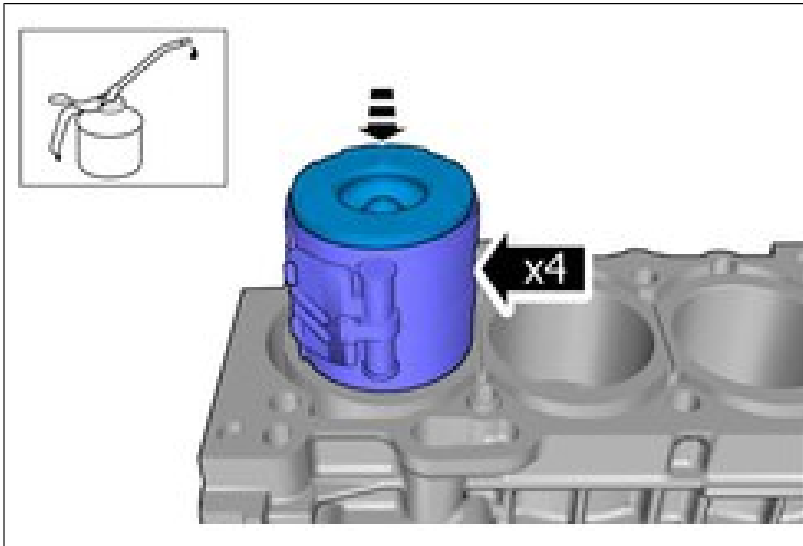
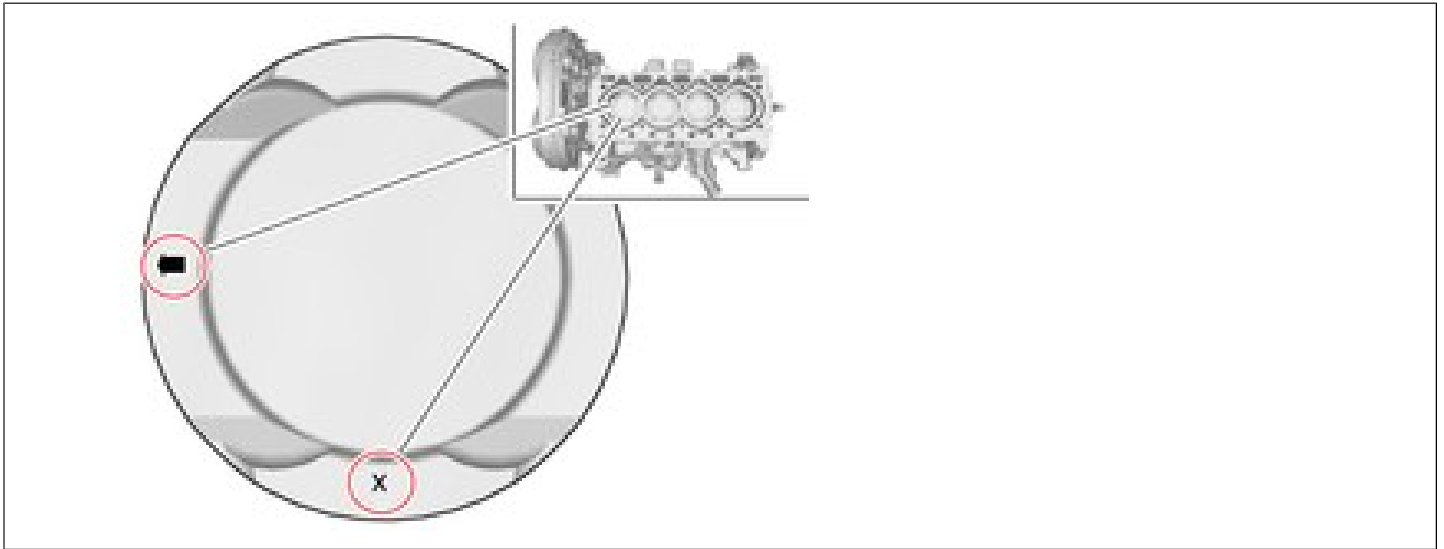

Caution! Take extra care when handling the components.

Use: Engine oil ,

Use: Piston ring compressor

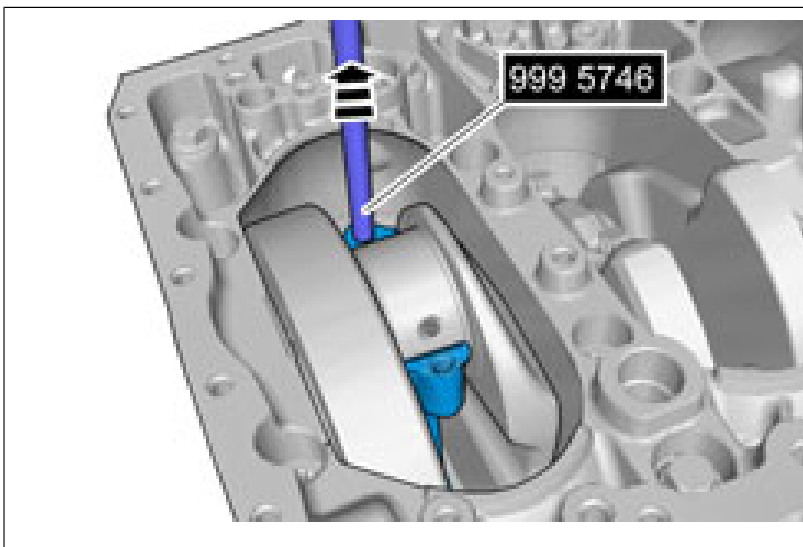

Caution! Take extra care when handling the components.

Special Tool: T9995746, Holder (remov.piston/ connecting rod) B 200-B 6304

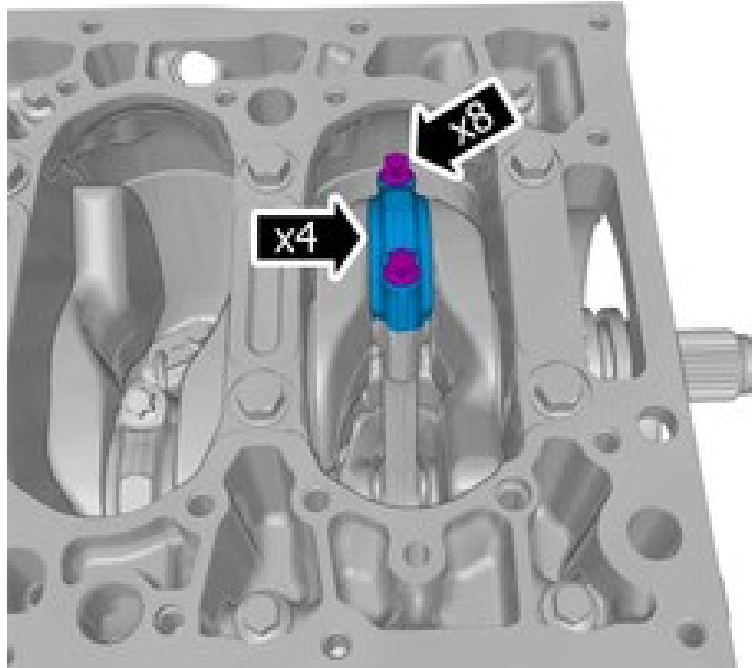

Warning! Make sure that new bolts are installed.

Caution! Take extra care when handling the components.

Install the marked component.
Tighten the bolts.

Torque:

- Stage 1 : Cap connecting rod , 15 Nm
- Stage 2 : Cap connecting rod , 25 Nm
- Stage 3 : Cap connecting rod , 90°

Install balance shaft unit , refer to:
Removal, replacement and installation
2 - Engine with mountings and equipment
21 - Engine
215 - transmission

Install cylinder head , refer to:
Removal, replacement and installation
2 - Engine with mountings and equipment
21 - Engine
211 - cylinder head