

NON COMPLIANCE RECALL

Mack Trucks Inc.
Greensboro, NC USA



Date	Number	Release	Page
11.2019	EC0020C	01	1(16)

Cabover, Analysis & SCR Hardware Replacement - 2 box MR, TE, LR

NON COMPLIANCE RECALL INFORMATION

(November 2019)

Mack Trucks has determined that certain model year 2017-2018 MP7/MP8 model engines may be equipped with an improperly functioning SCR (Selective Catalytic Reduction) system due to Low NOx Conversion Efficiency DTC (Diagnostic Trouble Code), which may cause a loss of catalyst performance that violates Federal and California standards and regulations. The root cause is that water is chemically bonding and deactivating the catalyst during extended low temperature operation followed by high temperature operation.

This issue is to be addressed by updating ECM software, inspecting DEF system, running Premium Tech Tool function "Exhaust Aftertreatment System Analysis", replacing the SCR system with one containing an improved hybrid catalyst, and returning the SCR as instructed.

Follow the procedure outlined in this document.

VEHICLES AFFECTED

Certain Mack North America vehicles manufactured between October 16th, 2017 and September 25th, 2018.

VEHICLE QUANTITY

There are 347 vehicles affected by this recall (320 U.S., 27 Canada).

Material Needed

REQUIRED PARTS:

Order parts through standard Parts Distribution Center (PDC) process.

Parts List			
Item	Part Number	Description	Qty
1	23190007	Muffler Hybrid SCR 2-Box Bottom	1
2	21021850	V-Clamp	1
2	21095726	Gasket	1
4	22998036	Strap	4
5	85152363	Decal (Campaign Completion Decal) NOTE: N/A if previously installed on truck	1
6	N/A	Vehicle Emissions Recall – Proof of Correction Certificate US-CAN (EN) NOTE: See last page of recall for this form	1

REQUIRED TOOLS

- Premium Tech Tool (PTT) version 2.7.75 or higher
- Vocom (one of the following 16 Pin cables) 88890304, 88890253, or 88894001
- Vocom Communication Interface 88890300, or 88894000
- Vocom USB Cable 88890313
- Refractometer 88890105
- Litmus paper 88890110

NOTE
Using other interfaces may affect programming speed.

NOTE
Ensure PTT version 2.7.75 or higher is used for complete PTT functionality. Earlier versions of PTT will not have functions for the following steps to complete this recall. Check Premium Tech Tool version by clicking on Help tab and then click on “About Tech Tool”.

Repair – All Mack MR, TE, LR Chassis configurations.

Repair Index		
Section	Description	Page Number
1	Update Software	4
2	Inspection, DEF	5
3	Exhaust Aftertreatment System Analysis Test	5
4	SCR Replacement	9
5	Inspection, SCR Crystallization	10
6	SCR Return Policy	10
7	Label & Certificate	12
8	Reimbursement	14

UPDATE SOFTWARE

You must read and understand the precautions and guidelines in Service Information, group 30, "General Safety Practices, Electrical" before performing this procedure. If you are not properly trained and certified in this procedure, ask your supervisor for training before you perform it.

NOTE: Information is subject to change without notice. Illustrations are used for reference only and can differ slightly from the actual vehicle being serviced. However, key components addressed in this information are represented as accurately as possible.



Do not attempt to repair or service this vehicle without having sufficient training, the correct service literature and the proper tools. Failure to follow this could make the vehicle unsafe and lead to serious personal injury or death.

1. Park the vehicle on a flat and level surface.
2. Apply the parking brake.
3. Place the transmission in neutral or park.
4. Install the wheel chocks.

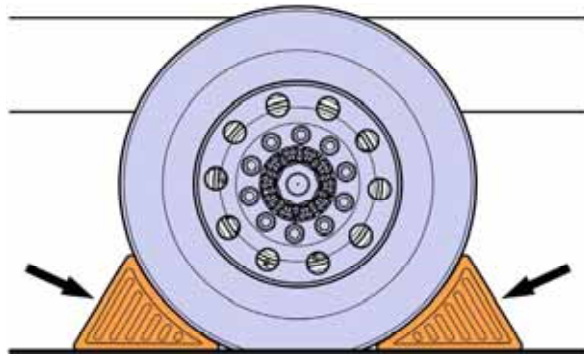

5. Using Premium Tech Tool (PTT), connect to the vehicle
6. Update EMS Software to Part Number **23766686**.
7. **Note:** Follow the on screen prompts until the programming is complete.
8. Disconnect the vehicle from Premium Tech Tool (PTT)

INSPECTION, DEF

NOTE

Record values for steps 9 through 11 and steps 22 through 24 on the “DEF Inspection Check List” found page 15. This sheet will need to be saved and uploaded to UCHP with the claim information.

9. Inspect DEF Quality using a Refractometer (P/N 88890105). Record Value.
10. Inspect DEF Quality using a Litmus Paper (P/N 88890110). Circle “Pass” or “Fail”.
11. Inspect DEF Tank for contamination of any dirt, debris, coolant, water fuel, oil etc. Circle answer “Yes” or “No”.

NOTE

If contaminants are found, continue with recall procedures. Once recall is completed consult with customers for repair of the contaminated DEF system.

EXHAUST AFTERTREATMENT SYSTEM ANALYSIS

NOTE

Regardless of results from Exhaust Aftertreatment System Analysis, if the test aborts before completing, or if the test fails to progress to next step for 15 minutes continue to step 21 of this recall.

NOTE

Before continuing ensure PTT version 2.7.75 or higher is used for complete PTT functionality and the ECM Software is updated to 23766686. In addition, PTT may require to be restarted and a new work session opened for the “Exhaust Aftertreatment System Analysis” to function.

12. Start the PC and open Premium Tech Tool (PTT).
13. Connect the interface to PC and vehicle. Ignition switch needs to be in the “on” position.
14. Perform identification and connection dialog.

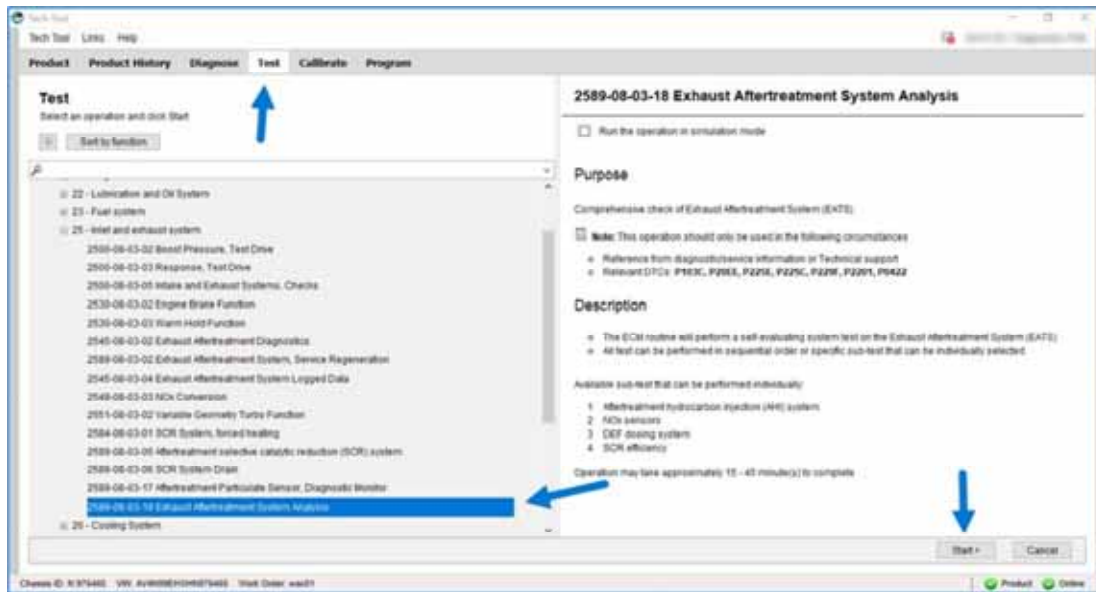

15.

From the “Test” tab, select “2589-08-03-18 Exhaust Aftertreatment System Analysis” and then select “Start”.

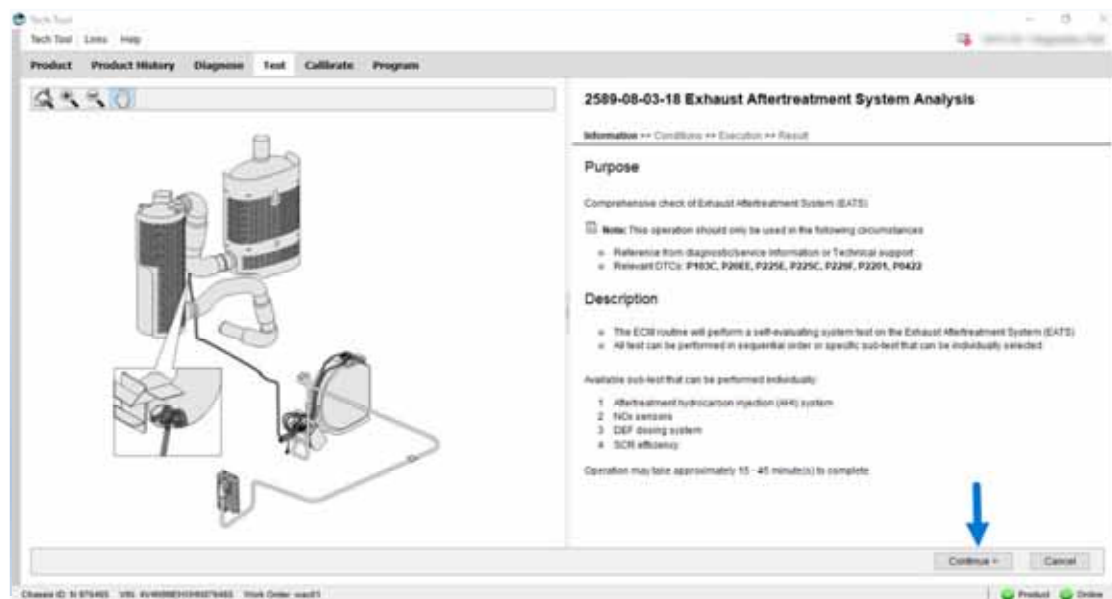

16.

Select “Continue”.

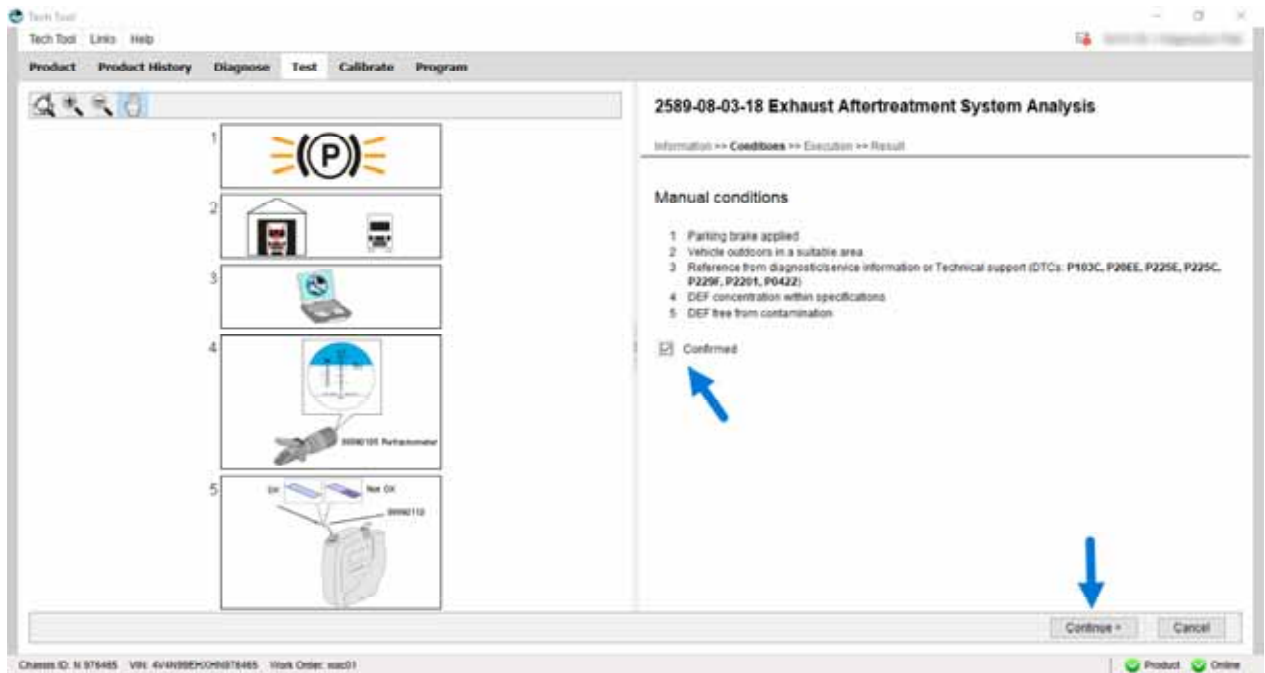

17. Verify the manual conditions are met, check the “Confirmed” box, and the select “Continue”.

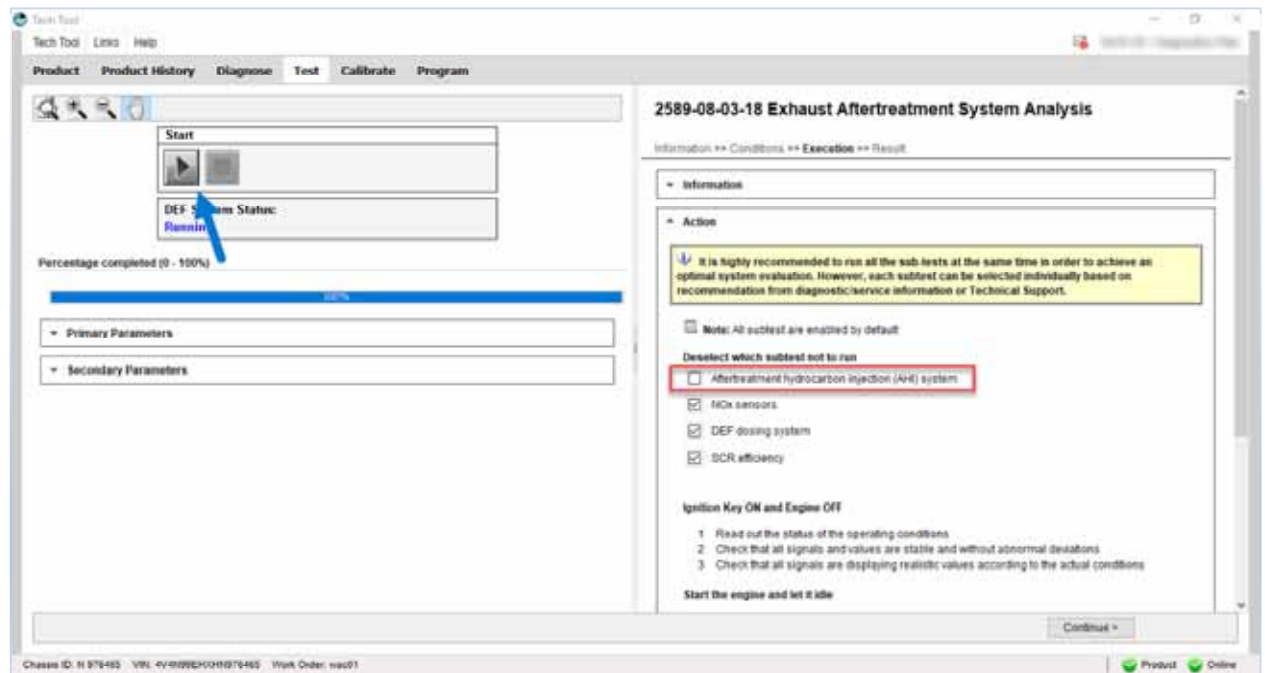

18. Uncheck “Aftertreatment Hydrocarbon Injection (AHI) System Box, and select “Start” on the upper left side of the screen.



Wait for test to go through all phases of the operation. Note the blue indicator on the right will move through each phase.

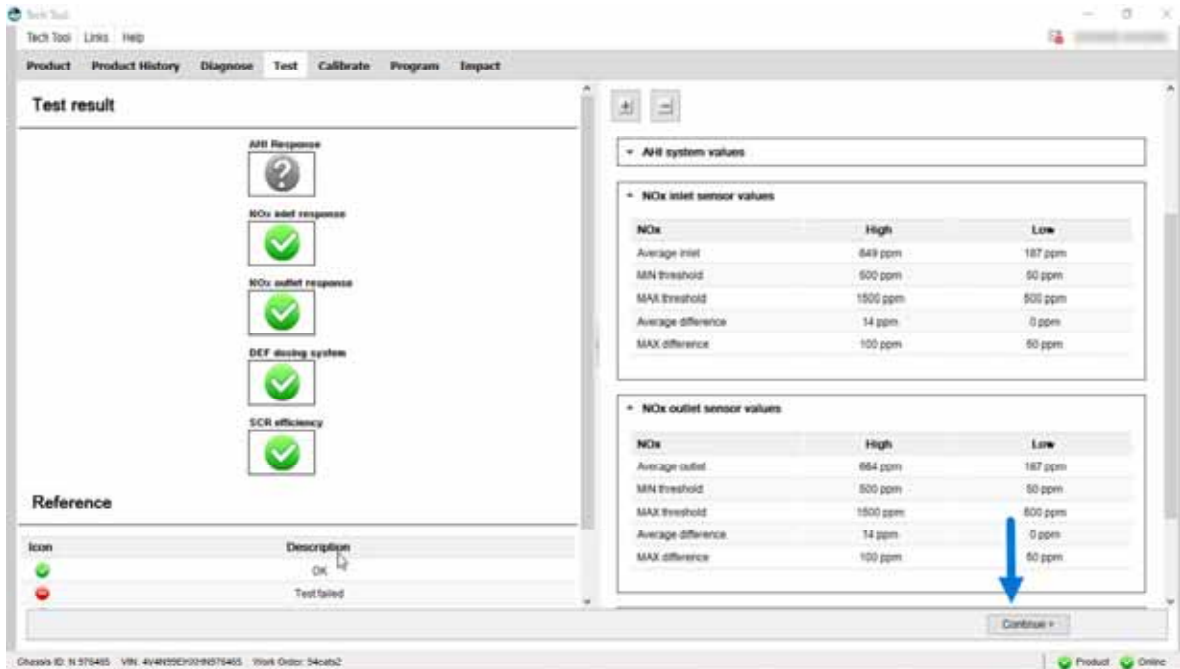

19. Once the test is complete, results will populate. **Regardless of results** select continue. Return to the main screen in PTT and select "Finish Work".

20. You may now disconnect the interface from PC and vehicle. Turn ignition off.
For More Information on the PTT Function Visit: <http://www.premiumtechttool.com>

SCR REPLACEMENT

21. Follow standard repair instructions and parts list per model key listed below (Ref. Image #1).

Operation ID		
Model	Repair Operation	Repair Identity
MR	2586-03-02-01	138458241
TE	2586-03-02-01	144179816
LR	2586-03-02-01	144179844

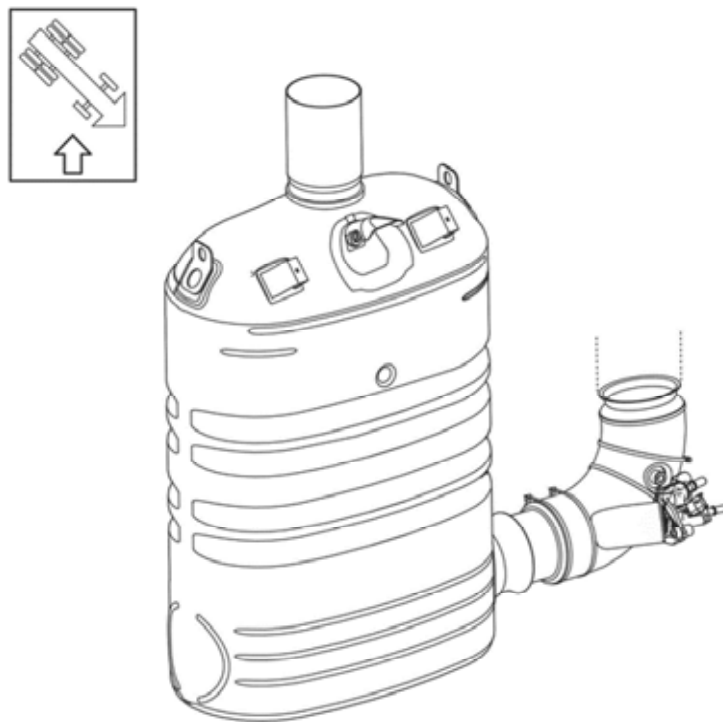

Image #1- 2-Box Selective Catalytic Reduction (SCR)

INSPECTION, SCR CRYSTALLIZATION

NOTE

Record values for steps 9 through 11 and steps 22 through 24 on the “DEF Inspection Check List” found page 15. This sheet will need to be saved and uploaded to UCHP with the claim information.
--

- 22. Inspect DEF Dosing Valve for excessive crystallized DEF – Circle found condition
- 23. Inspect SCR Diffuser Pipe for excessive crystallized DEF – Circle found condition
- 24. Inspect SCR Inlet for excessive crystallized DEF – Circle found condition

SCR RETURN PROCESS

The UCHP Claim (part return) will be arriving in your “MI Tab” within no later than 7 days after crediting. Please follow the below shipping instructions on the UCHP shipping documents

- 25. Ensure all plugs and caps supplied with the new SCR are reused and installed on returned part. Securely band SCR to Pallet.

NOTE

All SCR openings must be sealed to eliminate contamination. If plugs and caps are damaged use water proof tape to cover the openings.



- 26. Record failed SCR Part Number, Serial number to enter into UCHP Claim

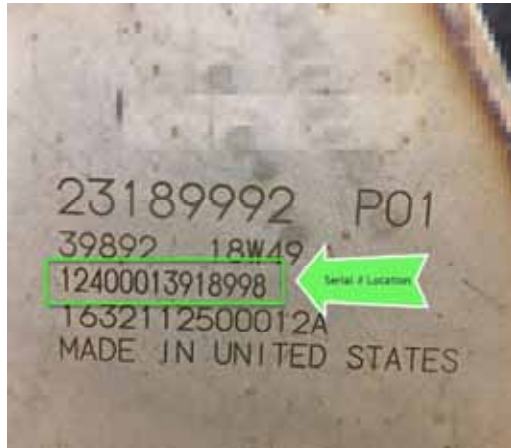

27. Enter Failed SCR Serial Number in UCHP Claim for the Failed/Casual Part & New Part.

Claim job information		Labour	Material	Other costs	Remarks	History	
Causal part							
Prefix	Part number	Description				Func. group	Serial number
VO	12345678	MUFFLER				2586	111111111111
<input checked="" type="radio"/> Replaced <input type="radio"/> Repaired							
Included material							
New Prefix	Part number	Description				Serial number	
<input type="radio"/> VO	87654321					999999999999	
<input type="button" value="Add row"/> <input type="button" value="Copy row"/>							

28. Attach TMAC return label per normal process to return shipment.

REIMBURSEMENT

This repair is covered by an authorized Non Compliance Recall Campaign. Reimbursement is obtained through the normal claim handling process.	
	UHP Reimbursement
Claim Type (used only when uploading from the Dealer Business System)	40
Recall Status	
Vehicle repaired per instructions	1-Modified per instructions
Labor Codes	
Primary Labor Code: Aftertreatment Selective catalytic Reduction (SCR) Catalyst, Replacement	2586-03-02-01 Models MR, TE, LR 2.3 hrs
Exhaust Aftertreatment System Analysis	2589-08-03-18 1.0
Program Engine Electronic Control Unit	2840-22-03-01 0.5
Causal Part	22058306
Authorization Number	M0068

Note: Dealers are to perform Non Compliance Recall on all subject vehicles at no charge to the vehicle owner regardless of mileage, age of vehicle or ownership (original purchaser or subsequent purchasers). Whenever vehicles are subject to a Non Compliance Recall are brought to your dealership for service, or taken into your dealership vehicle inventory, it is strongly recommended that every effort be made to perform the recall correction before the vehicle is sold or released to the owner.

<u>Step</u>	<u>Inspection Check List</u>	<u>Data Input</u>
1	Inspect DEF Quality using Refractometer (P/N - 88890105) and Record Value	VALUE _____
2	Inspect DEF Quality using litmus paper (P/N - 88890110) and Circle Pass or Fail	PASS / FAIL
3	Inspect DEF Tank for contamination of any dirt, debris, coolant, water, fuel, oil, etc. - Contamination found, circle answer	YES / NO
4	With SCR Removed - Inspect DEF dosing valve for excessive crystallized DEF - Circle found Condition	NONE / MINIMAL / MODERATE / SEVERE
5	With SCR Removed - Inspect SCR Diffuser Pipe for excessive crystallized DEF - Circle found condition	NONE / MINIMAL / MODERATE / SEVERE
6	With SCR Removed - Inspect SCR Inlet for excessive crystallized DEF - Circle found condition	NONE / MINIMAL / MODERATE / SEVERE

