



Emissions Service Action

Code: 26M9

REVISION

Subject Reducing Agent Injector and SCR Catalyst (Parts Catalog Error)

Release Date November 21, 2019

Revision Summary Part number for dual clamp corrected in the required parts section and work procedure.

Affected Vehicles

Country	Beginning Model Year	Ending Model Year	Vehicle	Vehicle Count
USA	2010	2013	Q7	12
CAN	2011	2012	Q7	2

Check Campaigns/Actions screen in Elsa on the day of repair to verify that a VIN qualifies for repair under this action. Elsa is the only valid campaign inquiry & verification source.

- ✓ Campaign status must show "open."
- ✓ If Elsa shows other open action(s), inform your customer so that the work can also be completed at the same time the vehicle is in the workshop for this campaign.

Problem Description Due to a parts catalog error, incorrect emissions related component(s) may have been installed on some vehicles during a past service repair visit. Dealers will inspect and, if needed, replace the component(s) as a proactive measure to ensure continued emissions compliance.

Corrective Action Inspect and, if needed, replace the component(s) as a proactive measure to ensure continued emissions compliance.

IMPORTANT! AEM Not Required To Receive This Repair This action is fully independent of the approved diesel modification recall on affected vehicles. For customer convenience, this action can be performed at the same time as other service work, but can also be done independent of the diesel modification (AEM). Customers do not need to receive the diesel modification (AEM) in order to receive this repair.

Parts Information

Parts Control Type: VIN to order	Due to the small number of affected vehicles there will not be a parts allocation. Please reference the Repair Projection Tool (below) to view your potential VIN population. If parts are needed to support a vehicle repair: <ul style="list-style-type: none"> • US Dealers - use AVA • CAN Dealers - contact the Parts Specialists via phone (800-767-6552), email (VWoAPartsSpecialists@vw.com), or chat/text with the VIN to order
---	--

Criteria	Part Number	Description (per POC)	Qty. per Vehicle	Ordering Method
02	4L0-254-400-AX	Catalyst	1	VIN to Order
02	7L8-254-400-RX	Catalyst	1	VIN to Order
ALL	ALL OTHERS			Free Order

Repair Projection Tool (right click to open): 

Dealers are urged to order parts only to support scheduled customer repairs.

The repair information in this document is intended for use only by skilled technicians who have the proper tools, equipment and training to correctly and safely maintain your vehicle. These procedures are not intended to be attempted by "do-it-yourselfers," and you should not assume this document applies to your vehicle, or that your vehicle has the condition described. To determine whether this information applies, contact an authorized Audi dealer. ©2019 Audi of America, Inc. and Audi Canada. All Rights Reserved.

Code Visibility	Dealers must ensure these customer repairs are scheduled so that the correct parts are on hand at the dealership when the customer presents their vehicle for this service.
Owner Notification	On or about November 20, 2019, the campaign code was applied to the affected vehicles. Owner notification will take place in November 2019. Owner letter examples are included in this bulletin for your reference.
Emissions Campaigns Requirements (CALIFORNIA ONLY)	The California Air Resources Board and the Department of Motor Vehicles (DMV) require emissions-related campaigns to be completed prior to vehicle registration renewal. When campaign work is done you must provide the owner with a signed "Vehicle Emission Recall – Proof of Correction" certificate (RC EMISCAVWAWU). Order certificates online via the Compliance Label Ordering portal at www.accessaudi.com .
Additional Information	<p>Please alert everyone in your dealership about this action, including Sales, Service, Parts and Accounting personnel. Contact Warranty if you have any questions.</p> <p>Dealers must ensure that every affected inventory vehicle has this campaign completed <u>before delivery to consumers</u>.</p> <p>Fill out and affix Campaign Completion Label (CAMP 010 000) after work is complete. <i>Labels can be ordered at no cost via the Compliance Label Ordering portal at www.accessaudi.com.</i></p>

Claim Entry Instructions

After campaign has been completed, enter claim as soon as possible to help prevent work from being duplicated elsewhere. Attach the Elsa screen print showing action open on the day of repair to the repair order.

If customer refused campaign work:

- ✓ U.S. dealers: Submit the request through Audi Warranty Online under the Campaigns/Update option.
- ✓ Canada dealers: Upload the repair order [signed by customer] to Audi WIN/Operations/Campaign Closure.

Service Number	26M9																		
Damage Code	0099																		
Parts Vendor Code	002																		
Claim Type	Sold vehicle: 7 10 Unsold vehicle: 7 90																		
Causal Indicator	Select labor* as causal for inspection only OR Select Injector for Reduction Agent* as causal part OR Select Catalyst* as causal part																		
Vehicle Wash/Loaner	Do not claim wash/loaner under this action																		
Criteria I.D.	01																		
	<p>Inspect Reducing Agent Injector, correct part present, no further work required</p> <p>Labor operation: 2685 01 99* 30 T.U.</p> <table border="1"> <thead> <tr> <th>Quantity</th> <th>Part Number</th> <th>Description</th> </tr> </thead> <tbody> <tr> <td>1.00</td> <td>3C0253725</td> <td>Retaining clip</td> </tr> <tr> <td>1.00</td> <td>3C0253115A</td> <td>Gasket</td> </tr> </tbody> </table> <p>-OR-</p> <p>Inspect Reducing Agent Injector, incorrect part present, replace Reducing Agent Injector</p> <p>Labor operation: 2685 19 99 40 T.U.</p> <table border="1"> <thead> <tr> <th>Quantity</th> <th>Part Number</th> <th>Description</th> </tr> </thead> <tbody> <tr> <td>1.00</td> <td>4H0131113A</td> <td>Injector for reduction agent*</td> </tr> <tr> <td>1.00</td> <td>3C0253725</td> <td>Retaining clip</td> </tr> </tbody> </table>	Quantity	Part Number	Description	1.00	3C0253725	Retaining clip	1.00	3C0253115A	Gasket	Quantity	Part Number	Description	1.00	4H0131113A	Injector for reduction agent*	1.00	3C0253725	Retaining clip
Quantity	Part Number	Description																	
1.00	3C0253725	Retaining clip																	
1.00	3C0253115A	Gasket																	
Quantity	Part Number	Description																	
1.00	4H0131113A	Injector for reduction agent*																	
1.00	3C0253725	Retaining clip																	

Criteria I.D.	02																																				
	<p>Inspect SCR Catalyst, correct part present, no further work required Labor operation: 0183 00 99* 30 T.U.</p> <p>-OR-</p> <p>Inspect SCR Catalyst, incorrect part present, replace SCR Catalyst Labor operation: 2673 19 99 90 T.U.</p> <table border="1"> <thead> <tr> <th>Quantity</th> <th>Part Number</th> <th>Description</th> </tr> </thead> <tbody> <tr> <td>1.00</td> <td>4L0254400AX</td> <td>Catalyst* (2012 MY ONLY)</td> </tr> <tr> <td colspan="3" style="text-align: center;">-OR-</td> </tr> <tr> <td>1.00</td> <td>7L8254400RX</td> <td>Exhaust Pipe With Catalyst And Adapters* (2010 MY ONLY)</td> </tr> <tr> <td colspan="3" style="text-align: center;">-AND (all model years)-</td> </tr> <tr> <td>1.00</td> <td>1K0253141J</td> <td>Dual clamp</td> </tr> <tr> <td>1.00</td> <td>3C0253115A</td> <td>Gasket</td> </tr> <tr> <td>1.00</td> <td>3C0253725</td> <td>Retaining clip</td> </tr> <tr> <td>1.00</td> <td>7L5253115C</td> <td>Gasket</td> </tr> <tr> <td>3.00</td> <td>N 91130802</td> <td>Shouldered Hex Nut Self-Locking</td> </tr> <tr> <td>Up to 3.00</td> <td>N 01024713</td> <td>Screw (if necessary)</td> </tr> <tr> <td>1.00</td> <td>WHT003487A</td> <td>Plug</td> </tr> </tbody> </table>	Quantity	Part Number	Description	1.00	4L0254400AX	Catalyst* (2012 MY ONLY)	-OR-			1.00	7L8254400RX	Exhaust Pipe With Catalyst And Adapters* (2010 MY ONLY)	-AND (all model years)-			1.00	1K0253141J	Dual clamp	1.00	3C0253115A	Gasket	1.00	3C0253725	Retaining clip	1.00	7L5253115C	Gasket	3.00	N 91130802	Shouldered Hex Nut Self-Locking	Up to 3.00	N 01024713	Screw (if necessary)	1.00	WHT003487A	Plug
Quantity	Part Number	Description																																			
1.00	4L0254400AX	Catalyst* (2012 MY ONLY)																																			
-OR-																																					
1.00	7L8254400RX	Exhaust Pipe With Catalyst And Adapters* (2010 MY ONLY)																																			
-AND (all model years)-																																					
1.00	1K0253141J	Dual clamp																																			
1.00	3C0253115A	Gasket																																			
1.00	3C0253725	Retaining clip																																			
1.00	7L5253115C	Gasket																																			
3.00	N 91130802	Shouldered Hex Nut Self-Locking																																			
Up to 3.00	N 01024713	Screw (if necessary)																																			
1.00	WHT003487A	Plug																																			
Criteria I.D.	01 AND 02																																				
	<p>Inspect SCR Catalyst and Reducing Agent Injector, correct parts present, reinstall injector, no further work required Labor operation: 2685 01 99* 40 T.U.</p> <table border="1"> <thead> <tr> <th>Quantity</th> <th>Part Number</th> <th>Description</th> </tr> </thead> <tbody> <tr> <td>1.00</td> <td>3C0253725</td> <td>Retaining clip</td> </tr> <tr> <td>1.00</td> <td>3C0253115A</td> <td>Gasket</td> </tr> </tbody> </table> <p>-OR-</p> <p>Inspect SCR Catalyst and Reducing Agent Injector, incorrect parts present, replace SCR Catalyst and Reducing Agent Injector Labor operation: 2673 20 99 90 T.U.</p> <table border="1"> <thead> <tr> <th>Quantity</th> <th>Part Number</th> <th>Description</th> </tr> </thead> <tbody> <tr> <td>1.00</td> <td>4L0254400AX</td> <td>Exhaust Pipe With Catalyst And Adapters*</td> </tr> <tr> <td>1.00</td> <td>1K0253141J</td> <td>Dual clamp</td> </tr> <tr> <td>1.00</td> <td>3C0253725</td> <td>Retaining clip</td> </tr> <tr> <td>1.00</td> <td>4H0131113A</td> <td>Injector for reduction agent</td> </tr> <tr> <td>1.00</td> <td>7L5253115C</td> <td>Gasket</td> </tr> <tr> <td>3.00</td> <td>N 91130802</td> <td>Shouldered Hex Nut Self-Locking</td> </tr> <tr> <td>Up to 3.00</td> <td>N 01024713</td> <td>Screw (if necessary)</td> </tr> <tr> <td>1.00</td> <td>WHT003487A</td> <td>Plug</td> </tr> </tbody> </table>	Quantity	Part Number	Description	1.00	3C0253725	Retaining clip	1.00	3C0253115A	Gasket	Quantity	Part Number	Description	1.00	4L0254400AX	Exhaust Pipe With Catalyst And Adapters*	1.00	1K0253141J	Dual clamp	1.00	3C0253725	Retaining clip	1.00	4H0131113A	Injector for reduction agent	1.00	7L5253115C	Gasket	3.00	N 91130802	Shouldered Hex Nut Self-Locking	Up to 3.00	N 01024713	Screw (if necessary)	1.00	WHT003487A	Plug
Quantity	Part Number	Description																																			
1.00	3C0253725	Retaining clip																																			
1.00	3C0253115A	Gasket																																			
Quantity	Part Number	Description																																			
1.00	4L0254400AX	Exhaust Pipe With Catalyst And Adapters*																																			
1.00	1K0253141J	Dual clamp																																			
1.00	3C0253725	Retaining clip																																			
1.00	4H0131113A	Injector for reduction agent																																			
1.00	7L5253115C	Gasket																																			
3.00	N 91130802	Shouldered Hex Nut Self-Locking																																			
Up to 3.00	N 01024713	Screw (if necessary)																																			
1.00	WHT003487A	Plug																																			

Customer Letter Example (United States)

<MONTH YEAR>

<CUSTOMER NAME>

<CUSTOMER ADDRESS>

<CUSTOMER CITY STATE ZIPCODE>

This notice applies to your vehicle: <VIN>

Subject: Emissions Service Action 26M9 - Reducing Agent Injector and/or SCR Catalyst

Dear Audi Owner,

In cooperation with the United States Environmental Protection Agency and the California Air Resources Board, we are informing you of our decision to conduct an emissions service action on certain 2010-2013 model year Audi Q7 TDI vehicles. Our records show that you are the owner of a vehicle affected by this action.

Please note: This action is fully independent of the approved diesel modification recall on your vehicle. For your convenience, this action can be performed at the same time as other service work, but can also be done independent of the diesel modification. You do not need to receive the diesel modification in order to receive this repair.

- What is the issue?** Due to a parts catalog error, incorrect emissions related component(s) may have been installed on some vehicles during a past service repair visit. Dealers will inspect and, if needed, replace the component(s) as a proactive measure to ensure continued emissions compliance.
- What will we do?** Your authorized Audi dealer will inspect and, if necessary, install the correct components. This work will take about two hours to complete and will be performed for you free of charge. Please keep in mind that your dealer may need additional time for the preparation of the repair, as well as to accommodate their daily workshop schedule.
- What should you do?** In order to limit any possible inconvenience, please contact your authorized Audi dealer as soon as possible to schedule this service. For your convenience, you can also visit www.audiusa.com and click on the "Find a Dealer" link to locate a dealer near you and schedule this service.
- Lease vehicles and address changes** If you are the lessor and registered owner of the vehicle identified in this action, please forward this letter immediately via first-class mail to the lessee within ten (10) days of receipt. If you have changed your address or sold the vehicle, please fill out the enclosed prepaid Owner Reply card and mail it to us so we can update our records.
- Important information for California Vehicle Owners – California Regulations** California regulations require that this campaign be completed prior to the time you renew your vehicle registration. Therefore, **please make sure that this campaign is completed prior to the renewal of your vehicle registration**, and that you furnish proof of completion to the Department of Motor Vehicles (DMV) in the form of a copy of the dealer's repair order, including a signed "Proof of Correction" certificate. You obtain this from your dealer after the campaign has been completed. Please retain the signed "Proof of Correction Certificate" with your vehicle records. DO NOT MAIL THIS FORM to the DMV, unless requested.
- Can we assist you further?** If your authorized Audi dealer fails or is unable to complete this work free of charge within a reasonable time, please contact Audi Customer Experience at 1-800-253-2834 or via our "Contact Us" page at www.audiusa.com.
- Checking your vehicle for open Recalls and Service Campaigns** To check your vehicle's eligibility for repair under this or any other recall/service campaign, please visit the **Recall/Service Campaign Lookup** tool at www.audiusa.com and enter your Vehicle Identification Number (VIN).

We apologize for any inconvenience this matter may cause; however we are taking this action to help ensure your vehicle continues to meet and exceed your expectations.

Sincerely,

Audi Customer Protection

Customer Letter Example (CANADA)

<MONTH YEAR>

<CUSTOMER NAME>

<CUSTOMER ADDRESS>

<CUSTOMER CITY STATE ZIPCODE>

This notice applies to your vehicle: <MODEL YEAR> <BRAND> <CARLINE>, <VIN>

Subject: Emissions Service Action 26M9 - Reducing Agent Injector

Dear Audi Owner,

This notice is sent to you in accordance with the requirements of the *Canadian Environmental Protection Act, 1999*. Audi has determined that a defect, which relates to a prescribed emission standard, exists in certain 2011-2012 model year Audi Q7 TDI vehicles. Our records show that you are the owner of a vehicle affected by this action.

- What is the issue?** Due to a parts catalog error, incorrect emissions related component(s) may have been installed on some vehicles during a past service repair visit. Dealers will inspect and, if needed, replace the component(s) as a proactive measure to ensure continued emissions compliance.
- What will we do?** Your authorized Audi dealer will inspect and, if necessary, install the correct component(s). This work will take about two hours to complete and will be performed for you free of charge. Please keep in mind that your dealer may need additional time for the preparation of the repair, as well as to accommodate their daily workshop schedule.
- What should you do?** In order to limit any possible inconvenience, please contact your authorized Audi dealer as soon as possible to schedule this service. On or about November 19, 2019, the necessary repair instructions and parts will be available to your authorized Audi dealer.
- Lease vehicles and address changes** If you are the lessor and registered owner of the vehicle identified in this action, please forward this letter immediately via first-class mail to the lessee within ten (10) days of receipt. If you have changed your address or sold the vehicle, please fill out the enclosed prepaid Owner Reply card and mail it to us so we can update our records.
- Can we assist you further?** If your authorized Audi dealer fails or is unable to complete this work free of charge within a reasonable time, please contact Audi Customer Relations Monday through Friday from 8AM to 8PM EST at 1-800-822-2834 or via our "Contact Audi Canada" page at www.audi.ca.

We apologize for any inconvenience this matter may cause; however we are taking this action to help ensure your vehicle continues to meet and exceed your expectations.

Sincerely,

Audi Customer Protection

NOTE

- These repair instructions may differ from the labor operations and labor times listed in ELSA.
- Damages resulting from improper repair or failure to follow these work instructions are the dealer's responsibility and are not eligible for reimbursement under this action.
- This procedure must be read in its entirety prior to performing the repair.
- Due to variations in vehicle equipment and options, the steps/illustrations in this work procedure may not identically match all affected vehicles.
- Diagnosis and repair of pre-existing conditions in the vehicle are not covered under this action.
- When working during extreme temperatures, it is recommended that the vehicle be allowed to acclimate inside the shop to avoid temperature-related component damage/breakage.

Repair Overview

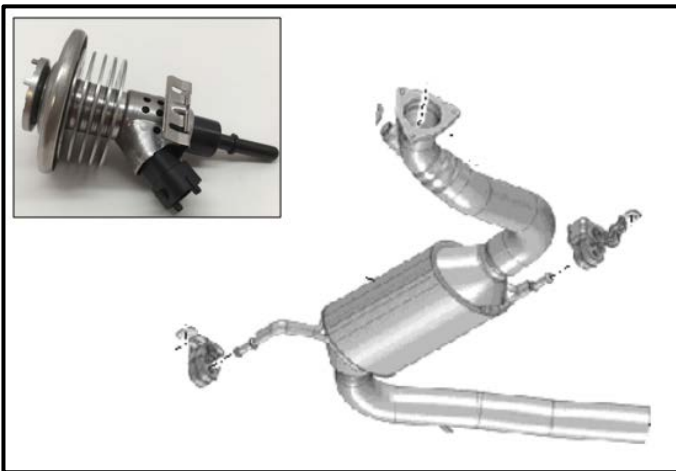

- Inspect and if necessary replace:
 - Reducing Agent Injector
 - and/or-
 - SCR Catalyst

- Section A - Check for Previous Repair
- Section B - Reducing Agent Injector Work Procedure (Criteria 01)
- Section C - SCR Catalyst Work Procedure (Criteria 02)
- Section D - Campaign Completion Stamp
- Section E - Campaign Completion Label
- Section F - Parts Return
- Section G - California Only Requirements



Required Parts

<u>Criteria</u>	<u>Quantity</u>	<u>Part Number</u>	<u>Part Description</u>
01	1	4H0.131.113.A	Reducing Agent Injector
	1	3C0.253.725	Retaining Clamp
-AND/OR-			
02	1	7L8.254.400.RX	SCR Catalyst (2010 MY)
		4L0.254.400.AX	SCR Catalyst (2012 MY)
	1	7L5.253.115.C	Gasket
	1	3C0.253.115.A	Reducing Agent Injector Gasket
	1	3C0.253.725	Retaining Clamp
	1	1K0.253.141.J	Dual Clamp
	3	N 01024713	Replacement Stud/Bolt
	3	N 91130802	Shouldered Hex Nut
	1	WHT.003.487.A	Threaded plug

NOTE

The specified part numbers reflect the status at the start of this service action. Interim updates made in ETKA can cause a listed part number to become unavailable. In this case, the new part number specified in ETKA should be used.

Required Tools

	<p>Socket - 27mm -T40218- (or equivalent)</p>		<p>Special Tool # 582277 (or equivalent)</p>
---	---	--	--

Repair Instruction

Section A - Check for Previous Repair

Applicable criteria ID(s)	Campaign/Action Status
01 ← 2	Open ← 1

EXAMPLE

- Enter the VIN in Elsa and proceed to the “Campaign/Action” screen.

TIP

On the date of repair, print this screen and keep a copy with the repair order.

- Confirm the Campaign/Action is open <arrow 1>. If the status is closed, no further work is required.
- Note the Applicable Criteria ID <arrow 2> for use in determining the correct work to be done and corresponding parts associated.
- **All Safety Recalls MUST be completed before starting this Campaign.**

Proceed to Section B

Section B – Reducing Agent Injector Work Procedure (Criteria 01)



- Remove clamp <A>.
- Leave injector electrical connector plugged in and remove injector from the SCR catalyst.
- Inspect the injector part number:
 - If part number **4H0.131.113.A** is present, no further work is required.
 - **Vehicles with only Criteria 01 open, reinstall the injector with a new gasket and clamp, Proceed to Section E.**
 - **Vehicles with Criteria 02 open, Proceed to Section D.**
 - If any other part number is present or if the part number is unknown:
 - **Proceed to the next step and replace the injector.**

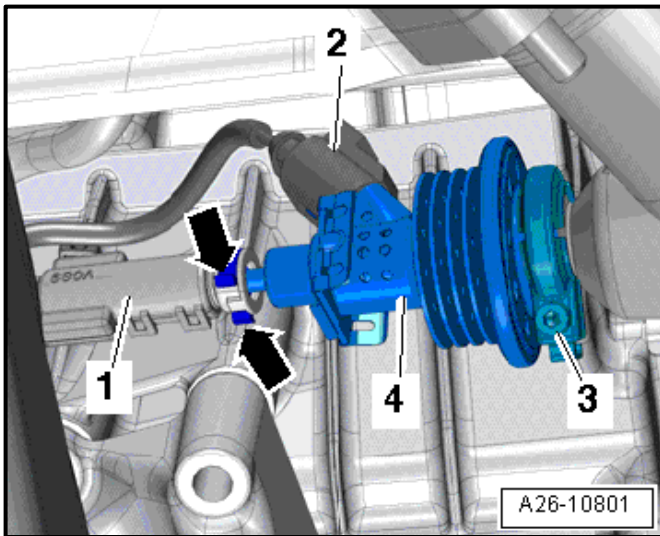

Replace Reducing Agent Injector:

NOTE

- Lay a cloth below to catch any escaping AdBlue reducing agent.
 - Make certain the electrical connector is installed into the new Reducing Agent Injector -N474- before disconnecting the AdBlue reducing agent feed hose. This will reduce the possibility of contaminating the electrical connection with AdBlue.
- Disconnect the connector <2> from the existing Reducing Agent Injector -N474- <4>.
 - Connect the connector <2> to the new Reducing Agent Injector -N474- <4> and set it aside.
 - Make certain the electrical connector is installed into the new Reducing Agent Injector before disconnecting the AdBlue reducing agent feed hose. This will reduce the possibility of contaminating the electrical connection with AdBlue.
 - Remove the AdBlue reducing agent hose <1> by pressing the release clasps <arrows> and remove the reducing agent hose <1>.
 - Connect the AdBlue reducing agent hose <1> to the new Reducing Agent Injector -N474- <4>.



Install Reducing Agent Injector:

- Install Reducing Agent Injector -N474- into the SCR Catalyst pipe ensuring that the tabs in the Injector <arrows> fit into the corresponding mounts in the SCR catalytic converter.

TIP

A new gasket comes pre-installed on a new injector.

- Install a new retaining clamp <A> and tighten the bolt to 5 Nm.

Part Number	Description
3C0.253.725	Retaining Clamp



If Criteria 02 is open on the vehicle:

Proceed to Section C

If Criteria 02 is NOT open on the Vehicle:

All Work Complete, Proceed to Section D

Section C – SCR Catalyst Work Procedure (Criteria 02)

- Inspect the SCR catalyst part number:
 - 2012 MY: If part number **4L0.254.400.AX** is present, no further work is required.
 - 2010 MY: If part number **7L8.254.400.RX** is present, no further work is required.
 - **Proceed to Section E.**
 - If any other part number is present or if the part number is unknown:
 - **Proceed to the next step and replace the SCR catalyst.**

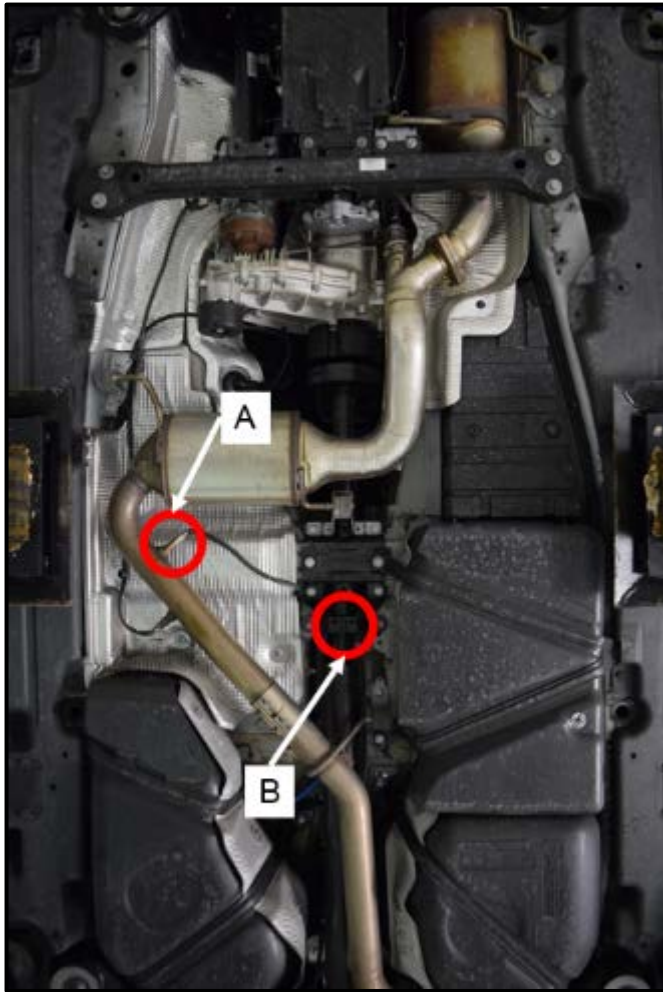
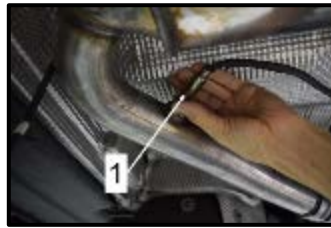

Figure <A>



Remove the NOx #2 sensor <1> from the catalyst pipe.

Figure



Cover the NOx #2 Sensor with a plastic bag (or equivalent) and secure it out of the way with a tie strap (or equivalent) attached through either one of two holes in the rear driveshaft mid-bearing bracket .

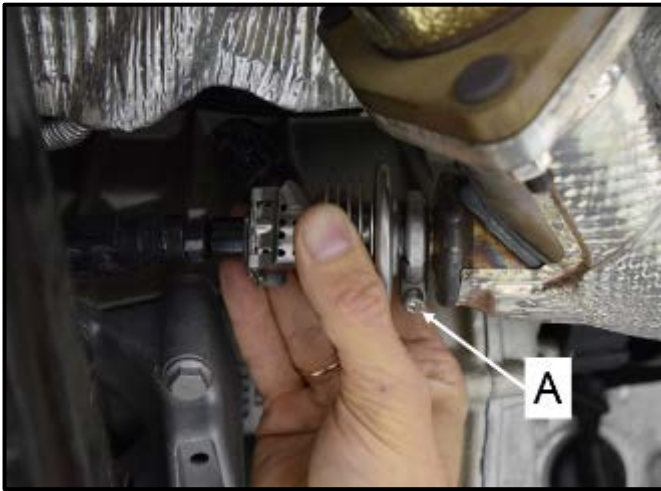

- Loosen the screw <A> and remove the clamp from the Reducing Agent Injector -N474-.
- Leave the electrical connector and the Reducing Agent Injector AdBlue feed line connected at this time. This will reduce the possibility of contaminating the electrical connection with AdBlue.
- Secure the Reducing Agent Injector out of the way with a tie strap (or equivalent).

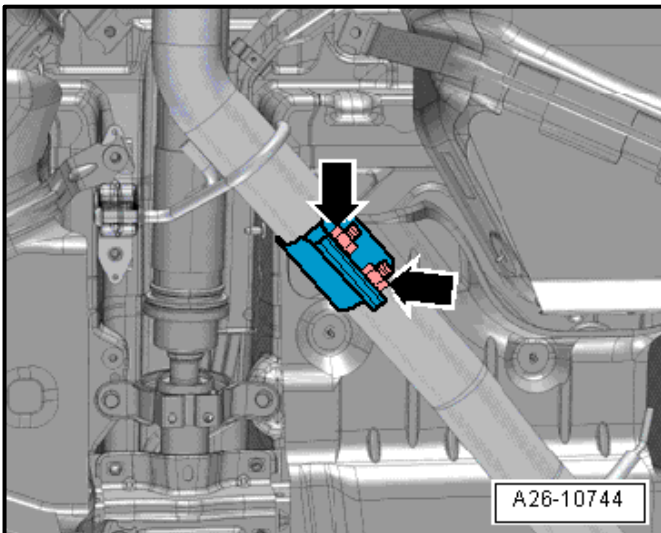

- Loosen the two nuts on the Dual Clamp <arrows> so the clamp can slide back and forth on the exhaust pipe.
- Leave the clamp in the installed position at this time. This will assist in holding the SCR Catalyst in place while removing the brackets in the next step.

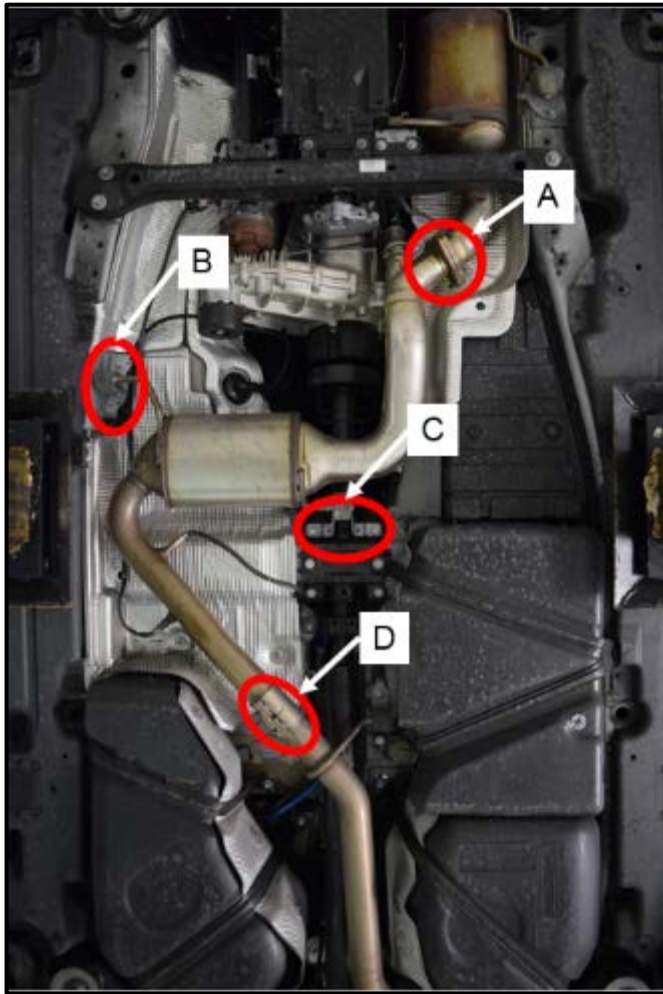

- With the assistance of a second technician, remove the three nuts <A> from the exhaust studs securing the SCR Catalyst to the Diesel Particulate Filter (DPF).
- Remove the bolts from SCR Catalyst brackets at locations <B and C> with assistance from second technician to support the SCR Catalyst while the brackets are removed.
- Slide the Dual Clamp <D> towards the rear of the vehicle, and with the assistance of a second technician, remove the SCR Catalyst from the vehicle.
- Remove the Dual Clamp <D> from the exhaust pipe and discard.

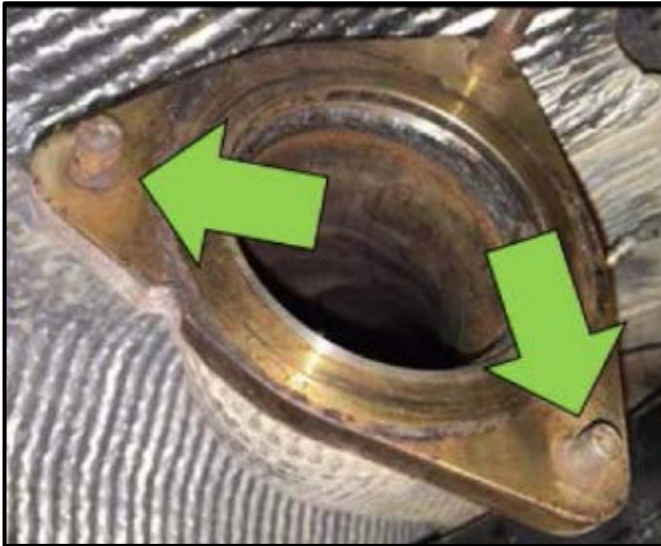

NOTE



Due to corrosion, one or more of the mounting studs may break <arrows> when removing the SCR catalytic converter from the Diesel Particulate Filter (DPF) flange.

DO NOT use a hammer and punch, heat, air hammer, or other method to remove the studs from the DPF. Consequential damage to Exhaust Gas Temperature Sensors, Diesel Particulate Filter, AdBlue Injector Feed Line, or any other ancillary components **WILL NOT BE COVERED** under this action due to damage from heat, impact, or vibration.

Follow the steps below if one or more studs are broken or damaged.

- If stud replacement is necessary use Special Tool # 582277, or a commercially available clevis pin press such as an OTC 5057 or equivalent to press any broken or damaged studs out of the DPF flange.
- It is advised if one stud breaks that all three studs are pressed out and replaced with the bolts/nuts included in the parts kit.
- Install the replacement bolts and corresponding nuts into the rear DPF flange.



Special Tool # 582277



OTC 5057

Part Number	Description	Quantity
N 010.247.13	Replacement Exhaust Bolt	3
N 911.308.02	Shouldered Hex Nut	3

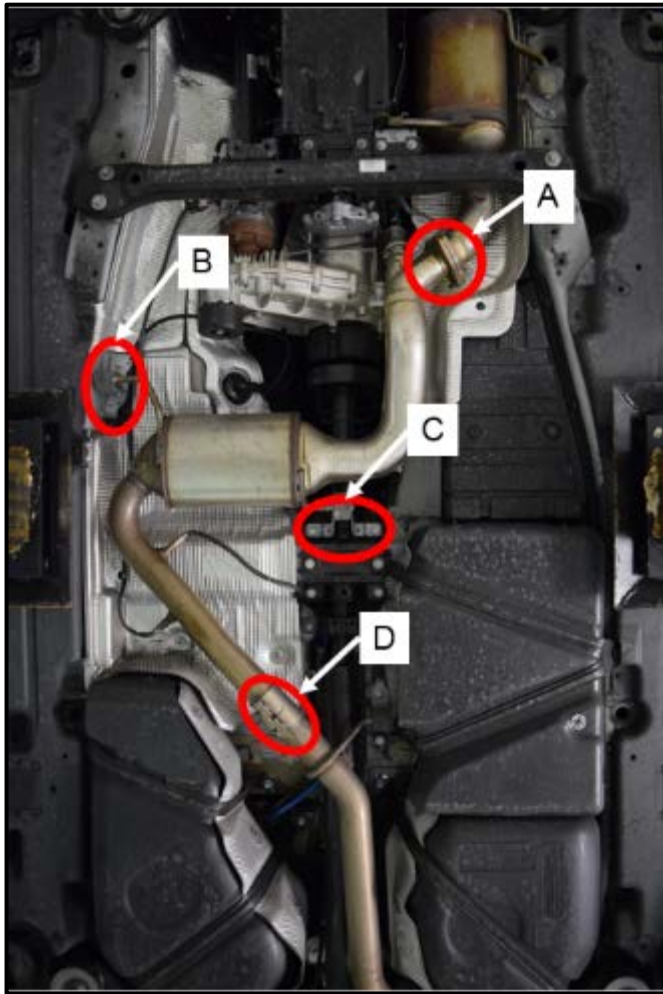

NOTE

Coat the threads on the nuts and exhaust studs/bolts <A> with hot bolt paste prior to installation. Refer to the Parts Catalog.

- Install the new exhaust Dual Clamp onto the exhaust pipe at location <D> and slide the clamp to the rear of the vehicle, but do not tighten.
- With the assistance of a second technician, install the new SCR Catalyst with a new gasket between the SCR Catalyst and DPF <A>. Fit the SCR Catalyst onto the DPF flange studs/bolts and install new nuts and tighten to 23 Nm.
- Slide the Dual Clamp into the installed position on the SCR Catalyst, but do not tighten. This will assist in holding the SCR Catalyst in place while the exhaust system is properly tensioned.
- Install the bolts for the SCR Catalyst brackets <B and C> and tighten by hand.

Part Number	Description	Qty.
7L8.254.400.RX	SCR Catalyst (2010 MY)	1
4L0.254.400.AX	SCR Catalyst (2012 MY)	1
1K0.253.141.J	Dual Clamp	1
7L5.253.115.C	Gasket	1
N 911.308.02	Shouldered Hex Nut	3
N 010.247.13	Replacement Stud/Bolt (if necessary)	3

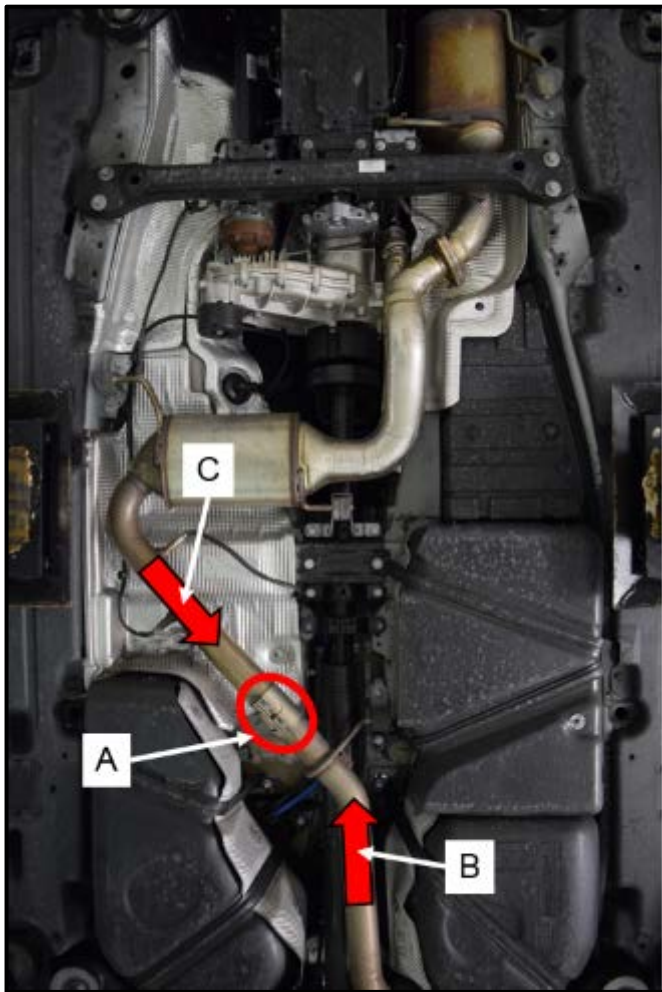

- Tighten the Dual Clamp <A> until there is a slight dragging resistance on both the SCR Catalyst pipe <arrow C> and the rear resonator/muffler pipe <arrow B>, but do not tighten so much that the pipes cannot slide in and out of the Dual Clamp <A>.
- Pretension the rear resonator/muffler hanging straps by pulling the rear resonator/muffler pipe towards the front of the vehicle <arrow B> and pulling the SCR Catalyst pipe towards the rear of the vehicle <arrow C>.

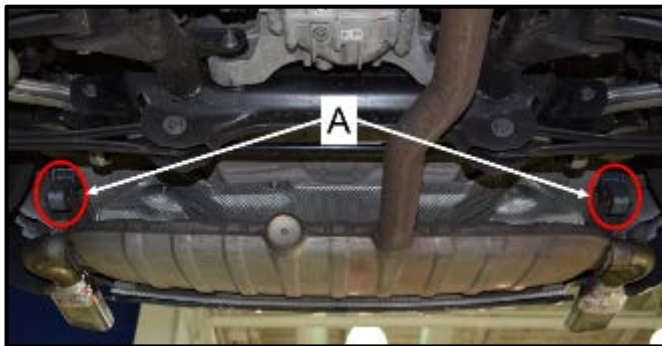

<A> = Rear Resonator Hanging Straps

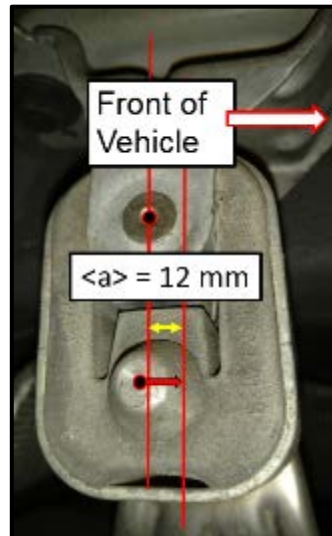

In order to reduce harmonic vibration, the rear muffler/resonator straps <A> require 12 mm of forward tension, as shown in the sub-photo. Pull forward on the rear muffler/resonator pipe and insert the pipe deeper into the Dual Clamp until this dimension is achieved.

- Once the desired dimension of <a> = 12 mm is achieved, tighten the Dual Clamp nuts to 23 Nm.

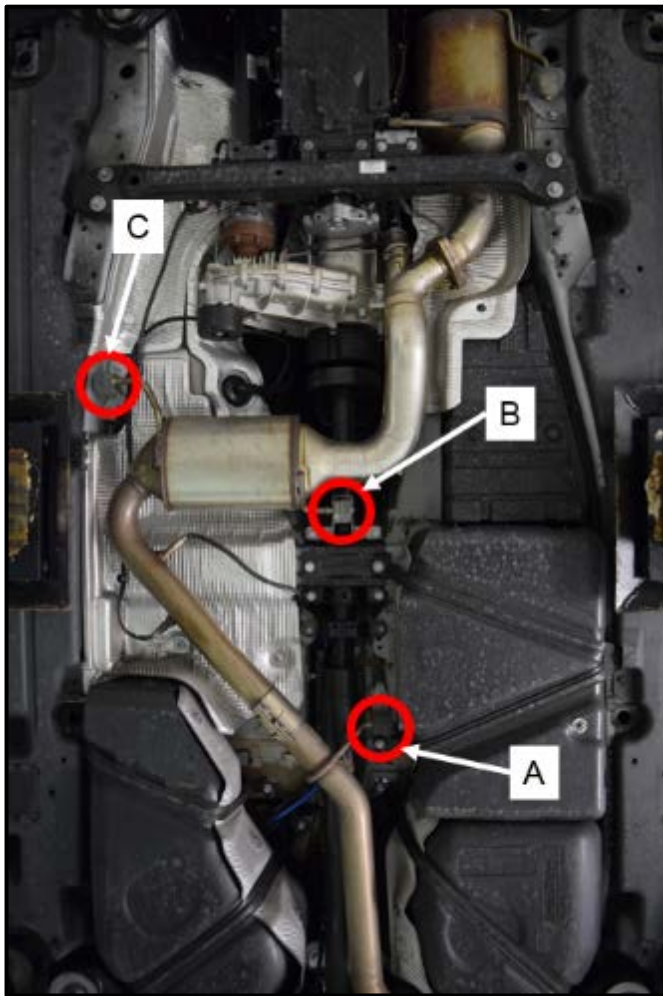
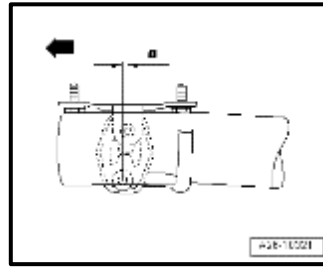

Figure <A>



Front Muffler/Resonator hanging strap: $\langle a \rangle = 4 \text{ mm}$

If equipped, loosen the bolts at the forward resonator pipe hanging strap <A> and adjust the bracket until $\langle a \rangle = 4 \text{ mm}$ of forward tension.

- Tighten the two hanging strap bolts to 23 Nm.

Figures <B and C>



Left and Right SCR hanging straps: $\langle a \rangle = 0.00 \text{ mm}$, install without tension.

If necessary, loosen the bolts at the left and right SCR Cat hanging straps <B and C> and adjust the brackets until $\langle a \rangle = 0.00 \text{ mm}$. The SCR Catalyst hanging straps are installed tension free.

- Tighten the two hanging strap bracket bolts to 60 Nm.
- Tighten the two hanging strap bracket bolts <C> to 23 Nm.

- Install threaded plug in the bung for the particle sensor and torque to 50 Nm.



Part Number	Description
WHT.003.487.A	Threaded plug

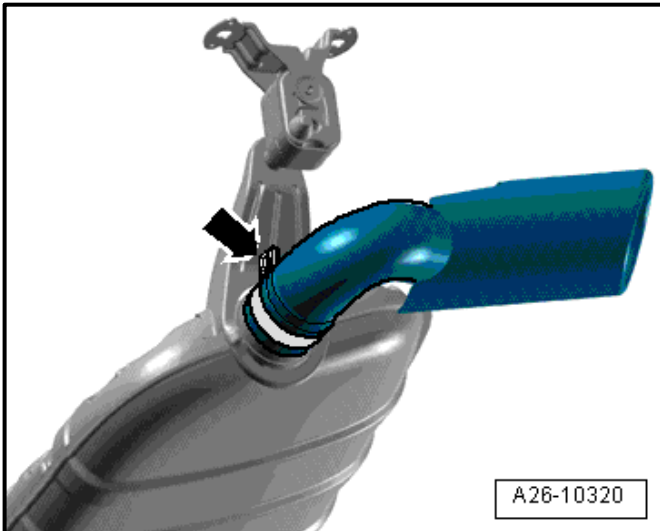

- If necessary, align the tail pipes by first loosening the screw-type clamp <arrow> on the tailpipes.

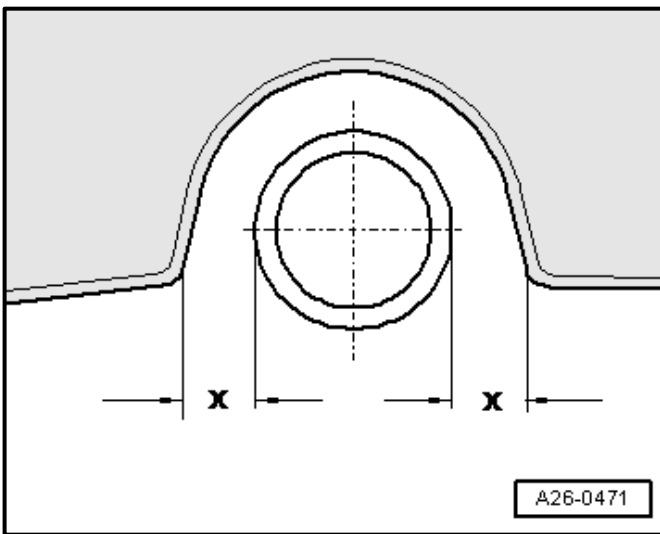

- Align tail pipe to the rear muffler and center the tail pipes into the bumper cover.
- Check distance of left and right tail pipes to bumper.
 - Dimension -x- left = dimension -x- right

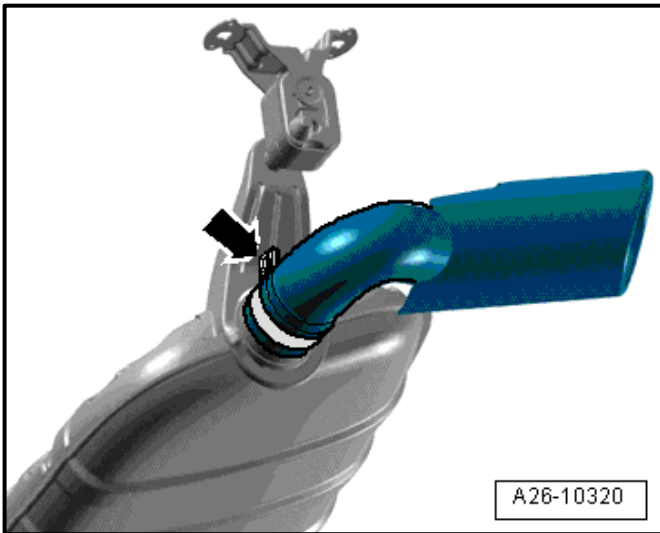

- Once the tail pipe is properly aligned to the bumper cover, tighten the screw-type clamps <arrow> to 60 Nm.



If reinstalling original Reducing Agent Injector:

- Install new gasket into the Reducing Agent Injector -N474-.
- Install the Reducing Agent Injector -N474- into the SCR Catalyst pipe ensuring that the tabs on the Injector <arrows> fit into the corresponding mounts in the SCR catalytic converter.
- Install a new retaining clamp <A> and tighten the bolt to 5 Nm.

Part Number	Description	Quantity
3C0.253.725	Retaining Clamp	1
3C0.253.115.A	Reducing Agent Injector Gasket (only if required)	1



All Work Complete.

Proceed to Section D.

Section D – Campaign Completion Stamp

I certify that this campaign has been performed in strict accordance with the applicable Audi repair procedure.

SAGA Code: _____

Technician: _____

Date: _____

Item#: AUD4927ENG

-OR-

Je certifie que cette campagne de rappel a été exécutée suivant les strictes directives de réparation d'Audi

Code de SAGA: _____

Technicien: _____

Date: _____

Item # AUD4927FRE

- Once the campaign has been completed, the technician should stamp the repair order.
- Stamps are available for ordering through the Compliance Label Ordering Portal.
- **Proceed to Section E**

Section E – Campaign Completion Label

Install Campaign Completion Label

- Fill out and affix Campaign Completion Label, part number CAMP 010 000, next to the vehicle emission control information label.

 **TIP**

Ensure Campaign Completion Label does not cover any existing label(s).

Proceed to Section F

Section F - Parts Return/Disposal



Parts Return/Disposal

SCR Catalyst:

- The SCR Catalyst must be tagged with a blue zip tie <as shown> and returned in order to be considered for core charge reimbursement.

All other parts:

- Properly store (retain), destroy or dispose of removed parts in accordance with all state and local requirements, unless otherwise indicated and/or requested through the Warranty Parts Portal (WPP).

All Work Complete

Proceed to Section G (California only).

Section G – California Only Requirements

CALIFORNIA ONLY Requirements for Emissions Campaigns Having Customer Notification

The California Air Resources Board and the Department of Motor Vehicles (DMV) require emissions-related campaigns to be completed prior to vehicle registration renewal. **When campaign work is done you must provide the owner with a signed “Vehicle Emission Recall – Proof of Correction” certificate (RC EMIS_CAL VW).** Certificates can be ordered at no cost online via the Compliance Label Ordering portal at www.accessaudi.com.

i TIP

Ensure owners are aware of the importance of retaining the completed certificate for their records. It should be mailed to the California DMV only upon request.