

<b>ADDRESSEES</b>	: ABC Customer Care and Parts Source
<b>VEHICLE MODEL</b>	: C2045 vehicles equipped with Iteris lane departure warning system
<b>MANUAL CHAPTER</b>	: 11.04 Control systems – Driver assistance systems
<b>DOCUMENT TYPE</b>	: <b>Informative</b>
<b>DATE</b>	: November 14 <sup>th</sup> , 2019
<b>SUBJECT</b>	: <b>To retrofit from Iteris to Wabco LDW2 lane departure warning system</b>

## INTRODUCTION

Van Hool has released a work procedure to assist ABC Companies in successfully retrofitting a C2045 vehicle factory equipped with an Iteris LDW system to a Wabco LDW2 system. The reason for this work procedure is the spare parts production stop for the Iteris LDW system.



Figure 1: Iteris lane-departure warning system camera



Figure 2: Wabco LDW2 lane-departure warning system camera

## PREPARATIONS

- Park the vehicle on a level floor.
- Apply the parking brake.
- Stop the engine.
- Switch off all systems and turn off the battery isolation switch on the dashboard.
- Put chocks in front of and behind the front-axle wheels.
- **Read the entire procedure before starting to work.**



### **WARNING!**

Observe safe shop practices at all times.

*Continued on next page.*

## **SPECIAL TOOLS, EQUIPMENT OR SERVICES:**

- LDW2 camera positioning tool: Van Hool caliper 11655152 (figure 17) or self-fabricated cardboard template (figure 18)
- Removal tool for MCP 2.8 connector terminal: VH10541368
- Removal tool for Junior Power Timer connector terminal: VH10906694

## **COMPONENTS AND PRODUCTS:**

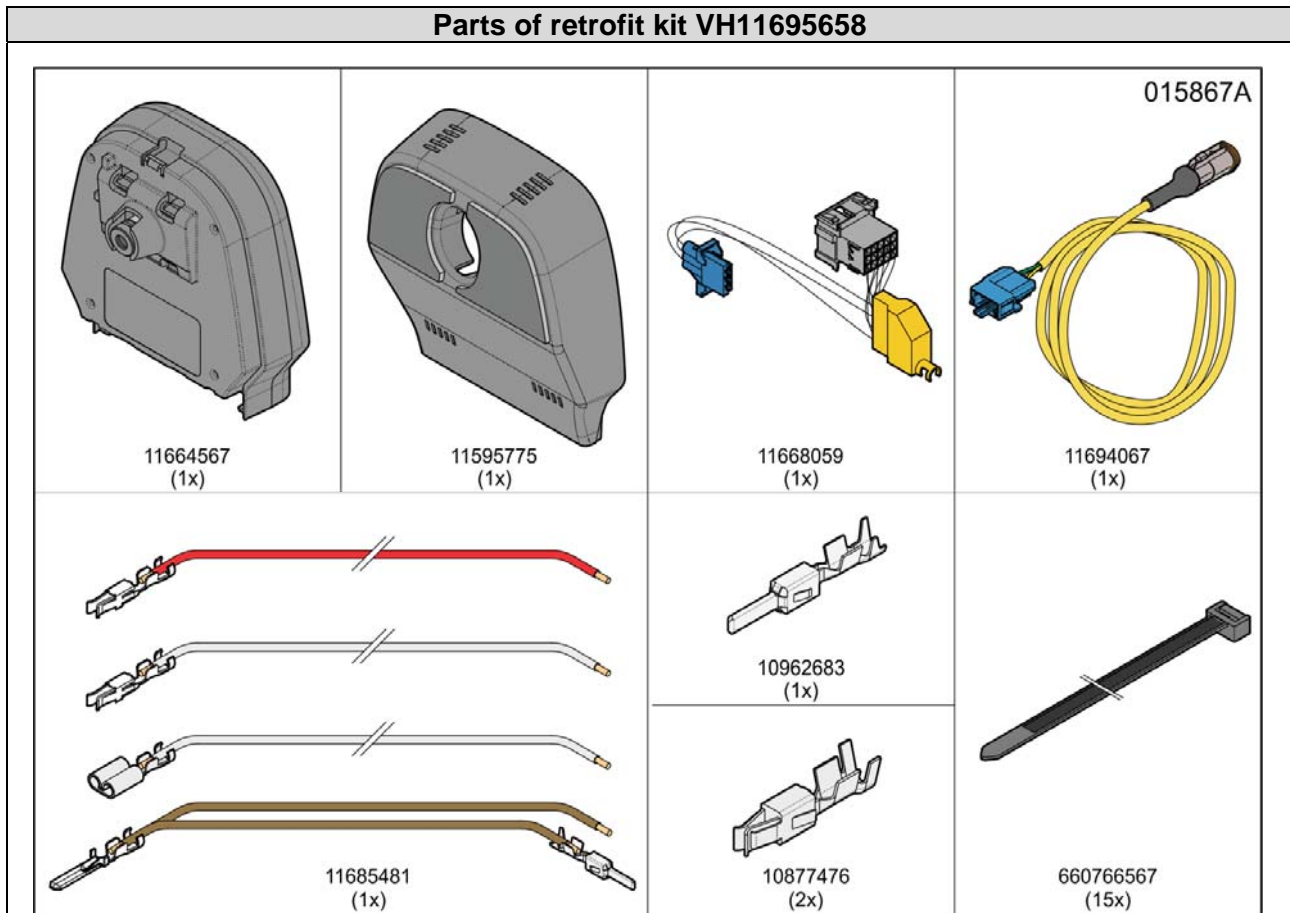

<b>VH reference</b>	<b>Description</b>	<b>Qty</b>
11664567	Wabco LDW2 camera (VH11626943) with parameters (VH11663172)	1
11595775	Camera support	1
11668059	Adapter cable	1
11694067	Supplementary adapter cable	1
11695481	Electric wire kit (red, 2x grey, brown)	1
10877476	Connector terminal, female	2
10962683	Connector terminal, male	1
660766567	Cable tie	15

*Continued on next page*

**PROCEDURE:**

Step	Action
1	Disconnect the connector socket from the Iteris camera.
2	Remove the Iteris camera from the windshield as described under "STEP 2 IN DETAIL".
3	Modify the vehicle wiring as described under "STEP 3 IN DETAIL".
4	Install the support of the Wabco LDW2 camera on the windshield as described under "STEP 4 IN DETAIL".
5	Secure the Wabco LDW2 camera into the support as described under "STEP 5 IN DETAIL".
6	Calibrate the Wabco LDW2 camera as described in work procedure WP984 "To calibrate LDW2 lane-departure warning system camera".
7	Register the works through the registration button located behind the work procedure on the Van Hool customer portal. Write the text "WP1134 completed on VIN..." in the "Remark" field.

End of procedure.

**STEP 2 IN DETAIL: To remove Iteris camera from windshield**

*NOTE: Use a spatula to remove the support. Any other tool, e.g. a screwdriver, might damage the windshield.*

Step	Action
2.1	Introduce a spatula between the glass and a corner of the support in order to detach the adhesive layer.
2.2	Starting in a corner, slowly detach the support from the glass by pulling.
2.3	Remove the remainders of glue on the windshield. This can be done easily by pulling the remainders of glue somewhat loose and rolling them with a finger.

**STEP 3 IN DETAIL: To modify vehicle wiring**

Step	Action
3.1	<b>At the right dashboard:</b> undo and remove the Torx screws securing the dash panel that holds the audio/video selector unit. Tilt the panel forwards so that the wiring behind can be reached.
3.2	<b>In the step well:</b> remove the trim panel to get access to the front junction box (EKF). <div style="text-align: right; margin-top: 10px;">  <p>Figure 4</p> </div>

Continued on next page

**3.3****At the connector socket disconnected from the Iteris camera:**

- a. Remove the connector terminal of contact number 15 by using removal tool VH10541368.
- b. Cut off the connector terminal and isolate the wire end with a heat shrink tubing.
- c. Introduce the female connector terminal of the red wire from the kit into contact number 7 of the connector socket.
- d. Take the grey wire with the female MCP 2.8 connector terminal from the kit and introduce the terminal into contact number 15 of the connector socket.
- e. Route the ends of both previous installed wires to the diagnostic panel (refer to figure 5) located in the front junction box EKF.
- f. Secure the wires on the way to other wiring with some cable ties from the kit.

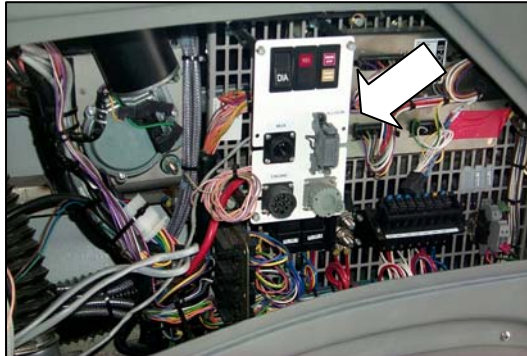
**Figure 5****3.4****At the dash panel that holds the audio/video selector unit:**

- a. Locate LDW dashboard switch S807 (refer to figures 6 and 7).
- b. Disconnect the connector socket from dashboard switch S807. Remove at the back of the connector socket the connector terminal of contact number 5. Cut off the connector terminal and isolate the wire end with a heat shrink tubing. Secure this red wire away with cable ties from the kit because it will not be reconnected.
- c. Take the other grey wire from the kit and introduce the female connector terminal into contact number 5 of switch S807 connector socket.
- d. Route the end of this grey wire also to the diagnostic panel located in the front junction box EKF.
- e. Secure the wire on the way with some cable ties from the kit.

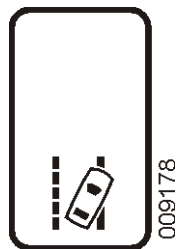
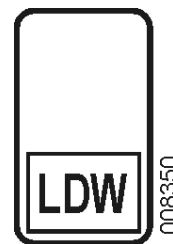
**Figure 6****Figure 7***Continued on next page*

<p><b>3.5</b></p>	<p>Connect adapter cable 11668059 from the kit as follows:</p> <ol style="list-style-type: none"> <li>Connect the 15-pin connector plug of the adapter cable to the connector socket disconnected in step 1.</li> <li>Route the blue 3-pin connector socket of the adapter cable to the front junction box EKF. Remove the existing cable tail connecting the LDW camera to the CAN bus. Connect the blue 3-pin connector socket by using supplementary adapter cable 11694067 from the kit to the Deutsch Y-splitter CAN bus connector.</li> <li>Route the remaining 16-pin connector socket of the adapter cable to the new camera location.</li> <li>Secure the wires on the way with some cable ties from the kit.</li> </ol>
<p><b>3.6</b></p>	<p><b>In the front junction box (EKF):</b></p> <ol style="list-style-type: none"> <li>Locate the black 22-pin Junior Power Timer connector P104.</li> <li>Disconnect the connector socket by first depressing the locking tab and then separating it from the connector plug. Fold the connector socket side cover open.</li> <li>Remove the connector terminal of contact number 5 from the connector socket by using removal tool VH10906694 and cut the terminal off.</li> <li>Strip back the violet electric wire as well as both grey electric wires earlier installed over a distance of 7,5 mm (0.29 inch).</li> <li>Crimp female connector terminal 10877476 from the kit to the wires and reintroduce it into contact 5 of connector socket P104.</li> <li>Close the connector socket side.</li> <li>Reconnect connector P104.</li> <li>Secure the wires on the way to other wiring with some cable ties from the kit.</li> </ol> <div data-bbox="501 1003 1037 1361" data-label="Image"> </div> <p><b>Figure 8: Location of connectors P102 and P104</b></p>
<p><b>3.7</b></p>	<p><b>In the front junction box (EKF):</b></p> <ol style="list-style-type: none"> <li>Locate the black 22-pin Junior Power Timer connector P102 (refer to figure 8).</li> <li>Disconnect the connector socket by first depressing the locking tab and then separating it from the connector plug. Fold the connector socket side cover open.</li> <li>Remove the connector terminal of contact number 3 from the connector socket by using removal tool VH10906694 and cut the terminal off.</li> <li>Strip back the white electric wire and the red wire earlier installed over a distance of 7,5 mm (0.29 inch).</li> <li>Crimp the other connector terminal 10877476 from the kit to the wires and reintroduce it into contact 3 of connector socket P102.</li> <li>Close the connector socket side.</li> <li>Reconnect connector P102.</li> <li>Secure the wires on the way to other wiring with some cable ties from the kit.</li> </ol>

*Continued on next page*

**3.8****In the main junction box (EKV):**

- a. Locate the white 12-pin connector P107.
- b. Unlock and disconnect the connector.
- c. **At the connector plug:** unlock the secondary locking device. Remove the connector terminals of contact numbers 3, 4, 5, 6, 7 and 8. Cut off the terminal of contact number 3. Isolate the red wire end of contact number 3 with a heat shrink tubing. Discard the cable bridge connecting contact numbers 3, 4, 5, 6, 7 and 8.
- d. **At the connector plug:** remove the connector terminal of contact number 9. Cut off the terminal of contact 9. Strip back the brown wire over a distance of 7,5 mm (0.29 inch). Take the preassembled brown wire from the kit and strip back the wire end without connector terminal over a distance of 7,5 mm (0.29 inch). Crimp both brown wires together with connector terminal 10962683 from the kit. Introduce the terminal into contact number 9. Introduce the two other connector terminals of the preassembled brown wire into contact number 5 and 6. Relock the secondary locking device of the connector plug.
- e. Reconnect connector P107.
- f. Secure the wires on the way to other wiring with some cable ties from the kit.

*Continued on next page*

**STEP 5 IN DETAIL:** To install new support of lane-departure warning system camera on windshield

*NOTE: Never reuse a removed support! The support has inevitably been deformed at removal. Discard the used support according to the locally applicable guidelines regarding protection of the environment.*

*NOTE: To position the lane-departure warning system camera properly on the windshield, you have to use a self-fabricated template (refer to figure 16 for the dimensions) or caliper VH11655152 (refer to figure 17).*

*NOTE: The support of the lane-departure warning camera is provided with a special adhesive layer with limited storage life. The mounting expiry date is mentioned on an adhesive label on the support (see figures 9 and 10). Never install a support of which the expiry date has elapsed.*



Figure 9: Location of adhesive label with expiry date on support





Figure 10: Mounting expiry date of support of lane-departure warning system (typical: February 2018)

Step	Action
5.1	Thoroughly clean the mounting area of the camera on the windshield. To this end, use a mix of 50% demineralized water and 50% isopropyl alcohol.
5.2	Manufacture a template from a strong piece of cardboard to position the lane-departure warning system camera. Use the dimensions from figure 17 to manufacture the template.
5.3	On the interior side of the windshield, tape the template onto the windshield. Make sure that the bottom and the non-chamfered side of the template fit tightly against the windshield rubbers.
5.4	<p>Remove the protective film from the adhesive layer and glue the support onto the windshield as indicated in figure 12.</p> <div style="display: flex; justify-content: space-around;"> <div data-bbox="328 1514 855 1899"> <p>Figure 11: To remove protective film from adhesive layer</p> </div> <div data-bbox="896 1514 1423 1899"> <p>Figure 12: To glue support onto windscreen</p> </div> </div>

*Continued on next page*

5.5	By hand, press the support against the windshield for at least 5 seconds. This activates the adhesive layer. Repeat this at different places over the area with adhesive layer.
5.6	Check from the outside whether the adhesive layer is adequately glued to the windshield all over. A single bubble is no problem, but the adhesive layer should be glued to the windshield for at least 3/4 of its surface. Press the support some more from inside if necessary.
5.7	<p><i>NOTE: After 20 minutes, the adhesive layer reaches 50% of its adhesive force. Full adhesive force is only obtained after a couple of hours.</i></p> <p>Let the adhesive layer rest for approximately 20 minutes before continuing the installation procedure of the lane-departure warning system camera.</p>

**STEP 6 IN DETAIL: To secure lane-departure warning camera into support**

Step	Action
6.1	Connect the new camera to the vehicle wiring.
6.2	Remove, if present, the protective cap from the lens. Do not touch the camera lens with your fingers! The slightest finger print or dust on the lens can cause incorrect warnings of the lane-departure warning system.
6.3	<p>Starting at the bottom, install the camera in the support (refer to figure 13). Then press the top in the support until you hear a click (refer to figure 14). The camera is now secured in the support.</p> <div style="display: flex; justify-content: space-around;"> <div data-bbox="317 990 845 1375">  <p>Figure 13</p> </div> <div data-bbox="874 990 1404 1375">  <p>Figure 14</p> </div> </div>
6.4	<p>Check whether the camera is introduced equally far into the support all round. The camera is properly installed if the seam is equal all round.</p> <div style="text-align: center;">  <p>Figure 15</p> </div>

Continued on next page

**TEMPLATE/CALIPER TO POSITION LDW2 CAMERA ON WINDSHIELD**

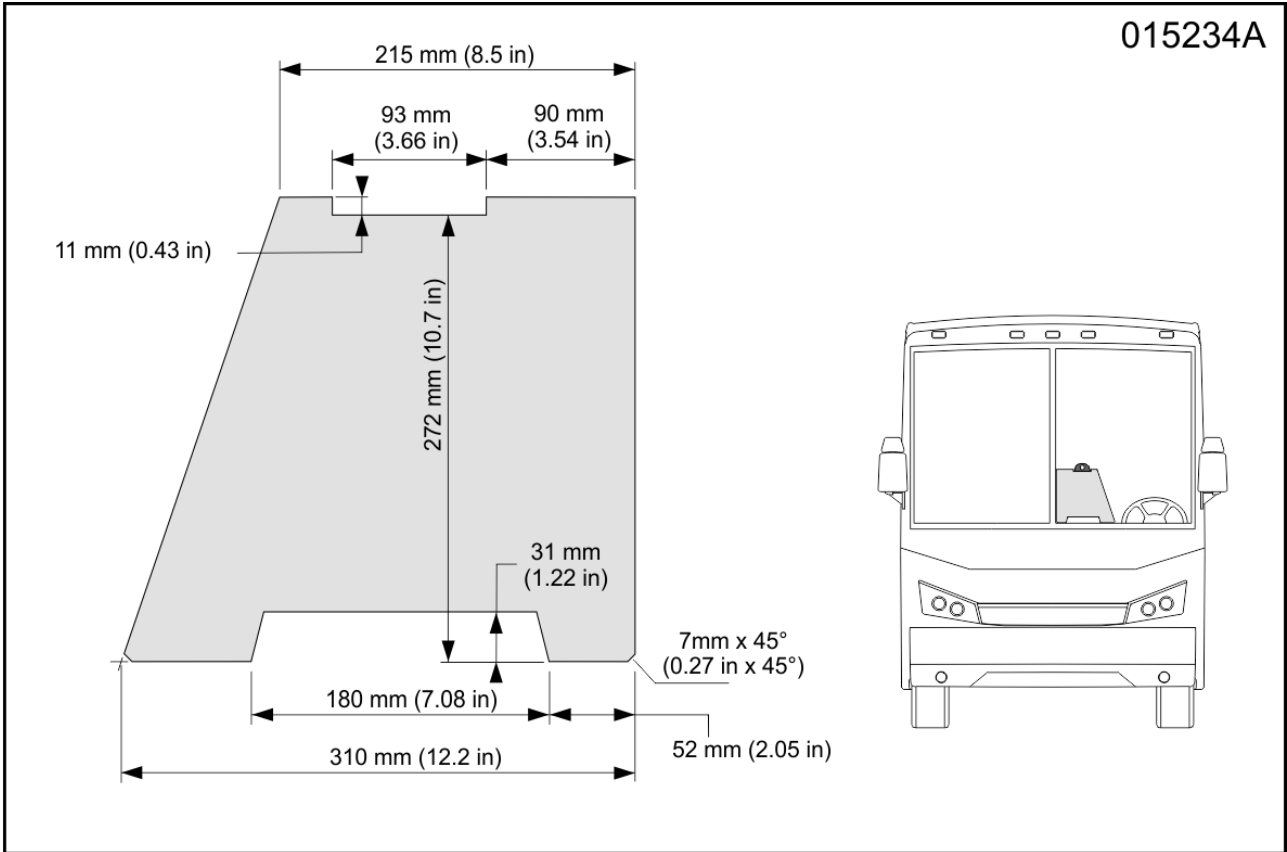

**Figure 16: Dimensions of self-fabricated cardboard template to position the LDW2 camera at the inside of the windshield**

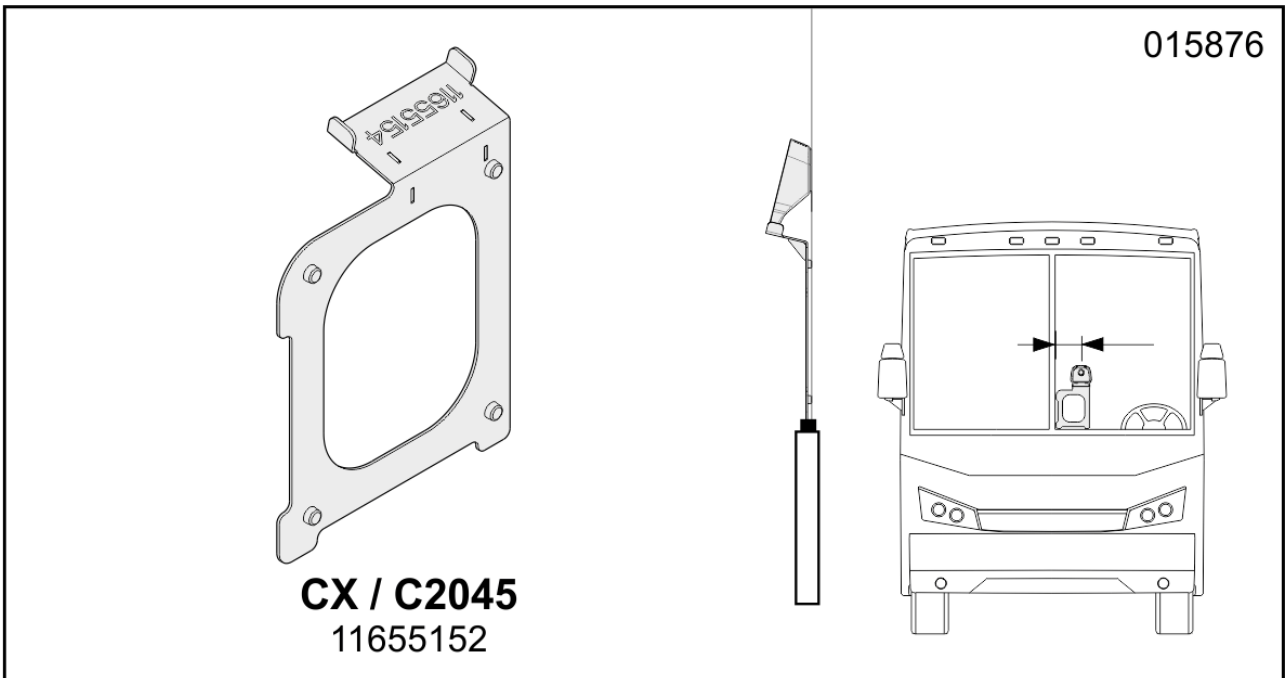

**Figure 17: Caliper VH11655152 to position LDW2 camera at the inside of the windshield**

*Continued on next page*

## **DISCLAIMER:**

The procedures contained herein are not exclusive. Van Hool cannot possibly know, evaluate, or advise the transportation industry of all conceivable ways in which a procedure may be undertaken or of the possible consequences of each such procedure. Other procedures may be as good, or better, depending upon the particular circumstances involved. Each carrier who uses the procedures herein must first satisfy himself thoroughly that neither the safety of his employees or agents, nor the safety or usefulness of any products, will be jeopardized by any procedure selected.

## **VAN HOOL CUSTOMER PORTAL:**

Consult the customer portal regularly for the latest service documentation. In addition to the maintenance manual, you will also find the operating manual and the spare parts catalogue of your vehicle on the customer portal. The customer portal is accessible through [www.vanhool.be](http://www.vanhool.be), and only with a code (password) from Van Hool. If you do not have a password yet, request it by using the link on the Van Hool website.

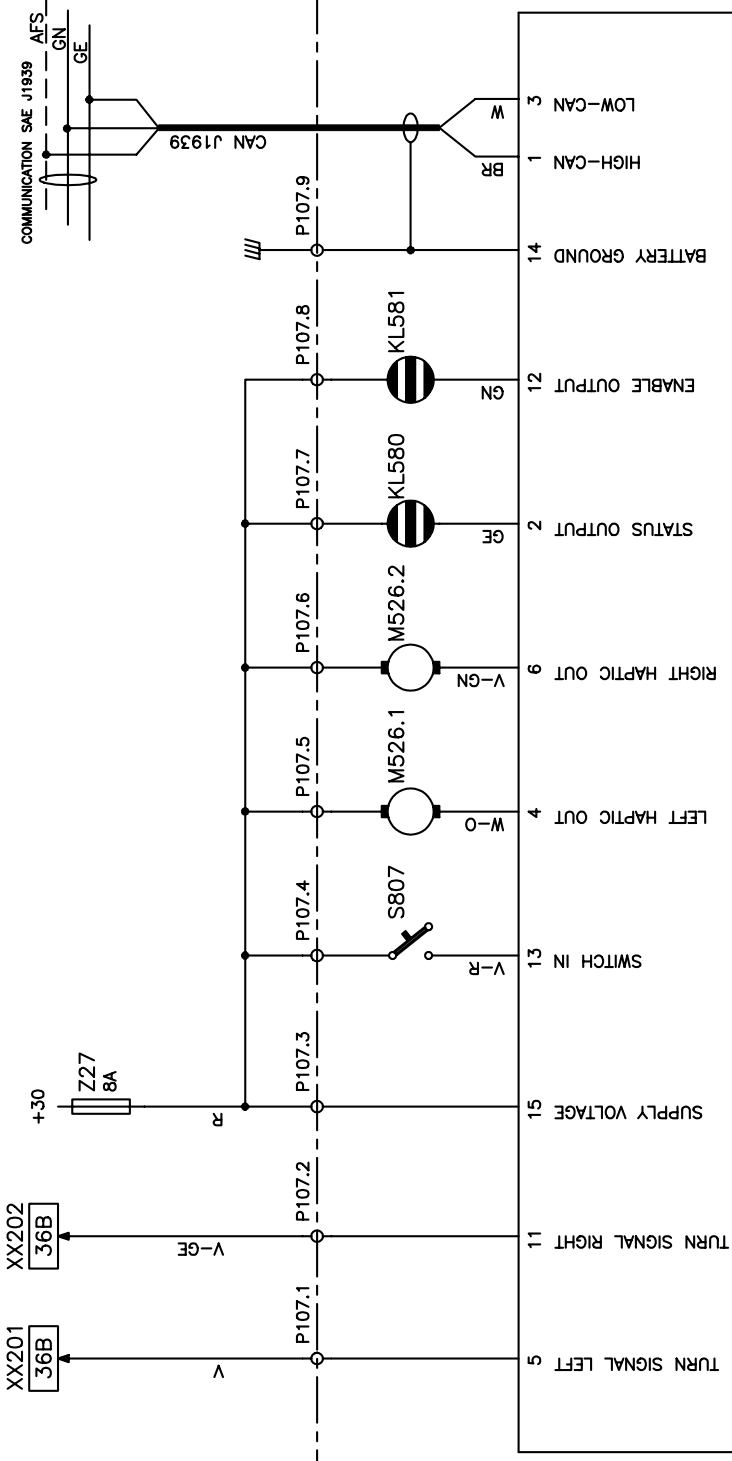

**LANE DEPARTURE WARNING**

Gebnr. **CX45 USA**

C					
B					
A	CAN VERBINDING LAY-OUT.		WDH	7	30-08-2013
VERSIE	WIJZIGINGEN		GET	VISUM	DATUM
I S O SYMBOL	NAAM	DATUM	LAS VERBINDINGEN EN VERBODEN TOEGANG VOOR ALLEN NIET OORDEELDELIJK EN NIET AANGEGUID. NIET AANGEGUID. VOLGENS VAN HOOL NORMEN		
18-12-2012					
GET	WDH	1/1			
VISUM	DN				
LANE DEPARTURE WARNING		PSNR / TREFW	60 19R / R431		
ASSISTENTE DE CAMIL		CODE	B 2500 LIER		
		VH NUMMER	FORM GS MS		
			11342557/3/ -		



