



Service Bulletin

Bulletin No.: 19-NA-103

Date: October, 2019

TECHNICAL

Subject: Intermittent Click Noise at Front of Vehicle, ABS, Traction Control System (TCS)/ Stabilitrak Lamps May Illuminate Intermittently and/or Deactivate for Ignition Cycle, DTC P0721, P215B, C0500-C0504 and/or C0506-C050A Set

Brand:	Model:	Model Year:		VIN:		Engine:	Transmission:
		from	to	from	to		
Chevrolet	Volt	2016	2019				

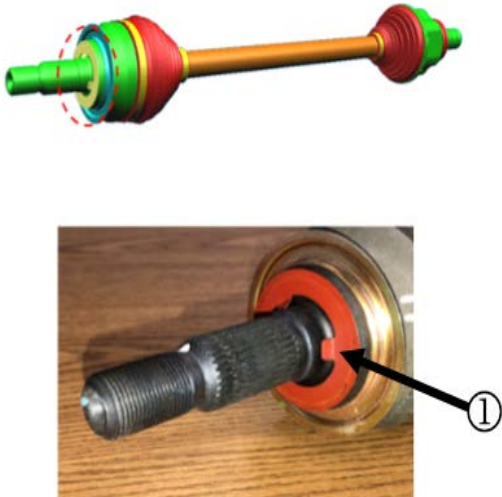
Involved Region or Country	North America, Europe, GM Korea Company		
Condition	<p>Some customers may comment on hearing an intermittent click noise in the front of vehicle. The ABS, TCS/Stabilitrak system lamps may also illuminate intermittently and those systems may be deactivated/shut off for that ignition cycle.</p> <p>Technicians may find one, or more, of the following DTCs set: P0721, P215B, C0500-C0504, C0506-C050A.</p>		
Cause			
Correction	<p>Upon verifying the condition, remove and discard the anti-click washer on the affected half shaft(s), then inspect the wheel speed sensor on that side(s). Follow the recommended steps in the Service Procedure below.</p>		

5317523

Service Procedure

Antilock Brake System

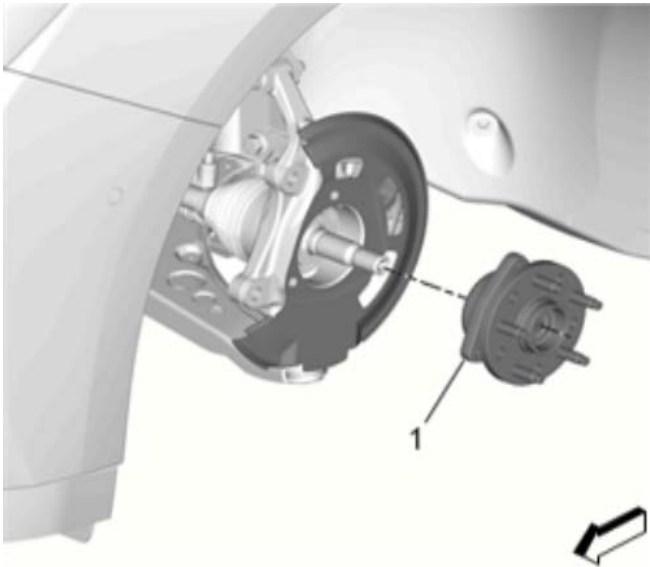

5317526

Note: In cases where the condition is verified on both sides of the vehicle, remove the anti-click washer from BOTH sides.

1. Remove the front wheel bearing and hub assembly (1) from the vehicle, on the affected side. Refer to *Front Wheel Bearing and Hub Replacement* in SI.

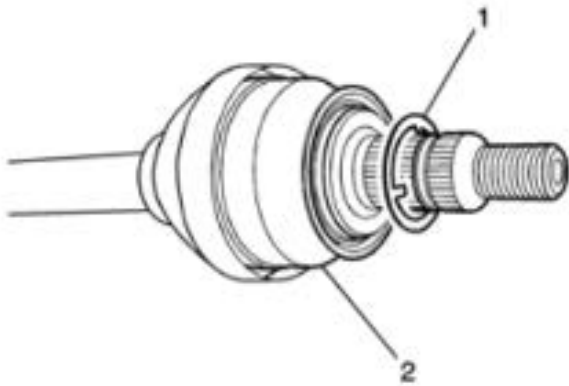

5317528

Important: DO NOT install any anti-click washer.

2. Remove the anti-click washer (1) from the outboard joint of the half shaft (2) and discard.
3. If affected, repeat steps #1 and #2 on the opposite side.

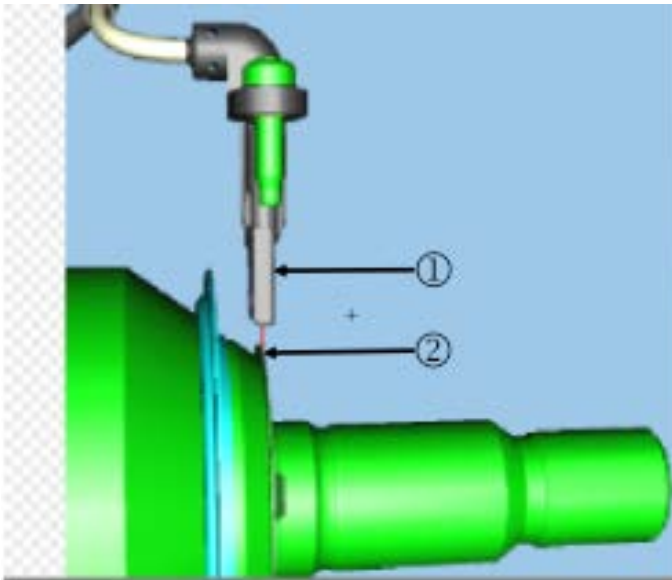

5317529

Note: As shown in the above illustration, the wheel speed sensor (WSS) (1) is directly in-line with the anti-click washer (2) on the outboard joint of the half shaft.

4. **Before reinstalling the bearing/hub**, inspect the WSS on either/both affected side(s) for possible damage. It may be damaged due to contact with the oversized damaged washer.

Important: Once removed, the drive shaft nut cannot be reused. Follow the recommendations in SI for this and any other fastener replacement.

- If no damage is found, reinstall the front wheel bearing and hub assembly, and no further repairs are necessary. Refer to *Front Wheel Bearing and Hub Replacement* in SI.
- If the WSS is found to be damaged (as shown circled in the graphic above), continue ahead to step # 5 and replace the WSS.

5. Replace any damaged front WSS (2). Refer to *Front Wheel Speed Sensor Replacement* in SI.

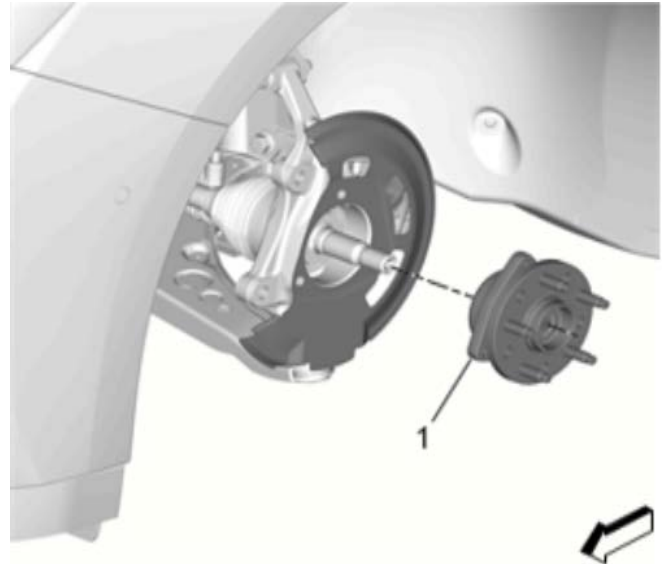

5317526

6. Reinstall the front wheel bearing and hub assembly (1). Refer to *Front Wheel Bearing and Hub Replacement* in SI.

Parts Information

Use the vehicle identification number (VIN), SI, and the GM Electronic Parts Catalog to determine the proper part to order.

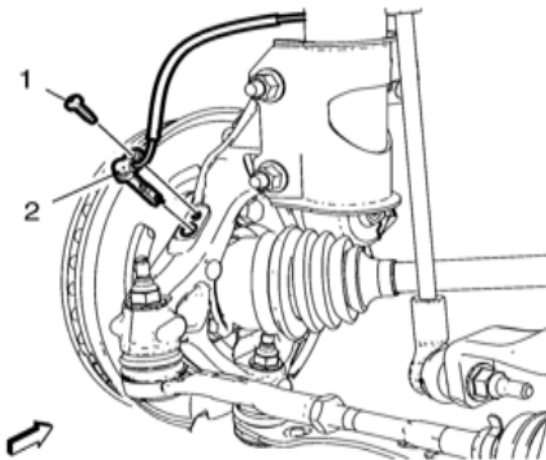

5317532

Causal Part	Description	Part Number	Qty
	SENSOR ASM-FRT WHL SPD (2016-2018)	39002172	1, or 2, if required.
	SENSOR ASM-FRT WHL SPD (2019)	39124497	

Warranty Information

For vehicles repaired under the Powertrain coverage, use the following labor operation. Reference the Applicable Warranties section of Investigate Vehicle History (IVH) for coverage information.

Labor Operation	Description	Labor Time
8080458*	Remove Anti-click Washer (one side)	0.9 hr
Add	Replace WSS (one side)	0.7 hr
Add	Remove Anti-click Washer (other side)	0.8 hr
Add	Replace WSS (other side)	0.6 hr

*This is a unique Labor Operation for Bulletin use only.

Version	2
Modified	Released May 09, 2019 October 09, 2019 – Added DTCs to the Subject and Condition and updated the Involved Regions or Country.

