



Service Bulletin

Bulletin No.: 18-NA-069

Date: November, 2019

TECHNICAL

Subject: Poor Engine Performance in Extremely Cold Weather Conditions for LFV Engines, Charge Air Cooler Icing - Malfunction Indicator Lamp (MIL) Illuminated, DTC P0299, P0236, P2227, P00C7 Set

Brand:	Model:	Model Year:		VIN:		Engine:	Transmission:
		from	to	from	to		
Chevrolet	Malibu	2016	2019			1.5L (LFV)	

Involved Region or Country	North America and China
Condition	<p>Some customers may comment on one or more of the following conditions when driving in extremely cold weather conditions (-18°C or less / 0°F or less):</p> <ul style="list-style-type: none"> • Loss of power • Hesitation on acceleration • Stalling condition • MIL Illuminated <p>The technician may find one or more of the following DTCs set:</p> <ul style="list-style-type: none"> • P0299 • P0236 • P2227 • P00C7
Cause	This condition may be caused by ice accumulation in the charge air cooler (CAC), restricting air flow.
Correction	<p>If any of the above conditions are present, allow time for possible ice build up in the CAC to melt by allowing the vehicle to thaw in a warm climate.</p> <p>If any of the above conditions are validated to be caused by freezing/icing, replace the CAC.</p> <p>If not previously performed, an oil change may be necessary to remove any moisture from the engine.</p>

Service Procedure

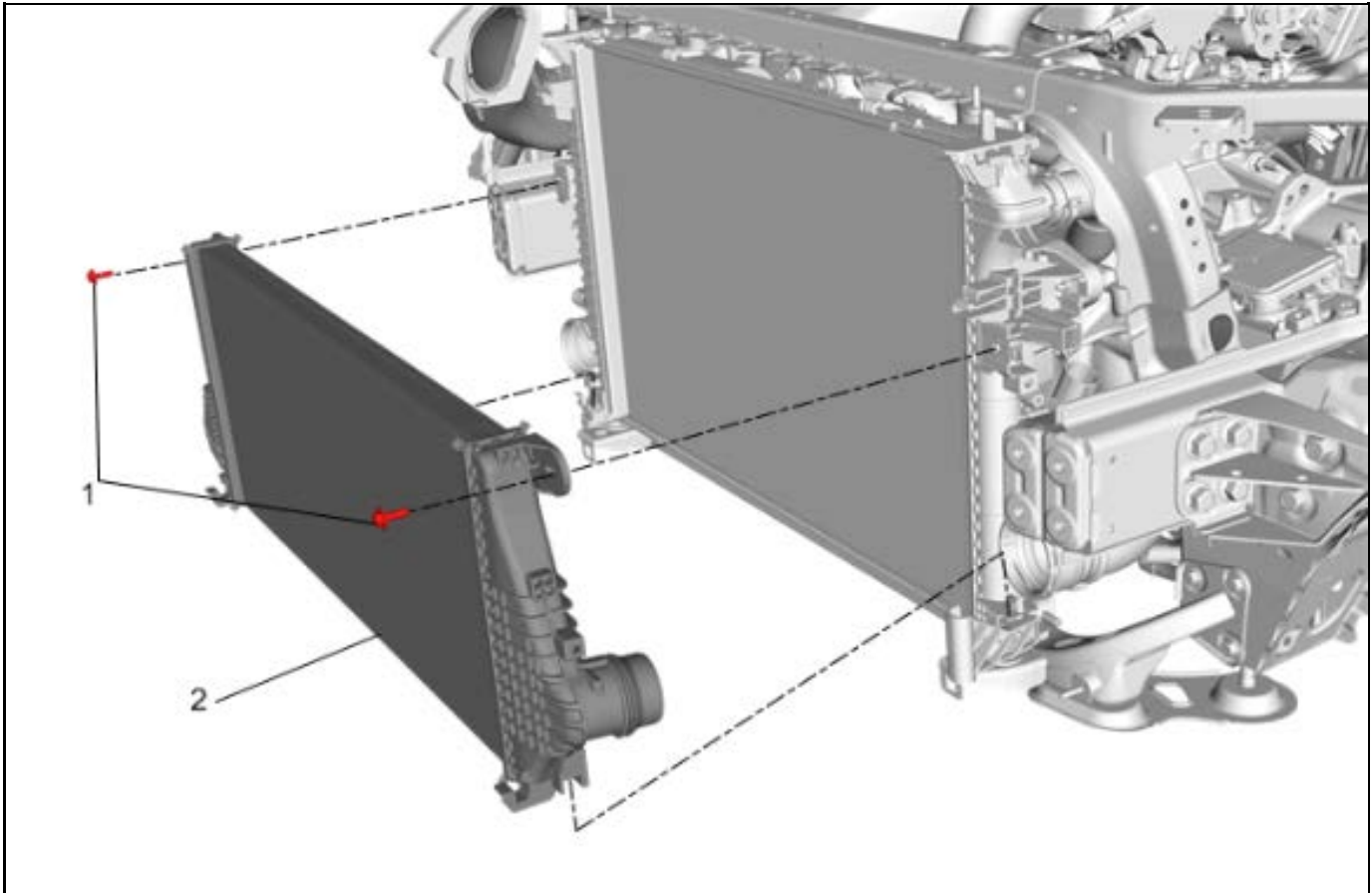

4241877

1. Install the CAC (2). Refer to *Charge Air Cooler Replacement* in SI.

Important: Do Not perform an oil change if the oil change was recently done.

- If the oil change was recently done and no signs of moisture have been confirmed, proceed to step 3.
 - If the oil change was not previously done or moisture has been found in the oil, proceed with procedure.
2. If required, perform an oil change. Refer to *Engine Oil and Oil Filter Replacement* in SI.

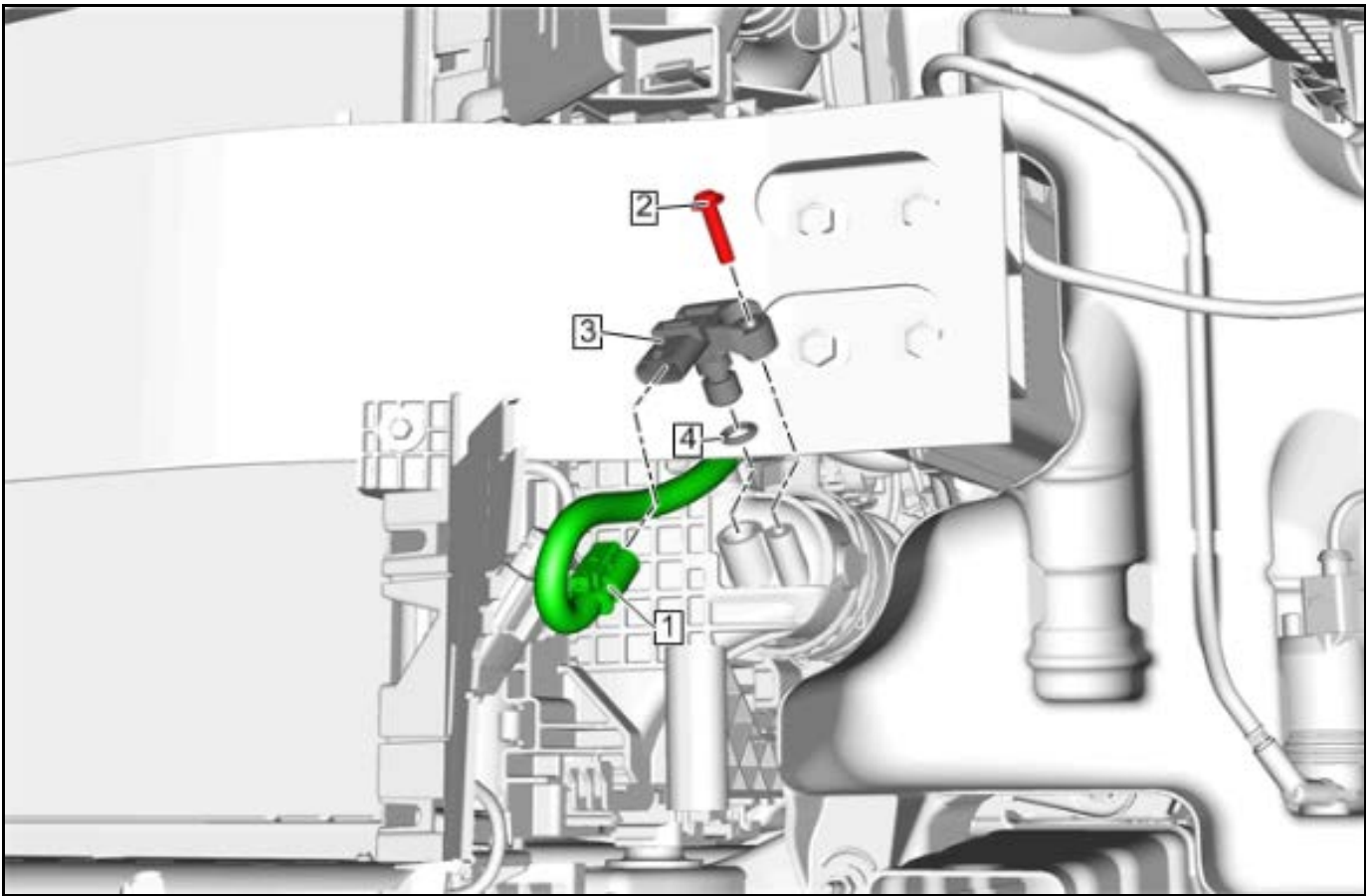

4233269

3. Remove the Turbocharger Air Pressure sensor (3). Refer to *Turbocharger Air Pressure Sensor Replacement* in SI.



4910683



5020216

Important: Due to the sensitivity of the sensor, **Do Not** use any chemical cleaners including water and **Do Not** use compressed air to remove contaminants.

4. Inspect the sensor of any contaminants.

5. Allow time for any ice build-up to melt by placing the sensor port down.
6. Clean the sensor with a clean towel.
7. Install the sensor.

Parts Information

Description	Part Number	Qty
COOLER ASM-CHRG AIR	84768953	1
Filter, Oil	Refer to the Electronic Parts Catalog (EPC).	
Oil		

Warranty Information

For vehicles repaired under the Emission coverage, use the following labor operation. Reference the Applicable Warranties section of Investigate Vehicle History (IVH) for coverage information.

Labor Operation	Description	Labor Time
4086058*	Charge Air Cooler Replacement	2.6 hrs
Add	IAPT Inspection	0.2 hr
Add	Oil Change	0.3 hr

*This is a unique Labor Operation for bulletin use only.

Version	3
Modified	Released March 05, 2018 January 24, 2019 – Added the 2019 Model Year, China to Involved Region or Country, updated the Service Procedure and Warranty Information. October 28, 2019 – Updated the Part Number in the Parts Information.

