

FLA COE
 FLB COE
 FLD Conventional
 Business Class
 FLC 112 Conventional

Century Class Conventional
 > Argosy
 Cargo
 Columbia
 > 122SD and Coronado

Business Class M2
 Cascadia
 108SD/114SD
 New Cascadia

**Freightliner
 Service Bulletin**

Description of Revisions: This bulletin replaces the version dated 09/27/2019. This bulletin now includes the Argosy.

General Information

Beginning 10/29/18 the 122SD and Coronado cab doors were updated to a new style regulator and window. Beginning 09/2011, the Argosy cab doors were also updated to the same new style regulator and window. When replacing an older style regulator or window the vehicle must be retrofitted to the new style regulator and window.

To replace the old style window regulator and glass window, the interior trim panel, inner door panel, and regulator and window glass must first be removed. Then three new holes need to be drilled to attach the new style of regulator.

Parts

Parts are available from the PDCs. See the appropriate table, based on if you're replacing the regulator and glass for the left-hand or right hand door, for required parts.

Parts Required—LH Door		
Item Description	Part Number	Qty
LH Window Regulator	A18-71307-000	1
Jumper Harness	A66-14820-000	1
LH Door Glass	18-71309-000	1
Screws, M6x1.00	23-12930-712	2
Nut, M6x1.00	913023 006002	1

Table 1, Parts Required—LH Door

Parts Required—RH Door		
Item Description	Part Number	Qty
RH Window Regulator	A18-71307-001	1
Jumper Harness	A66-14820-000	1
RH Door Glass	18-71309-001	1
Screws, M6x1.00	23-12930-712	2
Nut, M6x1.00	913023 006002	1

Table 2, Parts Required—RH Door

Window Regulator Retrofit Instructions

Trim Panel Removal

1. Park the vehicle, shut down the engine, and apply the parking brakes. Chock the tires.
2. Pull up the door seal from the interior trim panel. It is not necessary to remove the door seal entirely, just enough to remove the trim panel. See [Fig. 1](#).

**Freightliner
Service Bulletin**

FLA COE
FLB COE
FLD Conventional
Business Class
FLC 112 Conventional

Century Class Conventional
> Argosy
Cargo
Columbia
> 122SD and Coronado

Business Class M2
Cascadia
108SD/114SD
New Cascadia

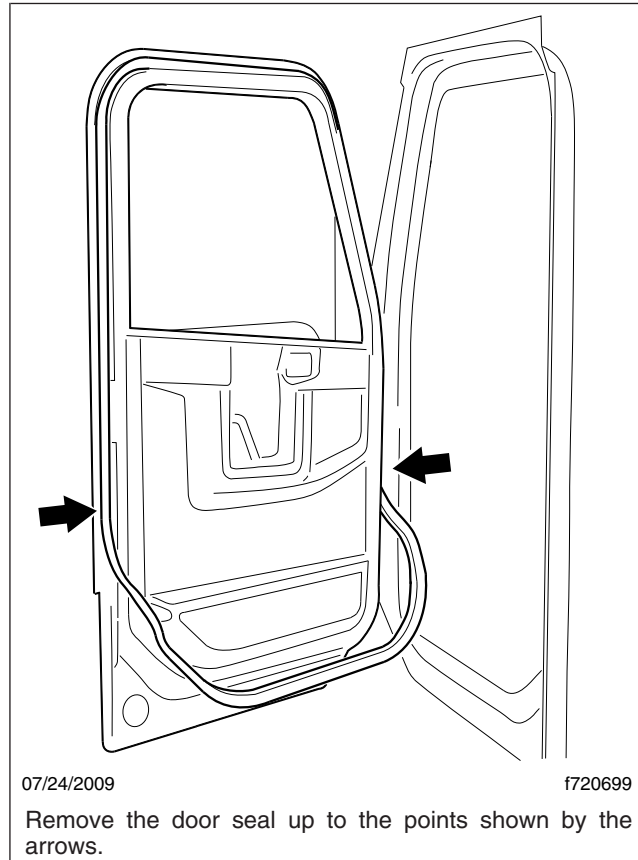

Fig. 1, Door Seal Partially Removed

3. Remove the two screws that secure the door grab handle, then remove the grab handle.
4. Loosen the screw that secures the interior door release handle then remove the release handle.
5. Snap the courtesy light out from underneath the map pocket, then disconnect it from the door wiring.
6. Remove the six screws that attach the map pocket to the trim panel, then remove the map pocket.
7. Remove the five screws that attach the bottom portion of the trim panel to the inner door.
8. Pull the top portion of the trim panel loose from the backside clips that secure it to the inner door.
9. Disconnect the switch wiring.
10. Remove the switch bezel and switch assembly.
11. Lift the trim panel over the lock knob and set it aside.

Inner Door Panel and Window Glass Removal

1. Remove the vapor barrier from the central access opening of the inner door panel.
2. On the outside of the door, remove the screw from the lower mirror mount cover then remove the cover.
See [Fig. 2](#).

FLA COE
FLB COE
FLD Conventional
Business Class
FLC 112 Conventional

Century Class Conventional
> Argosy
Cargo
Columbia
> 122SD and Coronado

Business Class M2
Cascadia
108SD/114SD
New Cascadia

Freightliner
Service Bulletin

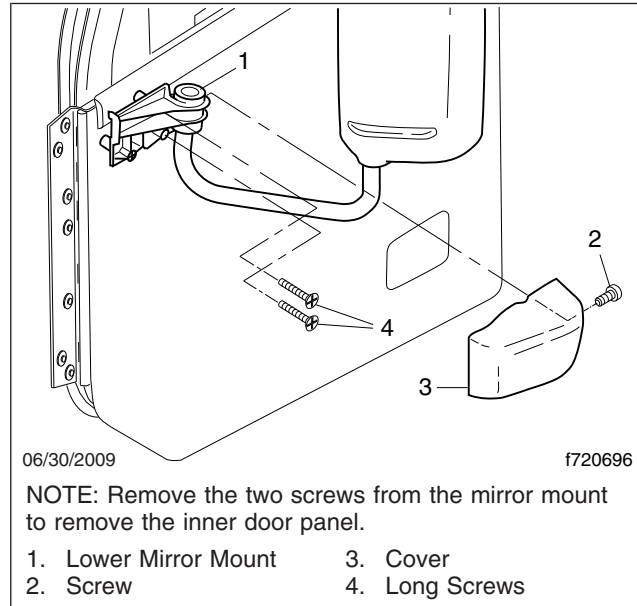

Fig. 2, Lower Mirror Cover

3. Disconnect the mirror wiring connectors and antenna cable, then push the connectors through the opening inside the door.
4. Remove the two long aft screws that secure the lower mirror mount and inner door panel to the door. See [Fig. 2](#).
5. Remove most of the screws that attach the inner door panel to the door frame assembly, leaving a few in loosely to hold the panel on.
6. Remove the screw that attaches the lower glass run tab to the inner door panel. This screw is located forward of the central door opening on the inner door panel.
7. Disconnect the door lock rod from the exterior door handle mechanism and the door lock actuator and disconnect the interior handle rod from the door lock actuator. These are accessible through a hole in the lower aft portion of the inner door panel. See [Fig. 3](#).

Freightliner Service Bulletin

FLA COE
FLB COE
FLD Conventional
Business Class
FLC 112 Conventional

Century Class Conventional
> Argosy
Cargo
Columbia
> 122SD and Coronado

Business Class M2
Cascadia
108SD/114SD
New Cascadia

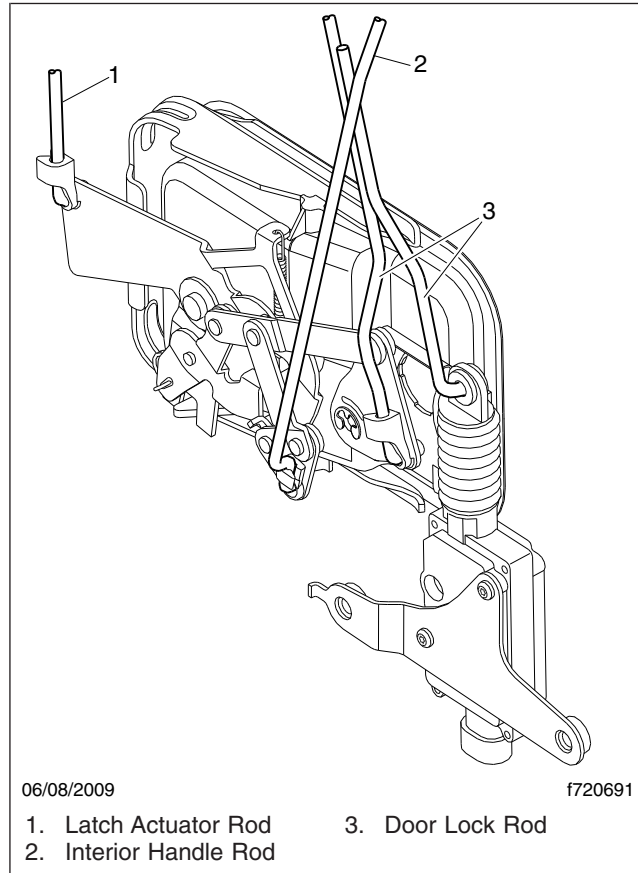

Fig. 3, Exterior Door Handle (inside view)

8. Remove the three screws that secure the tread plate then remove the tread plate.
9. Pull back the trim on the truck door opening.
10. Remove the trim fasteners and pull back the floor mat to reveal the two panel fasteners on the inner kick panel.
11. Remove the two panel fasteners then remove the inner kick panel.
12. Disconnect the door wiring harness from the cab wiring inside the dash.
13. Pull the door wiring harness and connector out through the holes inside the cab and the forward door frame, then push the wiring and connectors into the door through the hole on the forward edge of the door. It may be necessary to remove or loosen vapor barriers. See [Fig. 4](#).

FLA COE
 FLB COE
 FLD Conventional
 Business Class
 FLC 112 Conventional

Century Class Conventional
 > Argosy
 Cargo
 Columbia
 > 122SD and Coronado

Business Class M2
 Cascadia
 108SD/114SD
 New Cascadia

**Freightliner
 Service Bulletin**

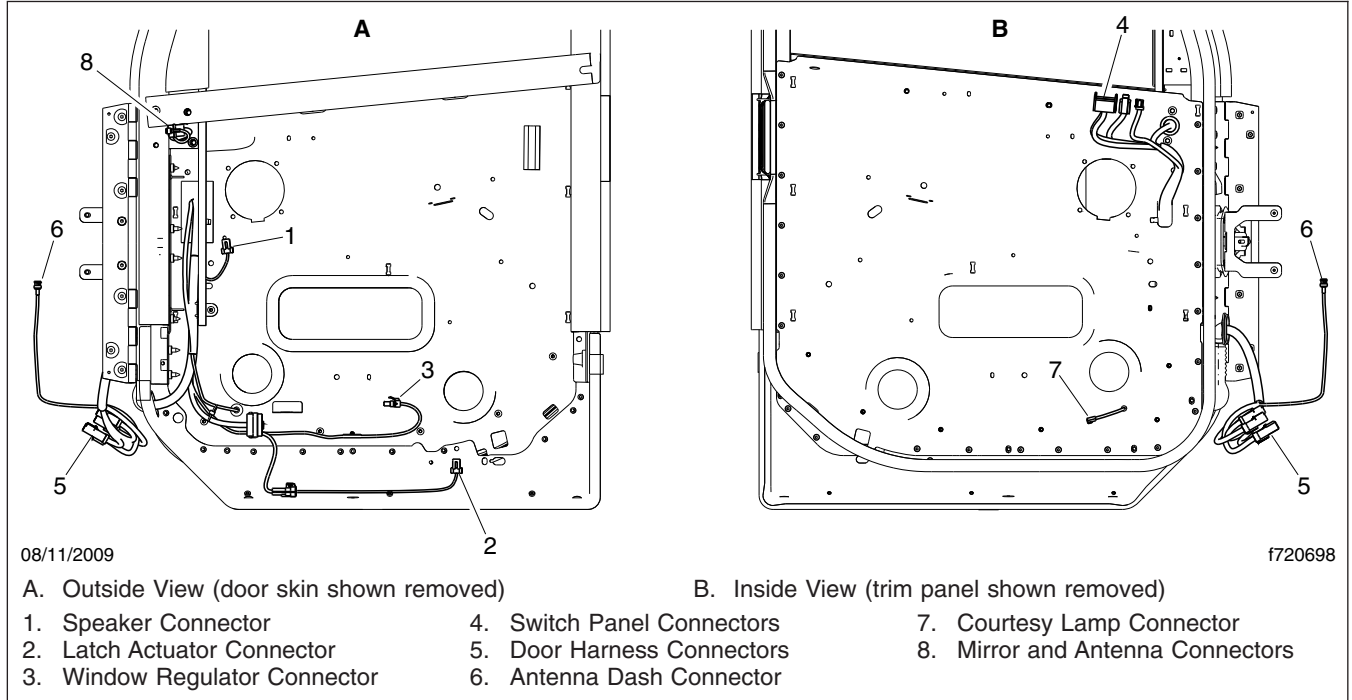

Fig. 4, Door Wiring Harness, LH Door Shown

- Remove the six bolts that attach the window regulator to the inner door panel then cut the two zip tie fir trees to detach the window regulator assembly. See [Fig. 5](#).

Freightliner Service Bulletin

FLA COE
FLB COE
FLD Conventional
Business Class
FLC 112 Conventional

Century Class Conventional
> Argosy
Cargo
Columbia
> 122SD and Coronado

Business Class M2
Cascadia
108SD/114SD
New Cascadia

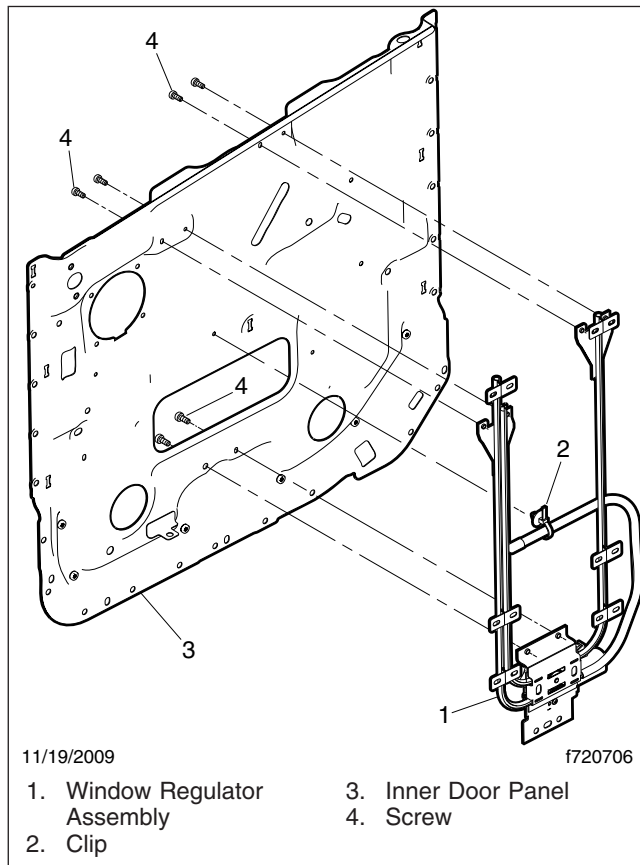

Fig. 5, Old Style Window Regulator Fastener Locations

15. While supporting the inner door panel, remove the remaining screws that attach the inner door panel to the door.
16. Lift off the inner door panel and disconnect the regulator and door lock wiring. Remove the inner door panel.
17. Pull the old glass and regulator up and out of the door.

Regulator Replacement

1. Remove the inner belt scraper seal on the flange at the top of the inner door panel.
2. Mark two new holes and one slot to be drilled for the new regulator on the inner door panel. See [Fig. 6](#), [Fig. 7](#), [Fig. 8](#), [Fig. 9](#), and [Fig. 10](#).

FLA COE
FLB COE
FLD Conventional
Business Class
FLC 112 Conventional

Century Class Conventional
> Argosy
Cargo
Columbia
> 122SD and Coronado

Business Class M2
Cascadia
108SD/114SD
New Cascadia

**Freightliner
Service Bulletin**

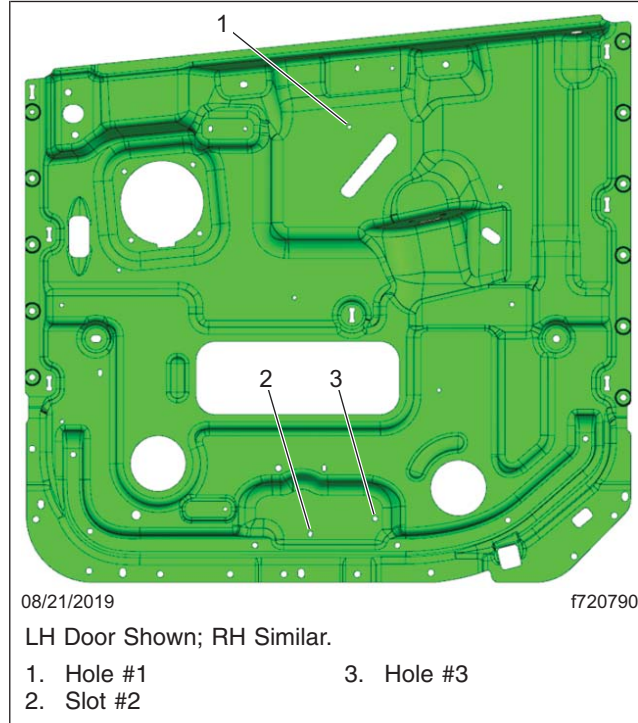

Fig. 6, Overview of New Hole Locations for 24U Door

Freightliner Service Bulletin

FLA COE
FLB COE
FLD Conventional
Business Class
FLC 112 Conventional

Century Class Conventional
> Argosy
Cargo
Columbia
> 122SD and Coronado

Business Class M2
Cascadia
108SD/114SD
New Cascadia

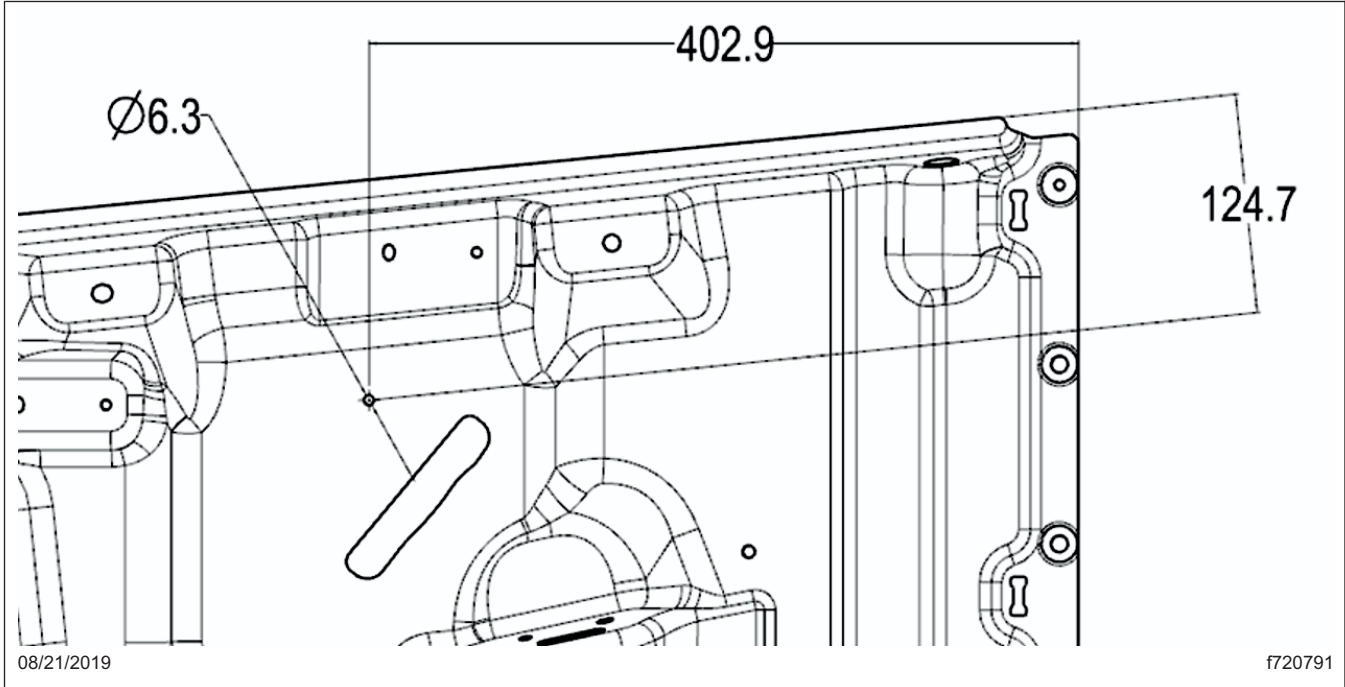

Fig. 7, Measurements in mm for Marking Hole #1

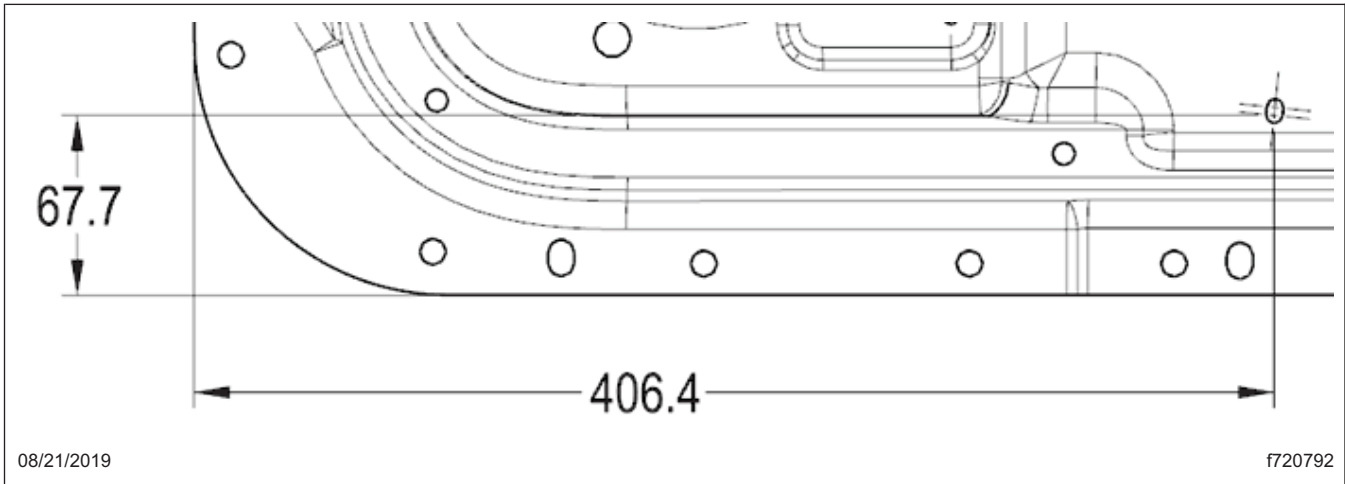

Fig. 8, Measurements in mm for Marking Slot #2

FLA COE
 FLB COE
 FLD Conventional
 Business Class
 FLC 112 Conventional

Century Class Conventional
 > Argosy
 Cargo
 Columbia
 > 122SD and Coronado

Business Class M2
 Cascadia
 108SD/114SD
 New Cascadia

**Freightliner
 Service Bulletin**

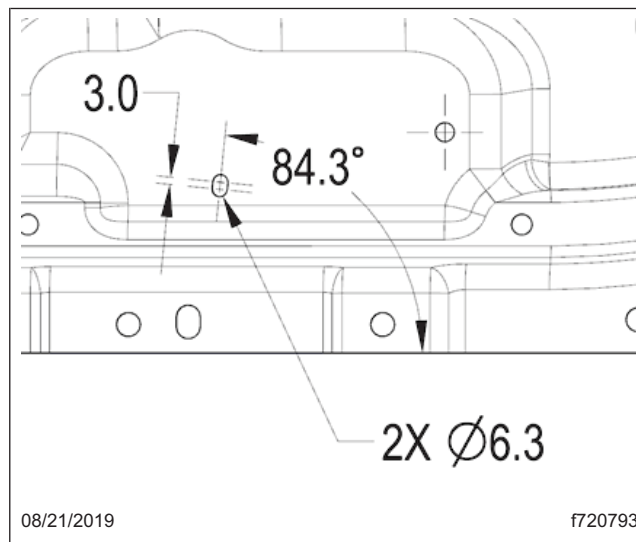

Fig. 9, Detail Measurements in mm for Slot #2

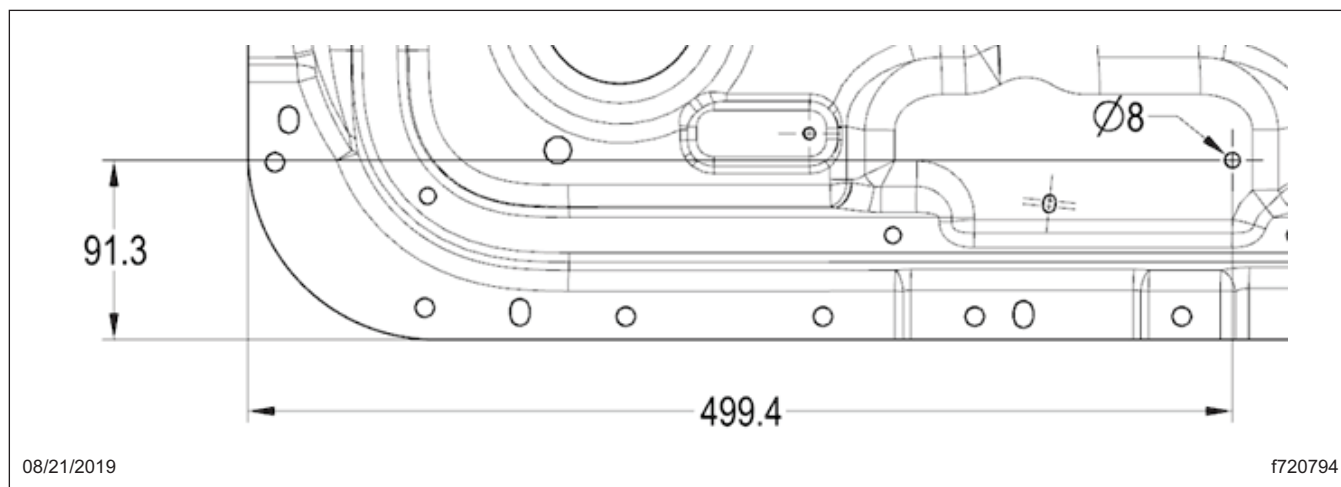

Fig. 10, Measurements in mm for Marking Hole #3

3. Drill the new holes for the new regulator.
4. Check the fit between the new holes on the inner door panel and the new regulator.
5. Clean up the metal from the drilling.
6. Paint the new holes to protect them.
7. Starting at the top, fasten the new regulator to the inner door panel with one nut and two bolts. The new bolts should be the same size as those that were removed.
 - 7.1 Fasten the regulator assembly to the inner door panel with the nut. See [Fig. 11](#).

**Freightliner
Service Bulletin**

FLA COE
FLB COE
FLD Conventional
Business Class
FLC 112 Conventional

Century Class Conventional
> Argosy
Cargo
Columbia
> 122SD and Coronado

Business Class M2
Cascadia
108SD/114SD
New Cascadia



Fig. 11, Nut Fastening Regulator Assembly to Upper Inner Door Panel

- 7.2 Fasten the regulator assembly to the inner door panel with two bolts. See [Fig. 12](#). Torque bolts to 5 ± 1 lbf-ft (7 N·m).

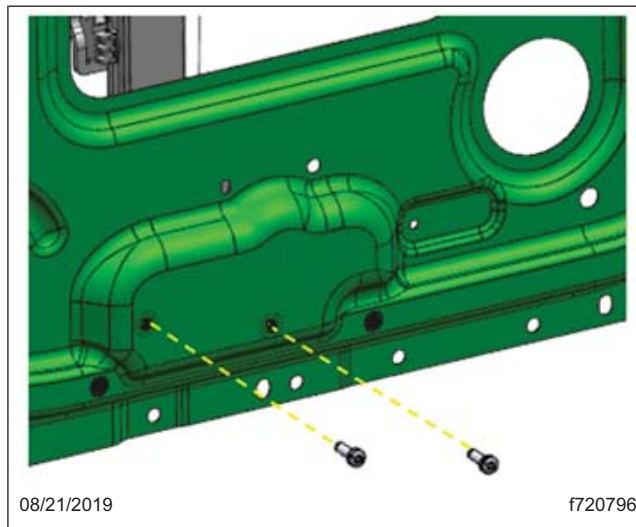

Fig. 12, Screws Fastening Assembly to Lower Inner Door Panel

Inner Door and Window Glass Installation

1. Install the inner belt scraper seal on the flange at the top of the inner door panel.
2. Install the new glass into the upper door frame.
3. Using care not to bend the door lock rod, lower the inner door panel over the door lock rod on the door assembly. Install the rear upper screw loosely, then install the forward upper screw, again loosely, to hold the panel in place. Make sure to connect the harness in the bottom of the door.
4. Connect the lower end of the door lock rod to the exterior door handle mechanism and the door lock actuator and connect the interior handle rod to the door lock actuator. See [Fig. 3](#).

FLA COE
FLB COE
FLD Conventional
Business Class
FLC 112 Conventional

Century Class Conventional
> Argosy
Cargo
Columbia
> 122SD and Coronado

Business Class M2
Cascadia
108SD/114SD
New Cascadia

**Freightliner
Service Bulletin**

5. Route the door wiring harness through the hole in the forward edge of the door, the door frame, and into the interior of the cab. Connect it to the cab wiring harness connectors. Make sure the rubber grommets are seated in the openings.
6. Snap the glass into the new window regulator.
7. Install the rest of the screws that secure the inner panel to the door. Torque the screws 55 to 70 lbf-in (600 to 800 N·cm).
8. Move the window glass up and down to test it.
9. Route the mirror wiring and antenna cable through the outer door panel and the lower mirror mount then connect them.
10. Install the two screws on the lower mirror mount, securing the mount and the forward edge of the inner door panel to the door. See **Fig. 2**. Torque 10 to 12 ft·lbs (13 to 16 N·m).
11. Install the mirror mount cover.
12. Install any removed or loosened vapor barriers.

Trim Panel Installation

1. Lower the trim panel over the lock knob.
2. Before attaching the panel, pull the door switch wiring connector up through the panel and push the courtesy lamp connector through the hole in the lower portion of the panel.
3. Firmly press on the sides of the trim panel to engage the backside clips in the inner door panel.
4. Connect the door switch panel to the wiring, then push the switch bezel and switch assembly in place so that is snug and flush with the trim panel.
5. Attach the bottom of the trim panel using five screws. Torque to 5±1 lbf·ft (7 N·m)
6. Install the map pocket to the trim panel using the six screws. Torque to 5±1 lbf·ft (7 N·m).
7. Connect the courtesy light to the wiring and clip it in place at the bottom of the map pocket.
8. Install the interior door release handle. Torque the screw 55 to 70 lbf-in (600 to 800 N·cm).
9. Install the door grab handle using the two screws. Torque to 17±1 lbf·ft (23 N·m).
10. Attach the portion of the door seal that was loosened to remove the interior trim panel.
11. Install inner kick panel with the two panel fasteners.
12. Put the floor mat back in place and install the trim fasteners and trim on the truck door opening.
13. Install the tread plate with the three screws.

Warranty

Normal warranty applies. See **Table 3** for OWL VMRS codes and labor allowance information. Enter this service bulletin number in the Service Bulletin # field.

OWL VMRS Codes and Labor Allowance					
Primary Failed Part	Component Code	Cause Code	SRT Code	Description	Time: Hours

**Freightliner
Service Bulletin**

FLA COE
FLB COE
FLD Conventional
Business Class
FLC 112 Conventional

Century Class Conventional
> Argosy
Cargo
Columbia
> 122SD and Coronado

Business Class M2
Cascadia
108SD/114SD
New Cascadia

OWL VMRS Codes and Labor Allowance					
Regulator Assembly - Window, C	002-018-011	03	654-5000A	Regulator and Glass, Cable Style, Retrofit (SB72-043)	1.5

Table 3, OWL VMRS Codes and Labor Allowance