



Countries: UNITED STATES **Document ID:** IK2200145
Availability: ISIS, Bus ISIS, IsSIR **Revision:** 0
Major System: BUS BODY **Created:** 10/14/2019
Current Language: English **Last Modified:** 10/28/2019
Other Languages: NONE **Author:** Brandon Akridge
Viewed: 74

[Less Info](#)

Hide Details

Coding Information

Copy Link 	Copy Relative Link 	Bookmark View My Bookmarks	Add to Favorites 	Print 	Provide Feedback 	Helpful 5	Not Helpful 2
----------------------	-------------------------------	--	-----------------------------	------------------	-----------------------------	-------------------------	-----------------------------

Title: Bus Strobe Light Replacements

Applies To: bus strobe lights 2229568c91 and 2230289c91 (terminated strobe light 6290000)

CHANGE LOG

Please refer to the change log text box below for recent changes to this article:

10/28/2019 - Initial Article Release

DESCRIPTION

This document will guide the user through selecting a replacement strobe light for obsolete bus strobe lights 2229568C91 and 2230289C91 (terminated strobe light 6290000), as well as any installations procedures needed to do this operation.

SYMPTOM(s)

Need to replace an obsolete bus strobe light

SPECIAL TOOL(s) / SOFTWARE

N/A

SERVICE PARTS INFORMATION

Parts listed below are the replacement strobe choices and parts to re-terminate the existing supply harness that connects to the new strobe light.

Kit Description	Part Number	Quantity Required	Notes
LIGHT, STROBE, BUS BODY, DOUBLE FLASH 4.5 INCH LED	4078590C91	1	Replaces 2229568C91
LIGHT, STROBE, LED, WHITE, DOUBLE FLASH 2.77" HIGH	4078589C91	1	Replaces 2230289C91 / 6290000
TERMINAL,CABLE, CABLE FEMALE	1661261C1	2	
LOCK,CONNECTOR BODY, TPA M/P 2	1661263C1	1	
CONNECTOR,BODY, 2 WAY	1661259C1	1	

DIAGNOSTIC STEP(s)

Step	Action	Decision

# 1	<p>DIAGNOSTIC: Are you replacing strobe light 2229568C91?</p>	<p>Yes. Follow Repair Procedure A.</p>
		<p>No. Go to Step #2.</p>

Step	Action	Decision
# 2	<p>DIAGNOSTIC: Are you replacing strobe light 2230289C91 or 6290000?</p>	<p>Yes. Follow Repair Procedure B.</p>
		<p>No. This article does not apply.</p>

REPAIR STEP(s)

REMOVAL PROCEDURE A:



Figure #1: Strobe light 2229568C91

1. Remove the 6 screws around the perimeter of the strobe light, as shown in Figure 1.
2. Lift strobe light and disconnect the harness, the strobe can be discarded.

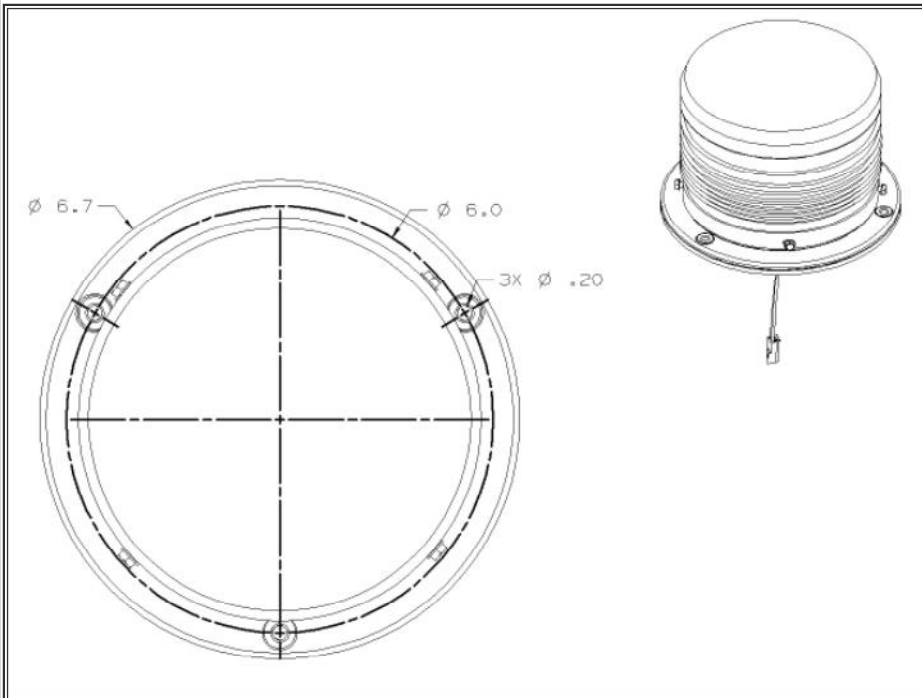
INSTALLATION PROCEDURE A:**Figure #2: 4078590C91**

1. When installing the new strobe with the 3 mounting hole pattern, see figure #2, special attention will need to be placed on the location of the old hole verses where the new holes will go.
2. It is not recommended to try to reuse any of the existing 6 hole pattern
3. Slightly rotate the strobe light on the roof without the rubber seal and mark the orientation before installing.
4. Add a high quality sealant into each of the old mounting holes prior to installing the new strobe assembly
5. Modify existing wire harness with connector/terminals (1661261C1, 1661263C1, 1661259C1)
6. Connect the new strobe light to the modified harness. Do not connect the replacement lamp to the old power supply/flasher.
7. Install the replacement lamp with gasket to the roof, utilizing the previously marked holes.

REMOVAL PROCEDURE B:**Figure #3: 2230289C91**

1. Remove the 4 screws around the perimeter of the strobe light as shown in figure 3.

2. Lift strobe light and disconnect the harness, strobe can be discarded.

INSTALLATION PROCEDURE B:

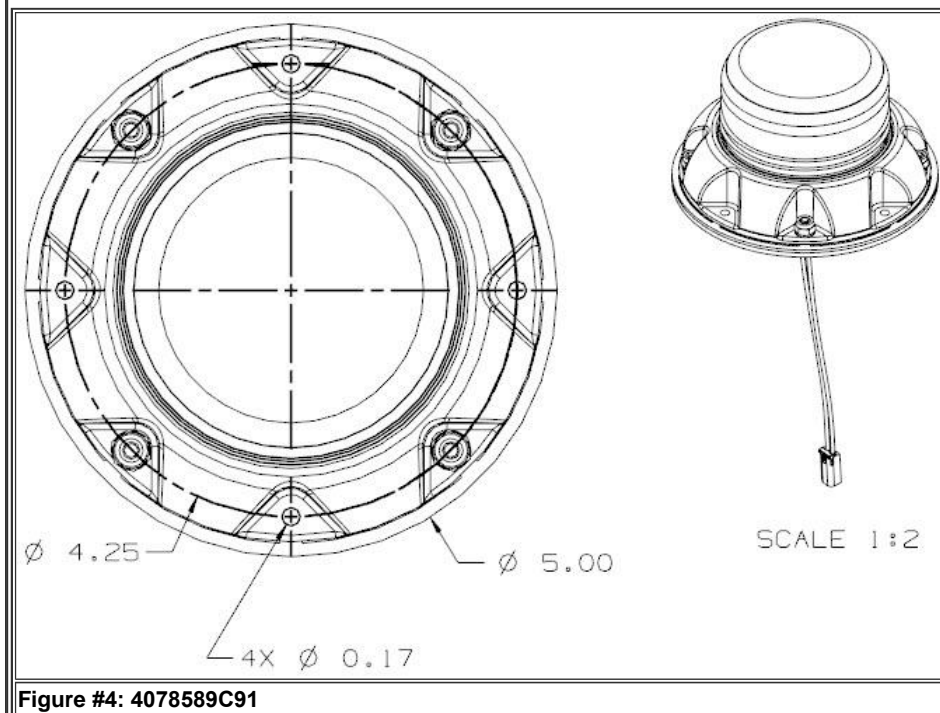

Figure #4: 4078589C91

1. When installing the new strobe with the 4 mounting hole pattern, see figure #4, special attention will need to be placed on the location of the old hole verses where the new holes will go.
2. It is not recommended to try to reuse any of the existing hole pattern
3. Slightly rotate the strobe light on the roof without the rubber seal and mark the orientation before installing.
4. Add a high quality sealant into each of the old mounting holes prior to installing the new strobe assembly
5. Modify existing wire harness with connector/terminals (1661261C1, 1661263C1, 1661259C1)
6. Connect the new strobe light to the modified harness. Do not connect the replacement lamp to the old power supply/flasher.
7. Install the replacement lamp with gasket to the roof, utilizing the previously marked holes.

WARRANTY INFORMATION

Warranty Claim Coding:

Refer to the [Warranty Coding Manual](#) for Group and Noun Codes.

GA65-1550A is the SRT for replacing a Strobe Light.

Standard Repair Time(s):

Refer to the [SRT Manual](#) for Repair Times

OTHER RESOURCES

[Master Service Information Site](#)

Staff ID	Client ID	Comments	Created Date
	DYYDAL8	You received the following feedback From: dyydal8 - DeWayne Lutes Email Address: dewaynelutes@wiers.com Job Classification: PA003, Parts Counter Person Dealer: WIERS INT'L TRUCKS, INC Feedback: a valid part number would be useful (4078589c91 is not)	10/30/2019 11:06:45 AM



Copyright © 2019 Navistar, Inc.