

Trailer Hitch (I-no. 1D6 or 1D3/1D9)

Revision: This bulletin replaces bulletin Group 6, #29/18, dated December 13, 2018. This revision includes:

- Addition of Cayenne Coupe models
- Additional information notes added
- Additional work procedure steps were added

Model Year: **As of 2018**

Concern: **Retrofitting**

Note: The new Cayenne can be retrofitted with a trailer hitch (). Note the following special features:

- Permissible hook load of 309 lbs (140 kg)
- Totally versatile wading depth
- Convenient loading and safe parking is assured by removing the ball hitch/bar (mechanical trailer hitch – 1D6)
- Socket preparation for USA version
- Payload following installation, restricted by higher vehicle curb weight!
- Gross vehicle weight and axle load must not be exceeded!

The trailer hitch can also be ordered as an option from the factory by requesting optional equipment "1D6" = mechanical trailer hitch.

Important: The electric extending and retracting hitch at the touch of a button (electric trailer hitch) is not available for the USA. Some references/work procedure steps pertain to "electric hitch" are not applicable. THE "mechanical trailer hitch" is applicable for USA (See Figure 1, item 2).

Parts Info: **9Y0.044.840.01** ⇒ Trailer hitch, mechanical – USA (1D6)

ONLY for vehicles with Comfort Access (4F2/4F6 – Powerlift tailgate with virtual pedal): Also order the following:

WHT.005.450 8 x ⇒ Tie-wrap

ONLY for vehicles with SportDesign package Carbon (2D3): Also order the following, depending on country/market:

9Y0.807.834.H.03G 1 x ⇒ Rear panel - open, shiny carbon, black – USA

Parts List:

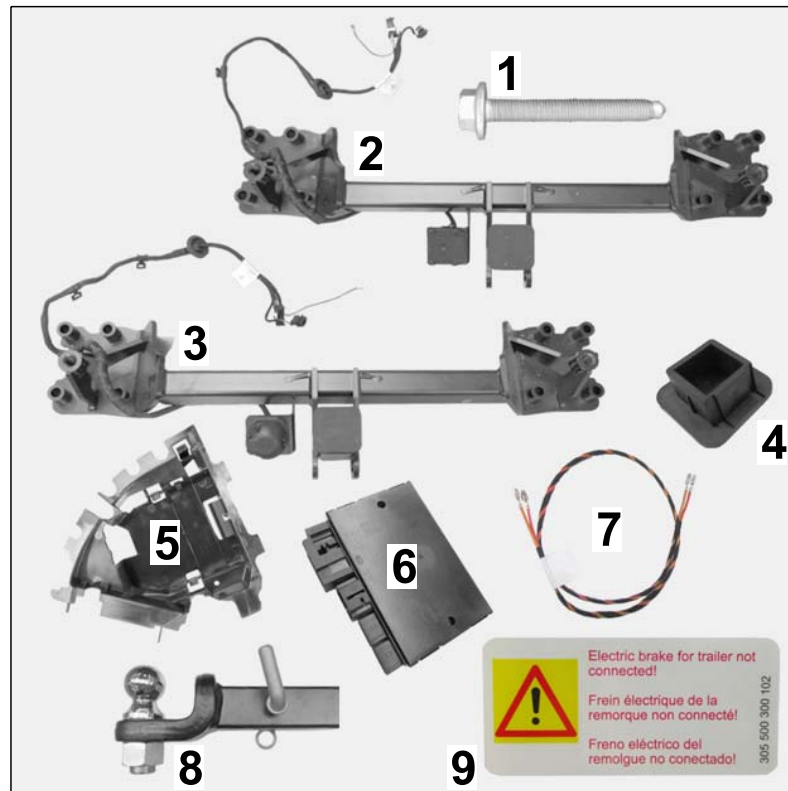

Figure 3

Parts included with trailer hitch – mechanical – USA/Canada (1D6 ⇒ Figure 3):

PAF.910.398.02	8 x	Hexagon-head bolt, M12 x 1.5 x 90 ⇒ Figure 3-1-
9Y0.803.881.A	1 x	Trailer hitch incl. wire harness – USA/Canada (1D6) ⇒ Figure 3-2-
9Y0.803.881.B	1 x	Not for USA ⇒ Figure 3-3-
955.722.030.00 ¹	1 x	Stopper for trailer hitch ⇒ Figure 3-4-
9Y0.907.297	1 x	Trailer hitch control unit bracket ⇒ Figure 3-5-
9A7.907.383.01	1 x	Trailer hitch control unit ⇒ Figure 3-6-
— — —	1 x	Wiring harness for power supply (terminal 30) ⇒ Figure 3-7-
955.044.000.28	1 x	Ball hitch –removable– USA/Canada ⇒ Figure 3-8-
— — —	1 x	"Electric Brake" sticker – identification ⇒ Figure 3-9-
— — —	10 x	Tie-wrap, 150 mm (not shown)

¹ Already fitted on the trailer hitch!

Tools:

Nr.88 supersedes to VAS 6942 or equivalent	VAS 6933 (aka. Snap-on A177A) or equivalent
9900 - PIWIS Tester III	Steel drill bit, Ø up to 8.0 mm
Saw or vibrating knife	Drill
Tap, M12 x 1.5	Round/flat file
Side cutters	Flat scraper
Plastic wedge	Shop light
Knife	

Work Procedure: 1 Preparatory work

- 1.1 Connect battery charger (⇒ *Workshop Manual '2X00IN Trickle charging 12-volt lithium-ion battery*).
- 1.2 Raise the vehicle (⇒ *Workshop Manual '4X00IN Lifting the vehicle*)
- 1.3 Remove rear bumper (⇒ *Workshop Manual '635019 Removing and installing rear bumper*)

- 1.4 Expose connector B (6-pin)/connector C (10-pin) on trailer hitch preparation near the fuse box in the luggage compartment (⇒ *Figure 4*).

- 1 – Connector B (6-pin)/connector C (10-pin)
- 2 – Ground pin MB25
- 3 – Fuse box in luggage compartment, left

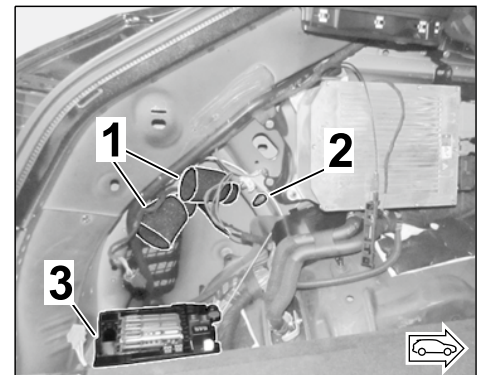

Figure 4

- Carefully remove foam.
- 1.5 **ONLY** for –mechanical– trailer hitch (1D6):
Expose connection point (connector, 2-pin) for brake booster preparation in the luggage compartment area at the left.
 - 1.6 Check that the bolt threads and contact surfaces for securing the trailer hitch are not dirty. Clean them and re-cut the threads using an M12 x 1.5 tap if necessary.

NOTICE

Incorrect line routing

- Risk of damage to lines and hoses
 - Malfunction and fault memory entry on control unit
- ⇒ Avoid small bending radii when routing lines.
- ⇒ File down edges and burrs in the routing area or mask them with adhesive tape.
- ⇒ Maintain a sufficient distance from components exposed to high temperatures while driving.

- 1.7 **ONLY** for vehicles with Comfort Access (4F2/4F6) – Powerlift tailgate with virtual pedal:
Convert "Virtual pedal" antenna line in the rear apron

- 1 – "Virtual pedal" antenna line
- 2 – Control unit for "Virtual pedal" antenna line
- 3 – Positions of tie-wraps on adhesive pads
- 4 – Tie-wrap with adhesive pad
- 5 – New line routing for "Virtual pedal" antenna line

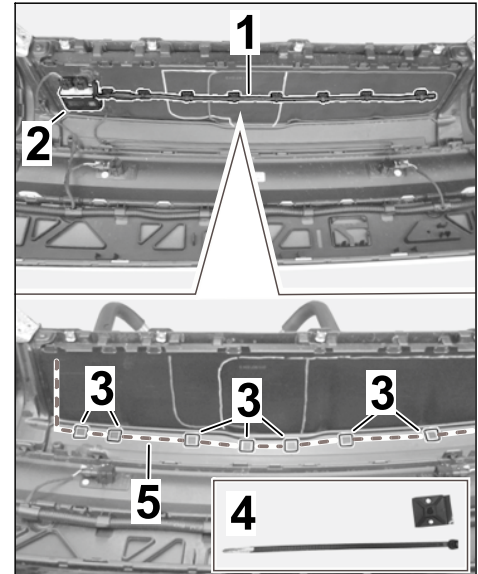

Figure 5

- 1.7.1 Carefully remove "Virtual pedal" antenna line with holder and tie-wraps (7 x) from the inside of the rear apron (⇒ *Figure 5-1-*).
- 1.7.2 Carefully cut open tie-wraps on adhesive pads and remove tie-wraps (7 x) from antenna line.
- 1.7.3 Clean bonding area in the new antenna line routing area to remove any dust and grease (⇒ *Figure 5-3-*).
- 1.7.4 Stick on new adhesive pads (7 x) with tie-wraps at the markings.
- 1.7.5 Secure "Virtual pedal" antenna line in new tie-wraps (7 x) and cut off excess length of tie-wraps.
- 1.8 **ONLY** for vehicles **WITH** SportDesign package Carbon (2D3):
Replace rear panel – closed (shiny carbon, black) with new rear panel – open (shiny carbon, black) (⇒ *Workshop Manual '63561940 Removing and installing rear panel (moulding)*)



Information

Mask the sawing area to prevent damage.

- 1.9 **ONLY** for vehicles **WITHOUT** SportDesign package Carbon (2D3):
Make a cut-out for the (removable/pivoting) ball hitch in the rear apron.
- 1.9.1 Remove rear panel (moulding) in black matt (2JB) or stainless steel (2JX) on the bottom of the rear apron (⇒ *Workshop Manual '63561940 Removing and installing rear panel (moulding)*).

1.9.2 Mark the cut-out for the ball hitch at the impression on the inside of the rear apron (⇒ *Figure 6 -top-*).

- 1 – Red = Marking for cut-out for removable ball hitch
- 2 – Yellow = Marking for cut-out for electrically extendable ball hitch
- 3 – Not applicable for USA

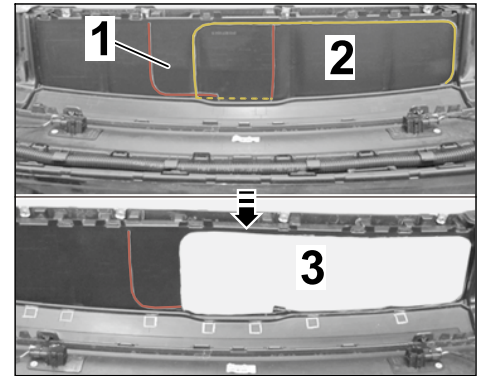

Figure 6

1.9.3 Carefully make the cut-out at the marking (⇒ *Figure 6 -bottom-*).

1.9.4 De-burr cut edges with a knife or file.

1.9.5 Install rear panel (moulding) in black matt (2JB) or stainless steel (2JX) on the bottom of the rear apron (⇒ *Workshop Manual '63561940 Removing and installing rear panel (moulding)*).

2 Install trailer hitch

2.1 Secure trailer hitch to the vehicle

2.1.1 Fit the trailer hitch using 8 new bolts (M12 x 1.5 x 90) at the left and right and tighten hand-tight.

- 1 – Trailer hitch (electric)
- 2 – Screw, M12 x 1.5 x 90

2.1.2 Align bolt guides for the trailer hitch (8 x) symmetrically with respect to the 8 bolt heads (M12 x 1.5 x 90) (⇒ *Figure 7 -inset-*).

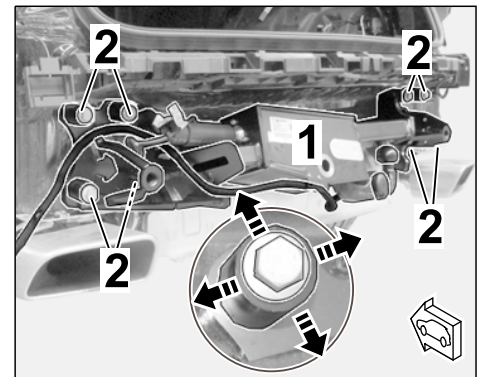

Figure 7

2.1.3 Tighten trailer hitch fully.
tightening torque 110 Nm

2.2 Route electric wire harness for trailer hitch in the passenger compartment (see also ⇒ *Workshop Manual '972419 Removing and installing wire harness for trailer hitch*)

2.2.1 Remove dummy plug (Ø 40 mm) from side panel on the vehicle at the left and guide wire harness for trailer hitch into the luggage compartment.

- 1 – Wire harness for trailer hitch
- 2 – Rubber sleeve (wire harness)
- 3 – Tie-wrap

2.2.2 Insert rubber sleeve (wire harness) into the bore (Ø 40 mm) on the body.

2.2.3 Fit tie-wraps for wire harness (2 x) on threaded bolts on the outside of the vehicle (⇒ *Figure 8*).

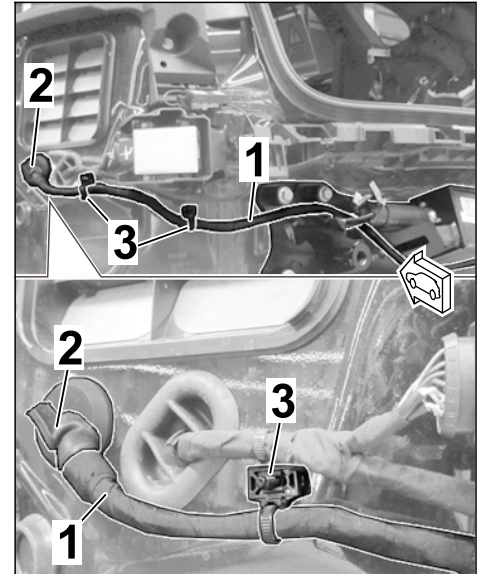

Figure 8

2.3 Check pin assignment in connector B on the vehicle side (6-pin; trailer hitch preparation ⇒ *Figure 9*).

- 1 – Connector B (6-pin; trailer hitch preparation)
- 2 – Connector B, chamber 1
- 3 – Connector B, chamber 6
- 4 – Fuse holder H (strip B – white)

Are chambers 1 (swivel motor) and 6 (charge line) - both on terminal 30 - used?

- Yes: Continue with Step 2.4
- No: Carry out the following work.

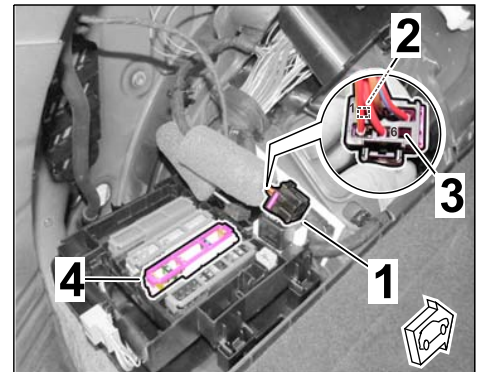

Figure 9

2.3.1 Remove fuse holder H (strip B – white) from the fuse box in the luggage compartment (⇒ *Workshop Manual '978409 Loosening and securing fuse box in the luggage compartment'* ⇒ *Figure 10-top-*).

- 1 – Fuse holder H (strip B – white)
- 2 – Cover on underside
- 3 – Latch on fuse holder
- 4 – RD/GN line 2.5²

2.3.2 Release fuse holder H (strip B – white) and connect the lines (RD/GN and RD/YE) as follows (⇒ *Figure 10-bottom-*):

- Chamber 6: RD/GN line 2.5² ⇒ Preparation for connector B, chamber 1 (swivel motor)
- Chamber 7: RD/YE line 2.5² ⇒ Preparation for connector B, chamber 6 (charge line)

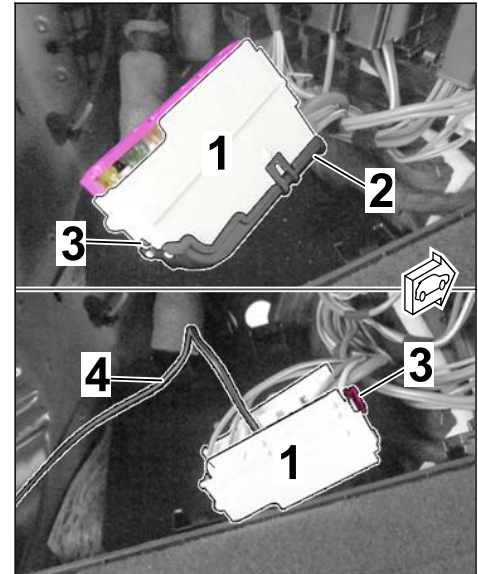

Figure 10

2.3.3 Lock connector housing strip B (color: white) and fit it into the fuse holder.

2.3.4 Fit fuse holder H (strip B – white) in the fuse box in the luggage compartment (⇒ *Workshop Manual '978409 Loosening and securing fuse box in the luggage compartment'*).

2.3.5 Route RD/GN and RD/YE lines to connector B (preparation). (⇒ *Figure 11*).

- 1 – RD/GN and RD/YE lines
- 2 – Connector B (preparation)
- 3 – Fuse box in luggage compartment

Release connector B, connect lines RD/GN and RD/YE as described in Step 2.3.2 (⇒ *Figure 11-inset-*).

Lock connector B.

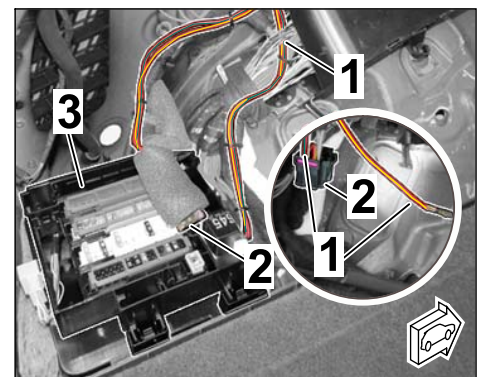

Figure 11

2.4 Install trailer hitch control unit in the luggage compartment area (left side panel)

- 1 – Trailer hitch control unit bracket
- 2 – Connector A – wire harness for trailer hitch
- 3 – Ground line 2.5² – BN
- 4 – Ground pin MB25

2.4.1 Disconnect any lines and hoses in the installation area.

2.4.2 Insert pins (2 x on underside of control unit bracket) into the body (⇒ *Figure 12-A-*)

2.4.3 Clip trailer hitch control unit bracket at the top into the web plate on the body (⇒ *Figure 12-B-*).

2.4.4 Guide connector A (wire harness for trailer hitch) and connector B/C (trailer hitch preparation) into the control unit bracket.

2.4.5 Fit trailer hitch control unit into the bracket (⇒ *Figure 13*).

- 1 – Trailer hitch control unit
- 2 – Bracket

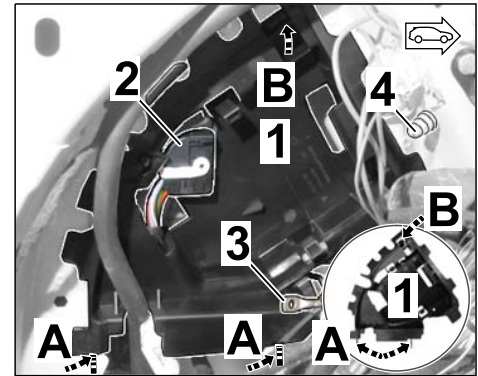

Figure 12

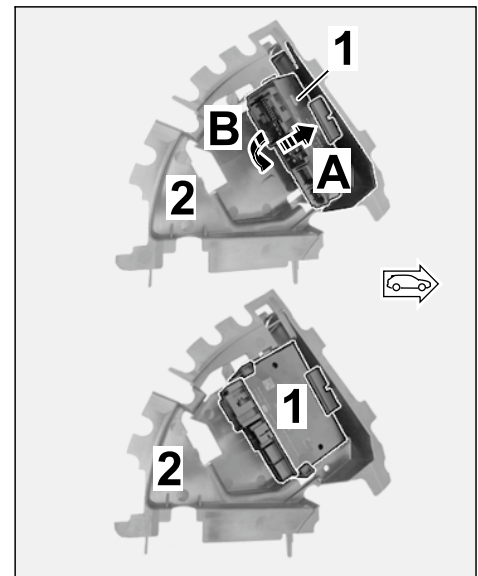

Figure 13

2.5 Fit cable ring eyelet A6 at the ground pin MB25 (⇒ *Figure 14-2-*).

- 1 – Ground line BN 2.5²
- 2 – Ground pin MB25
- 3 – Connector A (wire harness for trailer hitch)
- 4 – Connector B (preparation)
- 5 – Connector C (preparation)
- 6 – Trailer hitch control unit

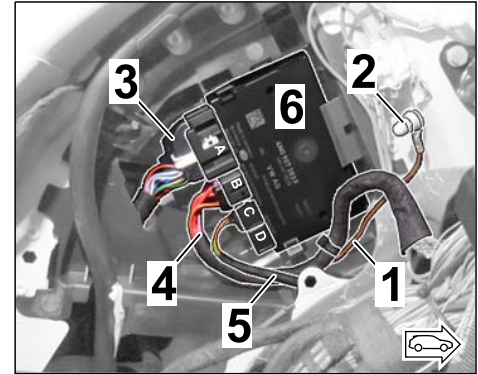

Figure 14

2.6 Connect plug connections for connector A/B/C to the trailer hitch control unit (⇒ *Figure 14*).

2.7 **ONLY** for –mechanical– trailer hitch (1D6):

2.7.1 Connect plug connection (2-pin ⇒ *Figure 15*) for brake booster preparation in the luggage compartment area at the left.

- 1 – Connector (2-pin) – brake booster preparation
- 2 – Connector A
- 3 – Ground line BN 2.5²

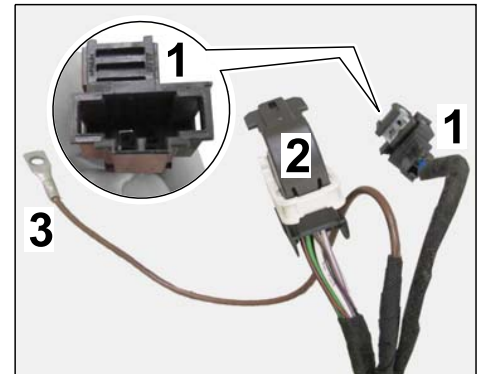

Figure 15

Fit connection point at a suitable location using a clip.

2.7.2 Affix sticker showing the warning "Electric Brake for Trailer not connected" on a clean surface at a clearly visible position next to the "Ball Position" sticker or the dashboard (⇒ *Figure 16*).

- 1 – "Electric Brake for Trailer not connected" warning sticker
- 2 – "Ball Position" sticker

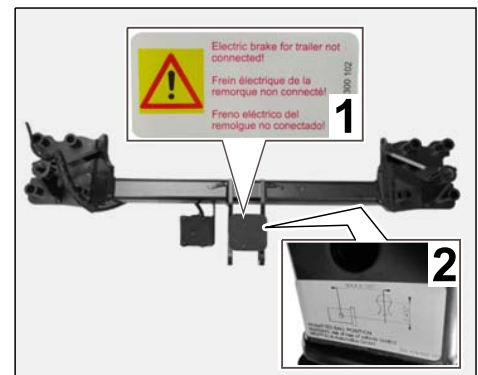

Figure 16

2.8 Check fuse assignment in fuse holder H (strip B – white ⇒ *Figure 17*) and insert missing fuses if necessary:

- Fuse slot 5 = trailer hitch (right light) = 25 A
- Fuse slot 6 = trailer hitch (swivel motor) = 30 A
- Fuse slot 7 = trailer hitch (attaching trailer & electric release) = 15 A
- Fuse slot 9 = trailer hitch (plug socket) = 15 A



Figure 17

NOTICE

Incorrect line routing

- Risk of damage to lines and hoses
 - Malfunction and fault memory entry on control unit
- ⇒ Avoid small bending radii when routing lines.
- ⇒ File down edges and burrs in the routing area or mask them with adhesive tape.
- ⇒ Maintain a sufficient distance from components exposed to high temperatures while driving.

3 **ONLY** for –electric– trailer hitch (1D3/1D9):
Route and connect electric wire harness (⇒ *Figure 18*) for trailer hitch switch.

- 1 – Connector D (10-pin) – trailer hitch control unit
- 2 – Connector (2-pin) – bridge for "light" on trailer hitch switch
- 3 – Connector (12-pin) – trailer hitch switch

3.1 Remove side trim panel for luggage compartment (at the right) ⇒ *Workshop Manual '700319 Removing and installing side trim panel for rear luggage compartment'*.

3.2 **ONLY** for vehicles with standard springs/chassis (1BA/1BH):
Create bridge for "light" on switch for –electric– trailer hitch (1D3)

- 3.2.1 Remove luggage rail, support at the left and rear-end electronics control unit with holder from the luggage compartment (⇒ *Workshop Manual '578919 Removing and installing rear-end electronics'*).

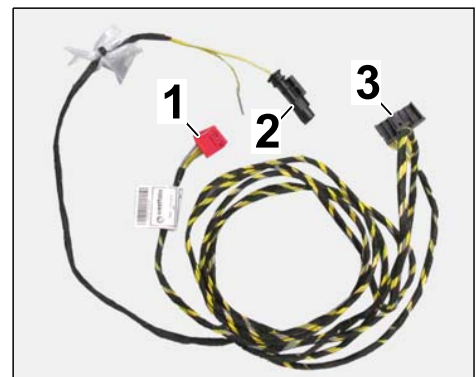

Figure 18

3.2.2 Release connector housing (2-pin ⇒ *Figure 19-1-*, secured to wire harness for trailer hitch switch in a bag).

- 1 – Plug connection (2-pin) – wire harness for switch
- 2 – Connector A (17-pin, green)
- 3 – CY/BU line 0.35²
- 4 – YE/BK line – wire harness for switch
- 5 – Rear-end electronics control unit

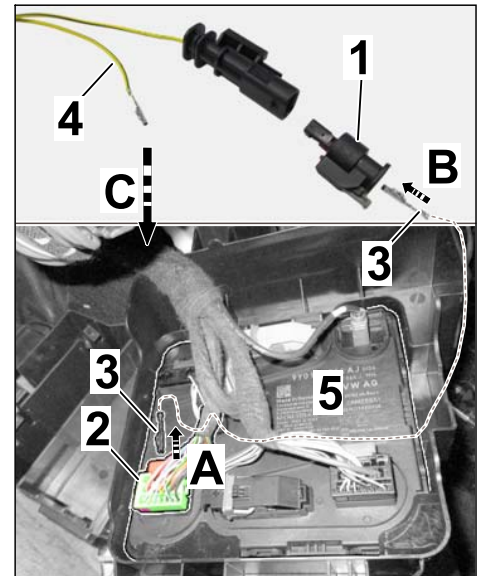

Figure 19

3.2.3 Remove connector A (17-pin, green ⇒ *Figure 19-2-*) from rear-end electronics control unit and release it.

3.2.4 Unpin CY/BU line 0.35² from chamber 5 (connector A, 17-pin, green) (⇒ *Figure 19-A-*).

Then insert it into chamber 1 (connector housing, 2-pin, wire harness for switch) (⇒ *Figure 19-B-*).

3.2.5 Check that the same chambers in the connector housing/plug socket (2-pin) are used.

Lock connector housing (2-pin) and connect plug connection.

3.2.6 Insert YE/BK line (wire harness for switch) into chamber 5 (connector A, 17-pin, green) (⇒ *Figure 19-C-*).

Lock connector housing and fit it into the rear-end electronics control unit.

3.2.7 Route wire harness for switch with connector D (10-pin) to the trailer hitch control unit.

Secure wire harness in the passenger compartment to existing lines/components with tie-wraps without tensile stress and so that no chafing occurs.

3.2.8 Install rear-end electronics control unit in the luggage compartment (⇒ *Workshop Manual '578919 Removing and installing rear-end electronics'*).

Tightening torque 3 Nm (2 ftlb.)

3.3 **ONLY** for vehicles with Surround Sound System (9VJ/9VL):

Remove subwoofer (⇒ *Workshop Manual '913619 Removing and installing subwoofer (Burmester)'* or ⇒ *Workshop Manual '913619 Removing and installing subwoofer (Bose)'*).

3.4 Route electric wire harness for switch for –electric– trailer hitch (1D3).

- 3.4.1 Insert connector D (10-pin) in slot D on the trailer hitch control unit (⇒ *Figure 20*).

- 1 – Connector D (10-pin)
- 2 – Trailer hitch control unit
- 3 – Insulating tape
- 4 – Tie-wrap

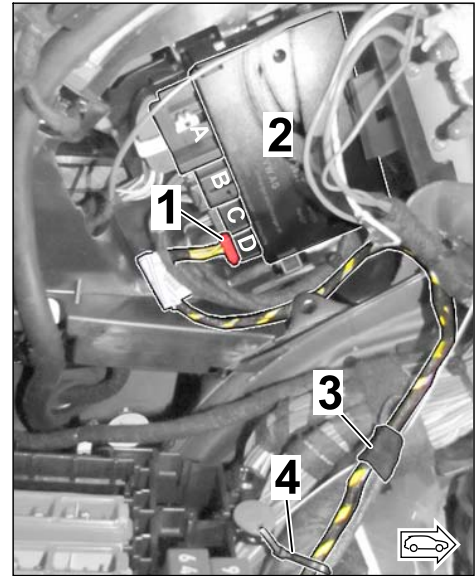

Figure 20

- 3.4.2 Route wire harness for switch along the existing wire harnesses as follows to the right side of the luggage compartment (⇒ *Figure 27*):

- 1 – Wire harness for switch
- 2 – Luggage rail (left)
- 3 – Tie-wrap

Trailer hitch control unit → under luggage rail (left) → rear closing panel → under luggage rail (right) → side panel (right)

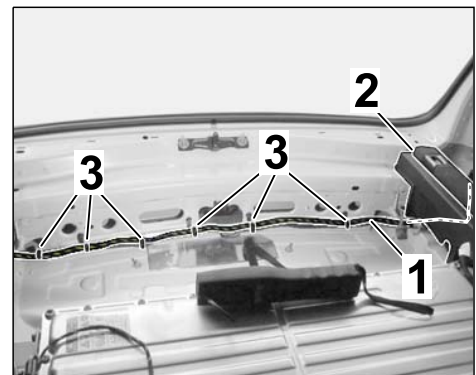

Figure 21

- 3.4.3 Secure electric wire harness in the passenger compartment to existing lines/components with tie-wraps without tensile stress and so that no chafing occurs.

3.5 **ONLY** for vehicles with air suspension with levelling system and vertical adjustment (1BK): Adapt new connector housing (12-pin, electric wire harness for trailer hitch) for new switch for trailer hitch/rear lowering.

3.5.1 Release connector (12-pin) on vehicle side for switch for rear lowering (1BK) (see also ⇒ *Figure 22*).

3.5.2 Release new connector (12-pin, switch for trailer hitch – 1D3/1D9 and rear lowering (1BK) (⇒ *Figure 22*).

Unpin BK/YE line from chamber 6 (light on switch) and secure it.

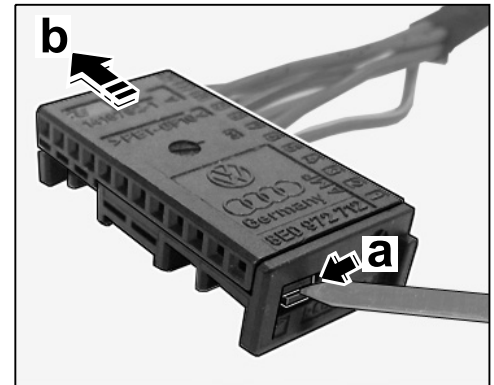

Figure 22

3.5.3 Unpin lines on the connector (12-pin) on vehicle side from chambers 1–6 and pin them at the same position in the new connector (12-pin) (⇒ *Figure 23 -B-*).

- A** – Connector (12-pin) – switch for rear lowering
- B** – Connector (12-pin) – switch for trailer hitch/rear lowering
- 1** – YE/CY – Up
- 2** – WH/VT - redundant level
- 3** – GN/BK – Down
- 4** – BU/CY – function test on level LED
- 5** – BN/YE – ground
- 6** – CY/BU – light on switch

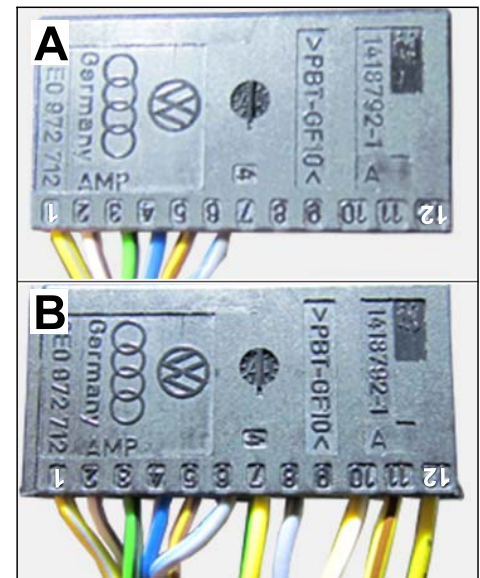

Figure 23

3.5.4 Lock new connector (12-pin).

3.6 **ONLY** for vehicles with standard springs/chassis (1BA): Make cut-out for trailer hitch switch in side trim panel (right).

3.6.1 Mark dimensions for cut-out (trim on trailer hitch switch) on the inside of the side trim panel (right).

- 1 – Side trim panel (right)
- 2 – Cut-out
- 3 – Trailer hitch switch trim



Information

Mask the sawing area to prevent damage.

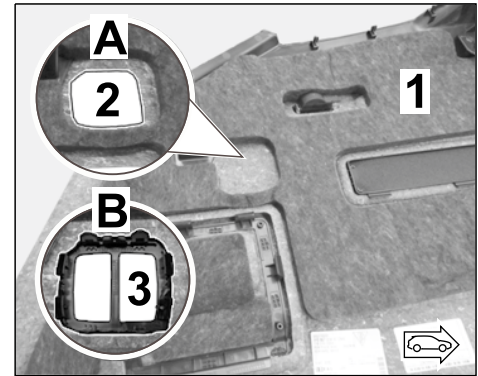

Figure 24

3.6.2 Carefully make a cut-out at the marking (⇒ Figure 24 -A-).

3.6.3 Smooth off cut edges with scissors or a knife.

3.6.4 Clip trim for switch into side trim panel (note installation position of –side guide– ⇒ Figure 24 -B-).

3.7 **ONLY** for vehicles with Surround Sound System (9VJ/9VL):

Install subwoofer (⇒ *Workshop Manual '913619 Removing and installing subwoofer (Burmester)'* or ⇒ *Workshop Manual '913619 Removing and installing subwoofer (Bose)'*).

3.8 Install side trim panel for luggage compartment (at the right) ⇒ *Workshop Manual '700319 Removing and installing side trim panel for rear luggage compartment'*.

3.9 Connect plug connection for switch for trailer hitch or switch for trailer hitch/rear lowering. Install switch in side trim panel for luggage compartment (at the right).

4 Concluding work

4.1 Install side trim panel for luggage compartment ⇒ *Workshop Manual '700319 Removing and installing side trim panel for rear luggage compartment'*.

4.2 Install rear apron (⇒ *Workshop Manual '635519 Removing and installing rear apron'*)

4.3 Lower the vehicle (⇒ *Workshop Manual '4X00IN Lifting the vehicle'*)

Coding:

NOTICE

Voltage drop

- Risk of irreparable damage to control unit
- Risk of damage to control unit
- Fault entries in the control unit
- Coding in the control unit is aborted

- Malfunctions in control unit, even during programming
- ⇒ Switch off the ignition and remove the ignition key before disconnecting the control unit.
- ⇒ Ensure that the power supply is not interrupted during programming.
- ⇒ Connect a battery charger with a current rating of at least Nominal value 90 A to the vehicle battery.

5 Coding/programming trailer hitch (1D6 or 1D3/1D9)

5.1 Preparatory work – Coding

NOTICE

Control unit programming will be aborted if the Internet connection is unstable.

- An unstable Internet connection can interrupt communication between PIWIS Tester III and the vehicle communication module (VCI). As a result, control unit programming may be aborted.
- ⇒ During control unit programming, always connect PIWIS Tester III to the vehicle communication module (VCI) via the USB cable.

5.1.1 **9900 - PIWIS Tester 3** must be connected to the vehicle and switched on.

5.1.2 Switch on ignition **AND** hazard warning lights on the vehicle.



Information

The **9900 - PIWIS Tester III** instructions take precedence since the description may be different with later Tester releases.

The procedure described here has been structured in general terms; different text or additions may appear on the **9900 - PIWIS Tester III**.

5.1.3 Select the "Diagnostics" menu item on the PIWIS Tester.

5.1.4 If **9900 - PIWIS Tester 3** is connected correctly, a connection to the vehicle will be established: "Cayenne" model line is detected.

5.1.5 Press **•F12** to go to the control unit search screen.

5.1.6 Confirm the question: "Create vehicle analysis log (VAL)?" with "Yes" = **•F12** .



Information

The function is **ONLY** available when the Tester is online!

5.2 Enter the new vehicle equipment in the vehicle data using "PIWIS Online"

5.2.1 Press **•F7** in the control unit overview to switch to the "Additional menu".

5.2.2 Select the function "Maintenance of vehicle data with PIWIS ONLINE".

A message appears informing you that the "Actual" (vehicle) data and "Required" (PIWIS Online) data will be compared.

Press **•F12** to continue.

- 5.2.3 Confirm the message "The vehicle data was compared with PIWIS Online. Significant differences were found" with •F12" .
- 5.2.4 Look for the option "TRAILER HITCH" in the "Family" column.
Select "1D6 – TRAILER HITCH WITHOUT TOW BALL (USA)" or "1D9 – EL. RETRACTABLE TRAILER HITCH (E3)", depending on the installed option, from the drop-down menu in the "Value" column. Press •F12" to continue.
- 5.2.5 A table containing the coding value and the columns "new value" and "old value" is displayed in the overview. Press •F8" to continue.
- 5.2.6 Data is then written/stored. The following messages appear one after the other:
- Transferring vehicle data to PIWIS Online.
 - Writing and transferring vehicle data to the vehicle.
 - Vehicle order was written successfully.
 - A check was performed in order to check whether control units have to be coded or programmed as a result of the changes that were made.
- 5.3 Code/program the new vehicle equipment.
- 5.3.1 Confirm the table containing a list of control units that must be coded/programmed by pressing •F12" .
- 5.3.2 Individual data records will be loaded, depending on the number of control units to be coded/programmed.
Wait until the message "Creating backup documentation. Please wait..." and "Coding was completed successfully" appears. Press •F12" to continue.
Repeat the process for other control units if necessary.
- 5.3.3 Wait until the message "Adaptation of the control units is complete." appears and check the coding status of the control units in the table that is displayed.
Continue by pressing •F12" to return to the control unit overview.
- 5.4 **ONLY** for –electric– trailer hitch (1D3/1D9):
Initialise trailer hitch control unit and perform function test
- 5.4.1 Select "Trailer hitch" in the control unit overview and switch to the "Drive links/checks" menu.
- 5.4.2 Select "Mechanics" and then "Trailer hitch calibration". Press •F12" to continue.
- 5.4.3 After the warning message appears, press •F12" to continue.
- 5.4.4 Start the routine with •F8" .
The ball hitch of the electric trailer hitch is fully extended and retracted again.
- 5.4.5 Once the successful "Routine status" is displayed, press •F11" to return to the control unit overview again.
- 5.4.6 Carry out function test(s) on the "trailer hitch" switch and "rear lowering" switch if necessary.

- 5.5 **ONLY** for vehicles with Lane Change Assist (7Y1/7Y2/7Y3 or 7Y8):
Calibrate control unit for Lane Change Assist (⇒ *Workshop Manual '917025 Calibrating Lane Change Assist'*)
- 5.6 Read out the fault memories of all systems, work through any existing faults and erase the fault memories. ⇒ *Workshop Manual '0335IN Diagnostic maintenance: diagnostic system and maintenance inter...'*
- 5.7 Create another vehicle analysis log (VAL) in the "Control unit overview" menu item.
- 5.8 Switch off ignition and disconnect **9900 - PIWIS Tester 3**.
- 5.9 Drive the vehicle off the lifting platform.

66 90 23 00:	-Retrofitting –mechanical– trailer hitch– Includes: Removing and installing rear apron and left side trim panel for rear luggage compartment; Removing rear bumper and installing trailer hitch; Making cut-out for removable ball hitch in rear apron; Coding/programming new vehicle equipment.	Labor time: 238 TU
91 70 25 53:	Programming Lane Change Assist control unit Includes: Calibrating calibration plate on the vehicle.	Labor time: 47 TU

Important Notice: Technical Bulletins issued by Porsche Cars North America, Inc. are intended only for use by professional automotive technicians who have attended Porsche service training courses. They are written to inform those technicians of conditions that may occur on some Porsche vehicles, or to provide information that could assist in the proper servicing of a vehicle. Porsche special tools may be necessary in order to perform certain operations identified in these bulletins. Use of tools and procedures other than those Porsche recommends in these bulletins may be detrimental to the safe operation of your vehicle, and may endanger the people working on it. Properly trained Porsche technicians have the equipment, tools, safety instructions, and know-how to do the job properly and safely. Part numbers listed in these bulletins are for reference only. The work procedures updated electronically in the Porsche PIWIS diagnostic and testing device take precedence and, in the event of a discrepancy, the work procedures in the PIWIS Tester are the ones that must be followed.

© 2019 Porsche Cars North America, Inc.